

With drive engineering
formula bank

C-line DRIVES

Engineering Guide



The easy route
to your drive solution



Engineering Guide - c-line DRIVES

ID no.: 0927.25B.1-01 Sheets for Engineering Guide

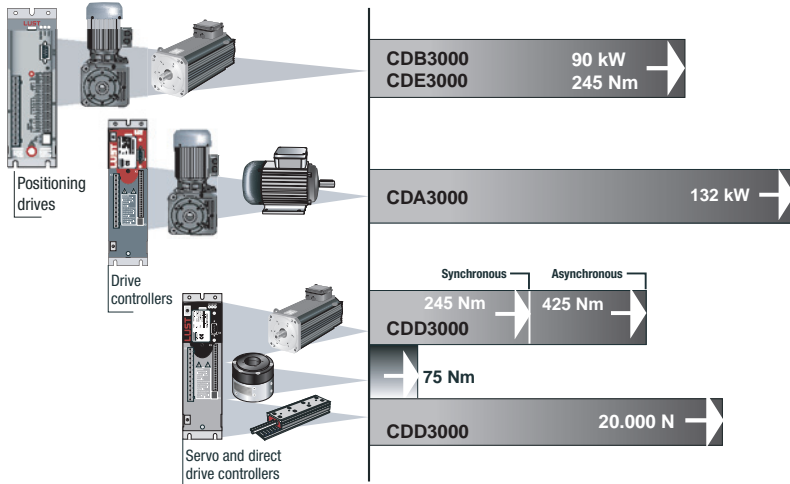
Date: 02/2007

We reserve the right to make technical changes.

c-line drive controllers

The c-line drive system comprises three controller series. They are:

- Positioning drive series CDE/CDB3000 for
 - asynchronous standard motors up to 90 kW
 - synchronous servomotors up to 245 Nm
- Drive controller series CDA3000 for
 - asynchronous standard motors up to 132 kW
 - special motors such as high-frequency or reluctance motors
- Servo and direct drive controller series CDD3000 for
 - asynchronous servomotors up to 425 Nm
 - synchronous servomotors up to 245 Nm
 - hollow shaft motor up to 75 Nm
 - linear motor up to 2000 N



This c-line DRIVES Engineering Guide does not cover the 24/48 V DC servocontroller CDF3000 or the HF drive controller CDS4000.

LUST

About this Guide

This Guide is intended for users looking for background information relating to the engineering of drive system projects.

The term "engineering" (or "project planning") in this context covers the design and configuration of complex technical systems through to receipt of the order to implement. Project engineering generally comprises the following elements:

- Analysis of the task
- Concept design of the system
- Design of the system components and
- Selection of the best solution to be implemented.

Rather than focussing on one aspect, this Engineering Guide covers a range of concepts. Not all the concepts covered will be new to you. What is new is the overall picture which emerges when all the various aspects are linked together, bringing new, fascinating drive solutions to supplement the existing, familiar ones. Try it.

Constructive feedback

We welcome your constructive feedback. Write to us if you have any suggestions for improvements, because, after all, "better is better than good". We will take your useful suggestions onboard and include them in the next issue of the Guide.

Please send your suggestions to:

Lust Antriebstechnik GmbH
Gewerbestraße 5-9
D-35633 Lahnau

For the attention of: Mr. Joachim Schäfer
e-mail: joachim.schaefer@lust-tec.de

How to use this Guide

1	Analysis of the task	1
2	Selecting motors, encoders and gearing	2
3	Selecting drive controllers	3
4	Selecting the additional components	4
5	Information on system design	5
6	Defining the drive	6
	Appendix: Practical guide, with formula bank, drive controllers, motors, gearing, protection and source references	A

Changes from version: 0927.05B.0-01 January 2006
 to version: 0927.05B.1-00 September 2006

The following pages are changed/corrected:

Chapter	Page(s)	Comment/Subject
UMS_VORN	2	Index counted up
UMS_HINT	2	
Table of contents	complete	Page numbers changed
Pre-chapter	System overview	2000 N changed to 20.000 N
Chapter 2		
		Replace chapter 2 completely
2.2.3	2-21	Note added
	2-25	Lifetime changed to bearing lifetime
	2-34	Chapter 2.2 changed to 2.1
	2-37 to 2-41	Text completely revised
2.6	2-97	t_1 and t_2 changed to $t_{2=}$ and t_1
Chapter 3		
		Replace chapter 3 completely
3.1	3-3	2000 N changed to 20.000 N
	3-6 to 3-10	Tables added
3.2.6	3-29	ATTENTION added
3.2.10	3-34	Voltage data changed
3.2.15	3-41	Figures in table changed
	3-43	1000 m changed to 100 m
3.2.22	3-52 to 3-53	Chapter added
3.3	3-54 to 3-96	Pages added
Chapter 4		
4.1.1	4-5	Formula changed
	4-6	Table added, text changed
4.2	4-13	Note added
4.5.2	4-26	Calculation added

Chapter	Page(s)	Comment/Subject
Chapter 6 6.2.3	6-7 to 6-16	Chapter added
Appendix A.2.9	A-28	Text and formulas corrected Bibliography and list of sources completed

1	Analysis of task	
1.1	Systematic thinking	1-2
1.1.1	Drive system	1-3
1.1.2	System environment	1-4
1.2	Process analysis	1-5
1.2.1	Example of a process analysis compared to functional analysis	1-5
1.3	Characteristic values of machinery	1-10
1.3.1	Movement requirement	1-10
1.3.2	Moment of inertia	1-13
1.3.3	Manipulating range and accuracy	1-14
1.3.4	Modern-day movement control	1-24
1.3.5	Load torque	1-29
1.4	Recording of movement task	1-33
2	Selecting motors, encoders and gearing	
2.1	General aspects of motor selection	2-2
2.1.1	Selecting a motor	2-6
2.2	Selecting standard three-phase AC motors	2-7
2.2.1	Characteristic values of standard three-phase AC motors	2-8
2.2.2	Characteristic values of asynchronous servomotors	2-18
2.2.3	Characteristic values of LSH servomotors	2-21
2.3	Selecting special three-phase AC motors	2-45
2.3.1	Characteristic values of reluctance motors	2-46
2.3.2	Characteristic values of synchronous motors with damper cage	2-50
2.3.3	Characteristic values of high-frequency motors	2-53
2.4	Selecting encoders	2-58
2.4.1	Overview of types	2-59
2.4.2	Encoder systems for c-line DRIVES	2-73
2.4.3	Project planning	2-77
2.4.4	Interfaces	2-80

2.5	Selecting gearing	2-83
2.5.1	Selecting standard gears	2-84
2.5.2	Selecting planetary gears	2-91
2.6	Selecting the motor brakes	2-94
3	Selecting drive controllers	
3.1	c-line drive controllers	3-3
3.1.1	Acceptance tests/Ambient conditions	3-5
3.1.2	Modular heat sink concept	3-11
3.2	Measures for your safety	3-13
3.2.1	Intended use	3-14
3.2.2	System condition	3-16
3.2.3	Operation in IT network	3-20
3.2.4	Loading on the supply system	3-23
3.2.5	General points on the power connections	3-24
3.2.6	cUL approbation	3-27
3.2.7	Operation on fault current breaker	3-31
3.2.8	Leakage currents	3-32
3.2.9	Switching at the mains input	3-34
3.2.10	High-voltage test/Insulation test	3-34
3.2.11	Forming of the DC-link capacitors	3-35
3.2.12	Direction of rotation and terminal designation	3-37
3.2.13	Switching at the drive controller output	3-38
3.2.14	Short-circuit and ground fault proofing	3-40
3.2.15	Motor cable length, current and voltage losses	3-41
3.2.16	Voltage load on the motor winding	3-44
3.2.17	Motor protection possibilities	3-45
3.2.18	Bearing stress in drive controller operation	3-46
3.2.19	Calculation of effective drive controller capacity utilization	3-47
3.2.20	Measurement on the drive controller	3-49
3.2.21	DC network operation (DC coupling)	3-51
3.2.22	Calculation of the continuous braking power of internal braking resistors	3-52

3.3	c-line field busses3-54
3.3.1	Overview on field busses3-54
3.3.2	CAN-basics3-55
3.3.3	CANopen profiles3-68
3.3.4	PROFIBUS-DP Basics3-83
3.3.5	Commissioning of drive controls on PRROFIBUS/S73-91
3.4	c-line drive controller system CDA30003-97
3.4.1	Current capacity of drive controllers CDA3000 ...3-97
3.4.2	Project planning for three-phase AC motors3-100
3.4.3	Efficiency of the motor control methods of the CDA30003-103
3.4.4	Standard drive controller operation3-108
3.4.5	70 Hz characteristic with 25 % field weakening3-110
3.4.6	87 Hz characteristic / Expanded manipulating range3-114
3.4.7	Multi-motor operation on one drive controller ...3-117
3.4.8	Encoder selection for FOR mode with CDA30003-120
3.4.9	Programming examples for applications with CDA3000-PLC3-126
3.4.10	Low motor losses based on CDA3000 with high- frequency PWM3-143
3.5	c-line positioning drive CDE/CDB30003-145
3.5.1	Current capacity of positioning drives CDE/CDB30003-145
3.6	c-line servo and direct drive controllers CDD30003-149
3.6.1	Current capacity of servo and direct drive controllers3-149
4	Selecting the additional components
4.1	Selecting the line choke4-2
4.1.1	Benefits of a three-phase line choke4-4
4.1.2	Line choke to conform to EN 61000-3-24-7

4.2	Selecting the braking resistors	4-8
4.3	Selecting the mains filters	4-14
4.3.1	Permissible motor cable length with internal RFI filter	4-14
4.3.2	Permissible motor cable length with external RFI filter	4-16
4.4	Selecting the motor choke	4-19
4.4.1	Technical data	4-19
4.4.2	Advanced project planning rule	4-20
4.5	Selecting the motor filters	4-22
4.5.1	Technical data	4-22
4.5.2	Advanced project planing	4-24
5	Information on system design	
5.1	Heat discharge from the switch cabinet	5-3
5.1.1	Basic terms for calculation	5-3
5.1.2	Effective cabinet surface	5-5
5.1.3	Calculation of filter fans	5-7
5.1.4	Calculation of heat exchangers	5-8
5.2	Heat transfer by conduction	5-9
5.2.1	Calculation example with CDA34.014, C (Cold Plate)	5-11
5.3	System feedback of power drives	5-16
5.3.1	Reducing system feedback	5-20
5.4	Reactive current compensation systems in electric power systems with non-linear loads	5-22
5.4.1	Resonance frequency in electric power systems	5-24
5.5	Electromagnetic compatibility (EMC) and power drives	5-26
5.5.1	EMC standardization of power drives	5-27
5.5.2	Limit curve for power drives (PDS's)	5-34

5.5.3	Typical measurement set-up for acceptance testing of power drives	5-35
5.5.4	Installation guidelines for switch cabinets	5-41
5.5.5	Sixteen EMC measures to DIN VDE 0100 part 440	5-43
5.6	Safety engineering for machines with power drives	5-45
5.6.1	Guidelines and EN norm group	5-48
5.6.2	Risk assessment and reduction	5-50
5.6.3	"Safe Standstill" to EN 954-1 category 3	5-52
5.6.4	Safety functions for movement control	5-63
5.6.5	Application of future EN ISO 13849-1 (EN 954-1) and EN IEC 62061	5-67
5.7	Drive controller fed power drives in areas subject to explosion hazards	5-76
5.7.1	Motors of protection category "d"	5-77
5.7.2	Protection measures	5-79
5.8	Fault current monitoring in electrical installations with power drive systems	5-82
5.8.1	Basic measurement method for RCMs/RCDs (type A)	5-84
5.8.2	All-current sensitive fault current breaker monitoring (RCM, type B) in earthed systems	5-84
5.8.3	All-current sensitive residual current monitoring in passenger and goods lifts	5-87
6	Drive definition	
6.1	Drive definition via power rating	6-2
6.1.1	Traction drive	6-3
6.1.2	Lifting drive	6-5

A	Practical Guide	
A.1	Mathematical symbols.....	A-3
A.1.1	SI units	A-3
A.1.2	Important units	A-5
A.2	Drive engineering equations.....	A-6
A.2.1	Basic physical equations.....	A-6
A.2.2	Power	A-7
A.2.3	Torques	A-12
A.2.4	Work.....	A-13
A.2.5	Friction	A-15
A.2.6	Effective motor torque/power output.....	A-16
A.2.7	Choice of max. acceleration	A-19
A.2.8	Mass moments of inertia	A-22
A.2.9	Optimum transmission ratio	A-28
A.2.10	v/t diagram	A-29
A.2.11	Efficiencies, coefficients of friction and density ..	A-32
A.2.12	Definitions of lateral forces	A-36
A.2.13	Autotransformer.....	A-37
A.2.14	Line choke.....	A-38
A.3	Drive controller.....	A-39
A.3.1	Voltage Frequency Control (VFC)	A-39
A.3.2	Basic principle of Sensorless Flux Control (SFC) .	A-44
A.3.3	Torque formation of synchronous and asynchronous motors.....	A-45
A.3.4	Basics of closed-loop control	A-48
A.3.5	Basic principle of torque, speed and position control	A-58
A.3.6	DC network operation	A-63
A.4	Motors	A-67
A.4.1	Thermal classes of electric motors.....	A-67
A.4.2	Colour coding of a threshold value PTC to DIN 44081	A-69
A.4.3	Linear PTC KTY-130-gel	A-72
A.4.4	Motor protection possibilities	A-73
A.4.5	Typical data of standard three-phase AC motors	A-74
A.4.6	Typical data of asynchronous servomotors.....	A-77

A.4.7	Overview of data of synchronous servomotors (LSH)	A-79
A.4.8	Typical data of EUSAS system motors	A-80
A.4.9	Typical data of slim-line three-phase AC motors made of extruded aluminium section	A-85
A.4.10	New connection markings for rotating electrical machines.....	A-87
A.5	Protection	A-91
A.5.1	Protection/IP code to IEC/EN	A-91
A.5.2	Protection to EEMAC and Nema	A-98
A.5.3	Cable glands with PG/metric thread.....	A-100
A.5.4	Outer diameters of wires and cables	A-101
A.5.5	Current capacity of PVC-insulated copper wires.....	A-103
A.5.6	Colour coding for pushbuttons/controls	A-105
A.5.7	Colours of indicator lights	A-106
A.5.8	Standardized Transverse section of round conductors (ISO/AWG).....	A-107

B Practical working aids for the project engineer

C Bibliography and source references

D Index

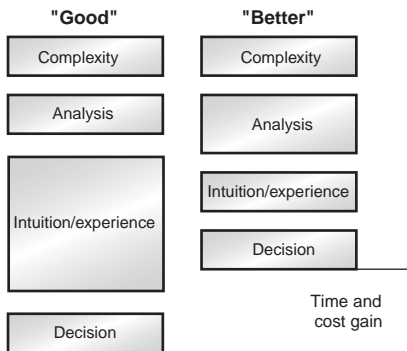


1 Analysis of task

- 1.1 Systematic thinking1-2**
 - 1.1.1 Drive system 1-3
 - 1.1.2 System environment 1-4
- 1.2 Process analysis1-5**
 - 1.2.1 Example of a process analysis compared to functional analysis 1-5
- 1.3 Characteristic values of machinery1-10**
 - 1.3.1 Movement requirement 1-10
 - 1.3.2 Moment of inertia 1-13
 - 1.3.3 Manipulating range and accuracy 1-14
 - 1.3.4 Modern-day movement control 1-24
 - 1.3.5 Load torque 1-29
- 1.4 Recording of movement task1-33**

Take your time, especially at the beginning!

Please note: The more complex the task, the more important is the analysis. A "better" analysis can identify impending failures in good time.



1.1 Systematic thinking

*Thinking differently
[leads to]
Belief
[in turn resulting in]
Acting differently.*

Before beginning your project planning you should read through this section - it will help you identify how to attain the new solutions you need.

What can we learn from system analysis? The term "system" in this context means:

- A unified whole, distinct from its surroundings.
- comprising individual elements
- between which fixed relationships exist
- and which perform specific functions.

The starting point for any system analysis is to record, understand and order the existing inter-relationships within a system. To this end, the system is split down into its subsidiary areas (components) such that all the individual components are distinct from each other and the relations between them become visible.

1.1.1 Drive system

The chain is only as strong as its weakest link.

A drive system comprises the following individual components and modules:

- Power module
- Operator module
- User module
- Communication module
- Software modules
- Line choke
- Mains filter
- Motor choke
- Braking resistor
- Cable
- Motors
- Gearing
- etc.

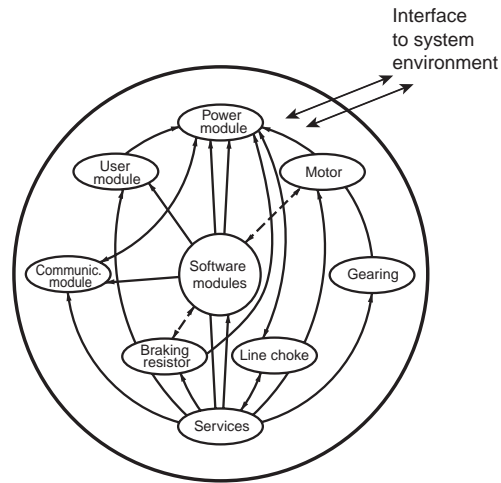


Figure 1.1 Drive system

In summary

A drive system is a combination of standalone products and services which create new usable drive system properties with added value.

1.1.2 System environment

Analysis of the system environment of drive systems reveals four interfaces which outline that environment:

1. Interface to the processing process
2. Interface to the automation process
3. Interface to the surrounding environment and installation conditions
4. Interface to the requirements arising from standards, regulations and safety concerns

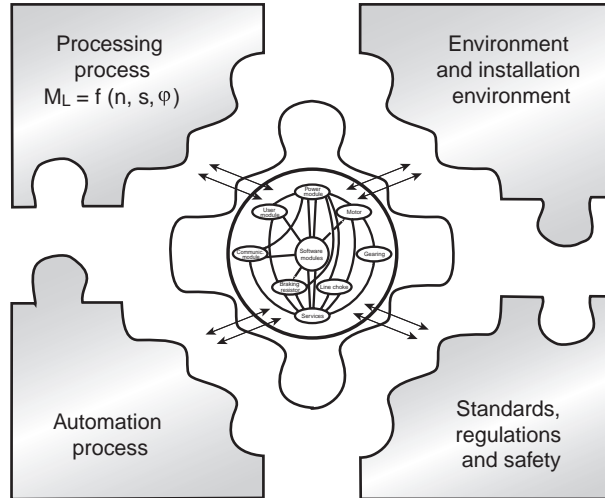


Figure 1.2 System environment

This section deals with the interface to the "processing process". The other interfaces are dealt with in the subsequent sections of the Guide.

1.2 Process analysis

First find out what processing process the drive solution is to be used for.¹ Apply the principles of process analysis, because process analysis will provide you with a non-solution-specific view of the task at hand.

Do not perform a functional analysis at the beginning of an analysis, because the functions used always describe the specific solution.

If you want to find a new solution you should carry out a process analysis.



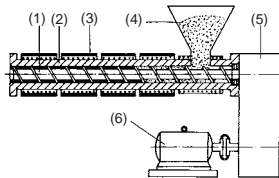
The functional analysis is derived from the² value analysis. Its main role is to eliminate dual functions and to cut the cost per function.

1.2.1 Example of a process analysis compared to functional analysis

Standard worm extruder

- An extruder is a machine which takes in solid to liquid (synthetic) moulding compounds and presses them out of an opening, for the most part continuously. It compresses, mixes, plasticizes and homogenizes the compound in the process.

The screw-type extruder shown (see Figure 1.3) principally comprises a drive unit and a plasticizer unit. The plasticizer unit consists of a screw cylinder, a screw, a material funnel, and heating and cooling zones.



- | | |
|--------------|-------------|
| (1) Worm | (4) Funnel |
| (2) Cylinder | (5) Gearing |
| (3) Heater | (6) Motor |

Figure 1.3 Schematic of an extruder

1. Processing process: A process during which energy, information and/or material is reformed and transported.
2. The value analysis method was developed in 1948 by the Purchasing department of the General Electric corporation. Literature: DIN 69910 and VDI 2801.

The drive unit is formed by a regulated DC drive, gearing and the screw return thrust bearing, which absorbs the forces occurring during conveying and plasticizing.

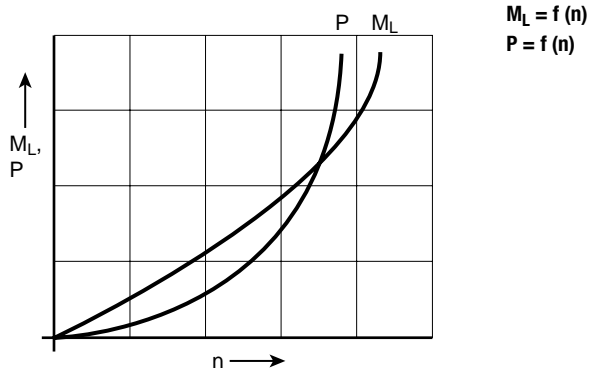
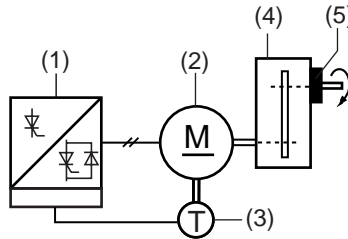


Figure 1.4 Load characteristic of the plastics extruder

Task for a new drive unit

In order to provide a higher degree of machine availability, the drive is to be switched from DC to three-phase AC. The DC drive used to date has a speed manipulating range of 1:1000 and an overload capacity to 200 %.



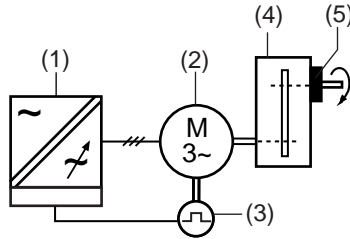
- (1) DC controller
- (2) DC motor
- (3) Tacho
- (4) Gearing
- (5) Screw return thrust bearing

Figure 1.5 Old solution with DC drive

Functional analysis

In a functional analysis each component which performs a function must merely be replaced by another one. In this case this means:

- the DC motor is replaced by an AC motor
- the tacho is replaced by an encoder and
- the DC controller is replaced by a drive controller with field-oriented regulation.



- (1) Drive controller with field-oriented regulation
- (2) AC motor
- (3) Encoder
- (4) Gearing
- (5) Screw return thrust bearing

Figure 1.6 Solution from functional analysis

The functional analysis produces a solution with speed feedback, see Table 1.1.

DC drive	Three-phase AC drive
1 DC controller	1 Drive controller with field-oriented regulation
2 DC motor	2 AC motor
3 Tacho	3 Encoder
4 Gearing	4 Gearing
5 Screw return thrust bearing	5 Screw return thrust bearing
Old solution	Functional analysis (NEW 1)

Table 1.1 Comparison between old solution and solution from functional analysis

Process analysis

A process analysis establishes what demands the processing process places on the drive.

Questions to be answered:

1. What is the movement requirement for processing?
2. What is the moment of inertia of the processing machine, referred to the motor shaft?
3. What manipulating range is required for the processing process?
4. What load torque needs to be overcome?

Answers to the questions in this example:

1. Continuous material flow.
2. Is of no significance in applications with continuous material flow.
3. Speed manipulating range of 1:10.
4. No overload necessary, because the screw of the extruder would otherwise be damaged. When the screw has become clogged, it is drawn forward out of the extruder for cleaning.

The answers supplied in the process analysis deliver a solution with a standard drive controller without speed feedback. This means a substantial cost reduction.

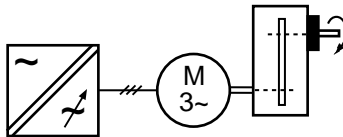


Figure 1.7 Solution from process analysis

Comparison of solutions: Functional analysis/Process analysis

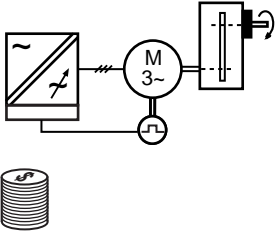
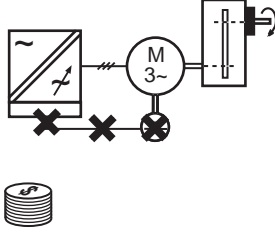
Solution from functional analysis	Solution from process analysis
	
<p style="text-align: center;">NEW 1 Drive controller with field-oriented regulation</p>	<p style="text-align: center;">NEW 2 Drive controller VF control</p>

Figure 1.8 Comparison of solutions

In summary

Always analyze the processing process!

Because just because something is *known* does not necessarily mean it is *recognized*!

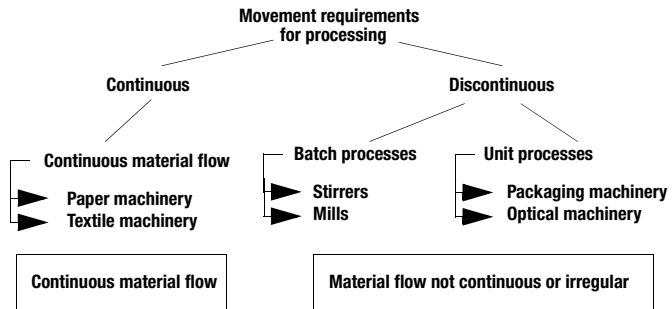
1.3 Characteristic values of machinery

You do not usually need to take account of the detailed structure of the machinery for drive project planning. It can be adequately described by:

1. the movement requirement for processing
2. the moment of inertia of the processing machine, referred to the motor shaft
3. the manipulating range and accuracy of the torque, speed and position
4. the characteristic over time of the load torque

1.3.1 Movement requirement

The movement requirement for processing is roughly divided into three groups.



Traction and mechanical function

The movement solution in the processing process in most cases involves a traction function and a mechanical function. The mechanical function usually generates a non-linear movement. The processing process counteracts this movement with a specific load torque.

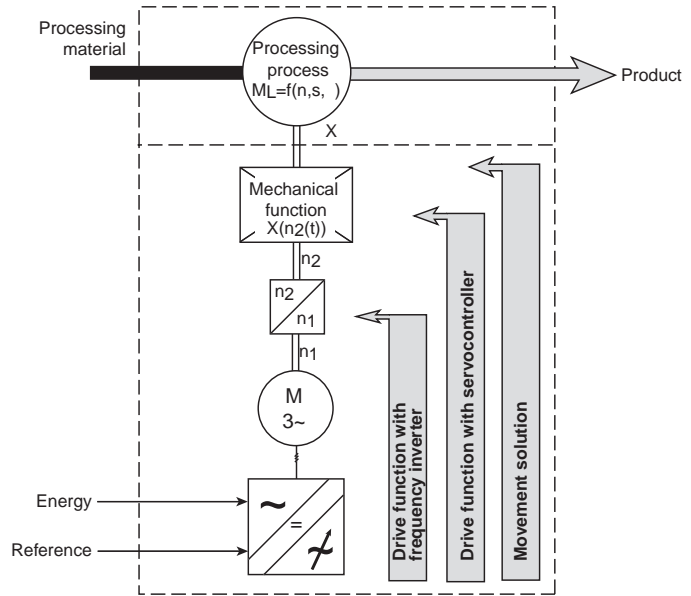


Figure 1.9 Movement solution in the processing process



Solutions for mechanical functions (movement tasks) with gearing are set out in the design catalogues of VDI 2727. Electronically coordinated movements with a positioning drive and servocontroller with cam plate function are more and more widely replacing the conventional synchronous mechanical functions. The law of movement for cam plates is set out in VDI 2143.

Example of a movement solution

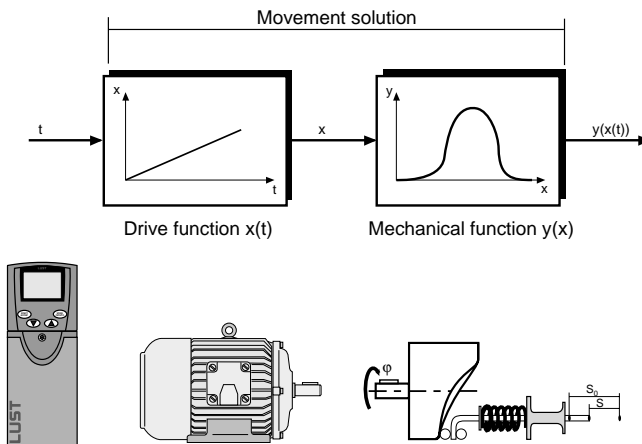


Figure 1.10 Movement solution split into traction and mechanical function

v/t diagram

The processing cycle of a machine or plant is typically described by the velocity/time profile, also termed the v/t diagram. From that diagram the acceleration/deceleration time and the startup and shutdown frequency can be determined. This repetition rate of the startup and shutdown process determines the

- motor rating

$$M_{\text{eff}} = \sqrt{\frac{M_1^2 \cdot t_1 + M_2^2 \cdot t_2 + M_n^2 \cdot t_n}{T}}$$

- the current load of the drive controller

$$I_{\text{eff}} = \sqrt{\frac{I_1^2 \cdot t_1 + I_2^2 \cdot t_2 + I_n^2 \cdot t_n}{T}}$$

- and the braking chopper design

$$P_D = \frac{\text{On-time [s]}}{\text{Cycle time [s]}} \cdot \text{Peak braking power [w]}$$



For more information on the subject of the v/t diagram and on calculating effective values refer to the formula bank in the Appendix.

1.3.2 Moment of inertia

The moment of inertia of a machine or a machining process is kept as low as possible. However, the room for manoeuvre in terms of dimensioning is very low as a result of the pressure for technological optimization.

The moment of inertia of motors is of great significance for the overall drive design in cases of frequent and rapid changes of speed, while in rotational drives, such as a sugar centrifuge or a continuous winding drive, a reduction in the moment of inertia of the motor has little or no effect on the overall drive design.



For more information on this subject refer to the formula bank in section A.2.8 and section 2.

1

2

3

4

5

6

A

1.3.3 Manipulating range and accuracy

The desired torque rise time, the speed manipulating range and the positioning accuracy are likewise determined by the technological processing process.

In the following some terms are defined more closely, in order to avoid misunderstandings between you - the customer - and us - the drive manufacturer.

Torque

General movement equation:

$$J \frac{d\omega}{dt} = m_a - m_L$$

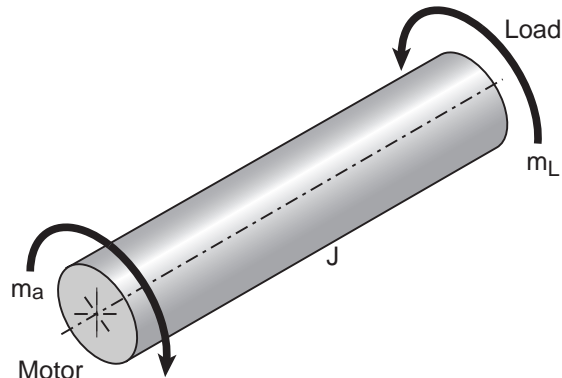


Figure 1.11 Torque

- The difference between the drive and load torque accelerates the moment of inertia J at $\frac{d\omega}{dt}$
- From standstill:
 - $m_a > m_L$ \Rightarrow Clockwise
 - $m_a < m_L$ \Rightarrow Anti-clockwise
 - $m_a = m_L$ \Rightarrow Standstill
- If $m_a > m_L$, the drive accelerates until $m_a = m_L$. The maximum attainable velocity is limited by
 - the voltage limit of the drive controller, i.e. at high speeds the voltage to generate the drive torque and
 - the load torque rising with the speed (e.g. friction) is missing.

Accuracy of a torque control with an asynchronous machine

The torque of the asynchronous machine is dependent on a number of machine parameters which are in turn temperature-dependent. The stationary relative accuracy of the torque control is thus approximately $\pm 10\%$. The torque drifts as a result of temperature fluctuations by about $\pm 1\%$ rel.

Accuracy of a torque control with a synchronous machine

The torque of the synchronous machine is dependent only on constant machine parameters, apart from torque-forming current. The stationary relative accuracy is approximately $\pm 2\%$. The torque does not drift.

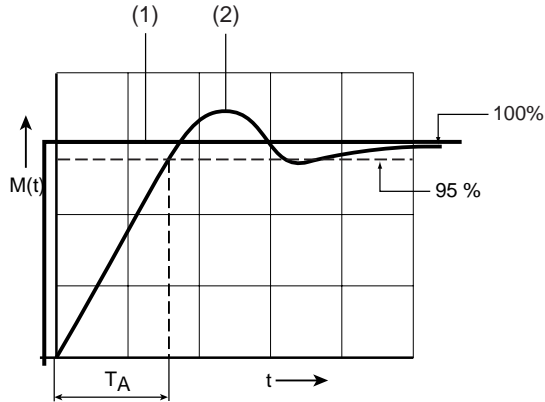


With analog torque input the drift of the analog reference input must additionally be allowed for.

Torque rise time

The torque rise time is the time which elapses after a reference step from 0 to M_N until the actual value of the torque in the motor has reached 95 % of the nominal value.

The torque rise time is dependent on the control methods applied and on the electrical parameters of the motor used. As the speed increases the voltage reserve for injection of a current falls, causing the torque rise time to increase.



T_A = Torque rise time

(1) Reference (2) Actual

Figure 1.12 Torque rise time

Speed manipulating range

The speed manipulating range is the speed range in which the motor can always deliver nominal torque.

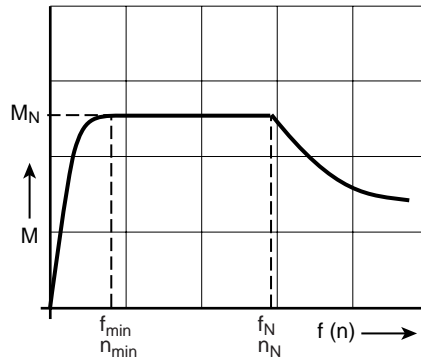


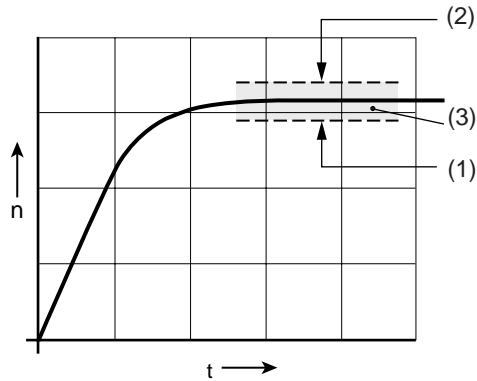
Figure 1.13 Speed manipulating range

$$\text{Manipulating range} = \frac{f_N}{f_{min}} = \frac{n_N}{n_{min}}$$

- f_N Rated frequency in Hz
- f_{min} Minimum frequency in Hz
- n_N Rated speed in rpm
- n_{min} Minimum speed in rpm

Stationary speed accuracy

The stationary speed accuracy refers to the speed deviation in the steady (static) state after completion of startup.



- (1) Lower limit
- (2) Upper limit
- (3) Variation range

Figure 1.14 Static speed accuracy

In operation with speed control (with encoder feedback) a high-frequency ripple is superimposed on the motor speed. The frequency of the ripple depends on the sampling rate of the speed controller. The amplitude of the said ripple is dependent on the encoder system used and on the mass inertia system (application and motor). Typical values are collated in the following table.

Encoder	Con-troller	Period/UPM Encoder	Period/UPM Interpolation in controller	Measuring accuracy of position in controller	Typical measuring accuracy of encoder systems	Accuracy of speed control (16-bit resolution)	Typical Amplitude of the high-frequency speed accuracy
Resolver	CDD/CDE	1	16000	+/- 1'	+/- 20'	Stationary/Quartz-accurate ¹⁾	+/- 20 min ⁻¹ ²⁾
Resolver	CDD/CDE	3	49152	+/- 0.3'	+/- 10'	Stationary/Quartz-accurate ¹⁾	+/- 10 min ⁻¹ ²⁾
sin/cos encoder	CDD	2048	33 mil.	+/- 0.5"	+/- 20"	Stationary/Quartz-accurate ¹⁾	+/- 2 min ⁻¹ ²⁾
HTL encoder	CDA	2048	8192	+/- 2.5'	+/- 2.5'	Stationary/Quartz-accurate ¹⁾	+/- 20 min ⁻¹ ²⁾
HTL/TTL	CDB	2048	8192	+/- 2.5'	+/- 2.5'	Stationary/Quartz-accurate ¹⁾	+/- 20 min ⁻¹ ²⁾

- 1) If two c-line DRIVES are assigned the same digital speed reference, their axes drift apart like the seconds pointers of two quartz clocks (approx. 1 °/h). This response is independent of the encoder system.
- 2) The actual speed has a high-frequency speed ripple, corresponding to the sampling rate of the speed control (CDD/8kHz, CDA/4kHz). The amplitude of the ripple depends on the encoder type used, the mass moment of inertia and the P-component of the encoder.

NOTE: The age is divided into minutes (1° = 60') and seconds (1' = 60").

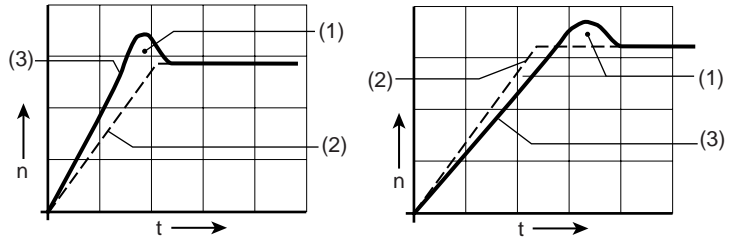
Table 1.2 Typical accuracy of speed control depending on the encoder systems

For more information on the subject of accuracy refer to section 2.4.



Dynamic speed accuracy

The dynamic speed accuracy refers to the speed deviation during the startup or braking process of a speed change. The greatest deviation very often occurs in the transient response in settling to the desired speed.



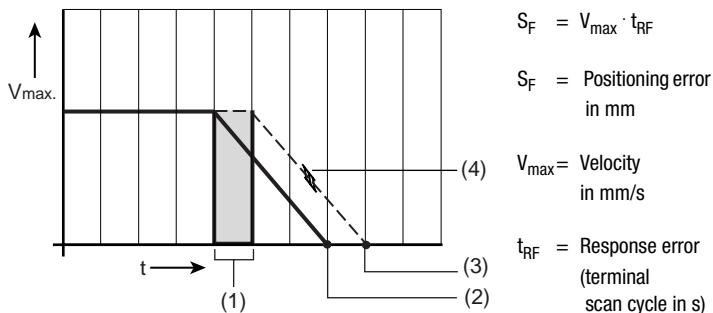
- (1) Dynamic variation
- (2) Reference
- (3) Actual

- (1) Dynamic variation
- (2) Reference
- (3) Actual

Figure 1.15 Dynamic speed accuracy

Positioning accuracy without position control (Start/Stop mode)

The term positioning accuracy refers to the position deviation at standstill. The degree of variation is decisively influenced by the response times of the control and the drive controller.



- (1) Scan cycle of control terminals on drive controller (t_{RF} = response error)
- (2) Target position 1 (stop signal comes together with read-in of control signals on drive controller)
- (3) Target position 2 (stop signal comes directly after read-in of control signals on drive controller)
- (4) Slip range (depending on control mode the braking ramp is slip-dependent)

Figure 1.16 Start/Stop positioning

The positioning and repeat accuracy is of course also dependent on other factors such as:

- Implementation of the mechanical function
- Mechanical system of the pickup
- Gearing used
- Constant response time of the control
- Measurement resolution from position encoder etc.

A precise analysis is only possible in specific cases.

Positioning accuracy with position control in control

In the case of a positioning operation with position control in the control, the positioning accuracy is dependent on the encoder system and the quality of the position control.

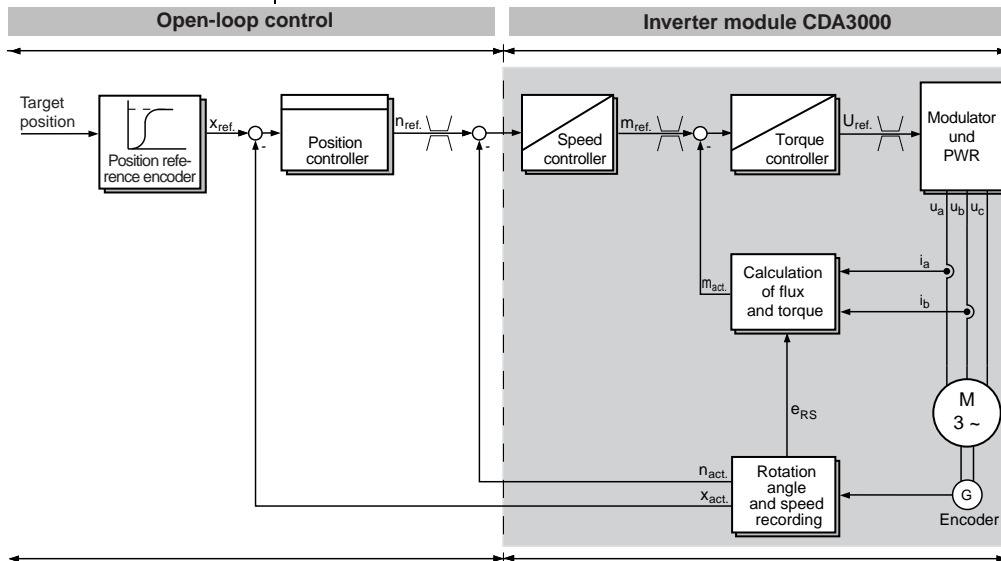


Figure 1.17 Positioning with reference generator and position control in the control

Position reference generator

The reference generator generates the characteristic over time of the reference position.

Position controller

The position controller ensures that the reference position is maintained as closely as possible.

Speed controller

The speed controller in turn ensures that the reference speed of the motor is maintained.

- The speed reference can be specified via +10 V to -10 V or via CAN or PROFIBUS.

Positioning accuracy with position control in the drive controller/servocontroller

When positioning with a positioning drive too, the positioning accuracy depends on the encoder system and the quality of the position control.

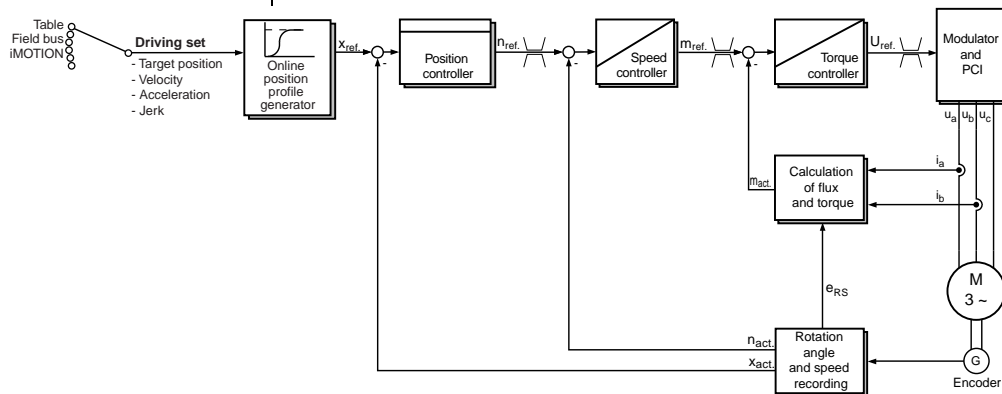


Figure 1.18 Basic principle of position control in the c-line drive controller

Typical accuracy of position control depending on the encoder system

Measuring system	Period/UPM Encoder	Incr. per rev.	Positioning accuracy absolute/repeat
Resolver	3	4900	$\pm 10'$
sin-cos encoder	2048	33 mil.	$\pm 20''$
HTL/TTL encoder	1024	4096	$\pm 5'$
HTL encoder	2048	8192	$\pm 2.5'$

NOTE: The age is divided into minutes ($1^\circ = 60'$) and seconds ($1' = 60''$).

Table 1.3 Typical accuracy of position control depending on the encoder system

In summary

The positioning accuracy is dependent on the measurement system and on the position control sampling. It is also of course dependent on the sources of error of the machine (temperature, rigidity, vibration, etc.).

1.3.4 Modern-day movement control

The term 'movement control' refers to the coordination of machine elements spatially and over time. Depending on the movement task at hand, specific types of movement function have emerged.

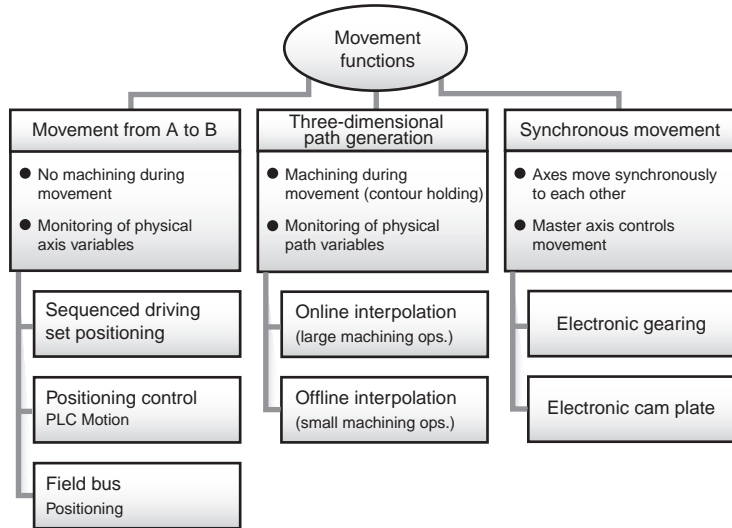


Figure 1.19 Task-oriented systemization of movement functions

Movement from A to B

Positioning is the movement of a machine element from position A to B. During positioning no machining is possible. At the start and end of positioning the velocity is zero. The "positioning" movement function relates to a single axis.

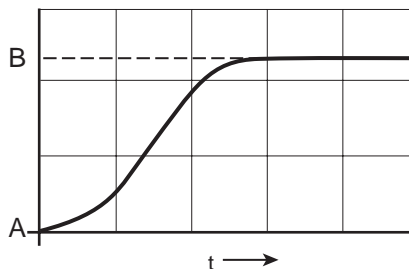


Figure 1.20 Positioning from A to B

Sequenced driving set positioning

Sequenced driving set positioning is characterized in that various positions are approached in a pre-determined order. The various positioning jobs with follow-up logic are saved in driving sets. Various positioning modes, such as absolute, relative, infinite (velocity-controlled) and path-optimized indexing table positioning can be selected.

PLC Motion

PLC Motion handles process-oriented additional tasks and coordinates positioning. The process is not parameterized, but programmed. For other performance capabilities refer to the relevant product documentation.

Field bus positioning

Positioning via field bus is characterized in that the target position, velocity, acceleration and jerk are set over the field bus (CAN, PROFIBUS).

1

2

3

4

5

6

A

Three-dimensional path generation

Online interpolation for large-scale machining operations

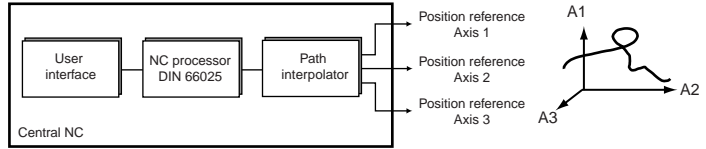


Figure 1.21 Conventional NC functionality for machine tools

- Online path interpolation not decentralizable
- Mathematical methods of path interpolation and NC processor very costly

Offline interpolation for small-scale machining operations

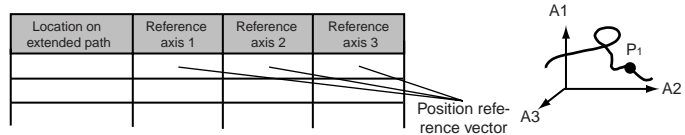


Figure 1.22 Offline calculation of position reference vectors to describe the path

- Table columns (location on path and reference for each) stored in the axis controllers
- Movement of a virtual axis in central unit and cyclic transfer of the current location on the path over the bus system
- Arithmetic allocation of the current reference position on the axes
- Advantages: Low online computing power, low online bus load

Synchronous movement

A slave movement is derived from a master movement in real-time according to a specific law of movement. Synchronous movements involve at least two axes:

- one master axis (real or virtual axis)
- one or more slave axes.

Electronic gearing

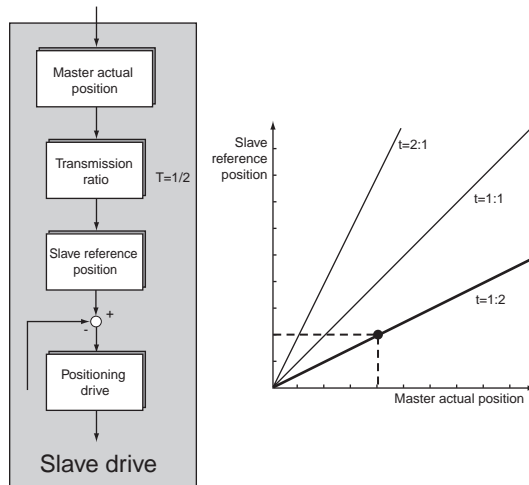


Figure 1.23 Reference position of slave drive is linear function of position of master drive

With electronic gearing, the motor (master) and slave movements are coupled via the angle at a transmission ratio. If load changes cause variations in the angle on the slave axis, they are detected and adjusted.

Electronic cam plate

With an electronic cam plate the master value serves as the input variable for a cam function. The function delivers the actual position reference for the slave axis.

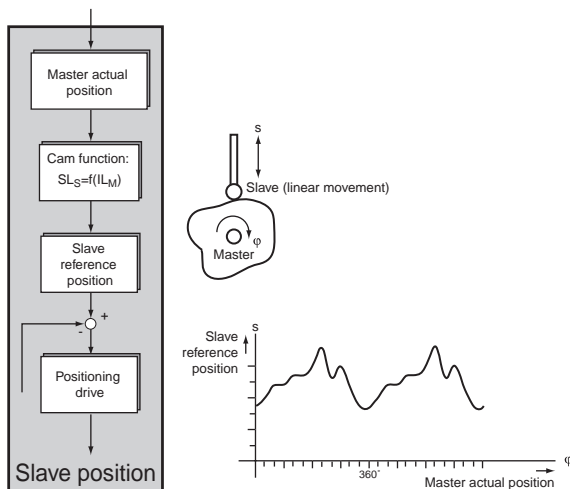


Figure 1.24 Position of slave drive is non-linear function of position of master drive

Electronic cam plates are typically stored in drive controllers in the form of tables. The tables contain value pairs comprising the master value and associated slave value. Each value pair forms an interpolation point of the cam plate. The value pairs were generally calculated externally and then stored in the drive controller.

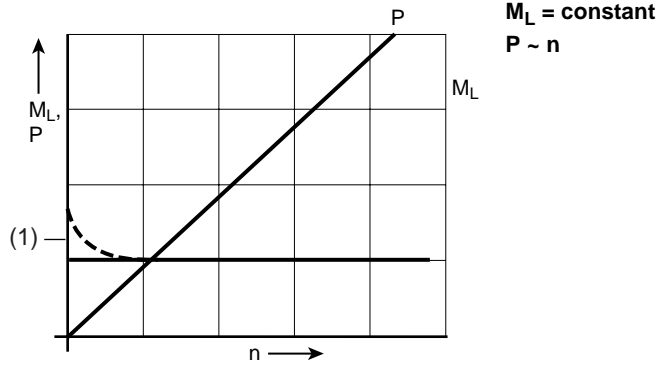


Limits of mechanical cam plates

- The velocity of mechanical cam plates is limited, as tappets tend to lift.
- Not all path movements are achievable; the tappet and lever may stick.
- Pressure on the lever often causes oscillations.
- Engaging and disengaging functions are difficult.
- Mechanical cam plates are expensive.
- Modifications to the cam plates (format changes) are very complex.

1.3.5 Load torque

Lifting gear, conveyor systems, piston compressors, rolling mills



(1) Break-away torque

Figure 1.25 Load characteristic: Lifting gear, conveyor systems, piston compressors, rolling mills

Extruder

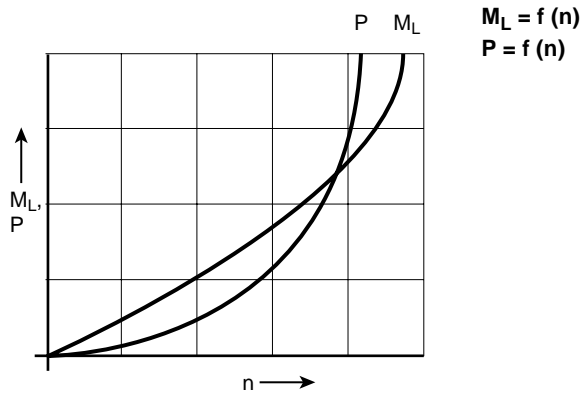


Figure 1.26 Load characteristic: Extruders

Blowers, fans, centrifugal pumps

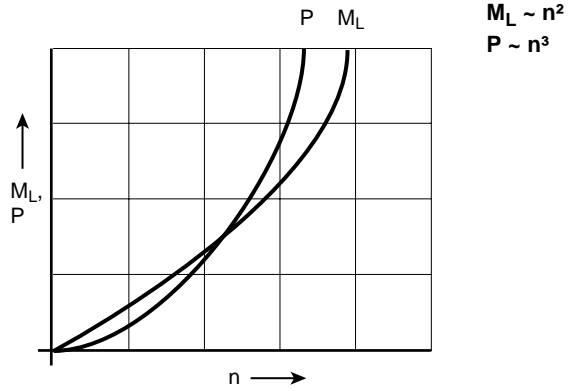
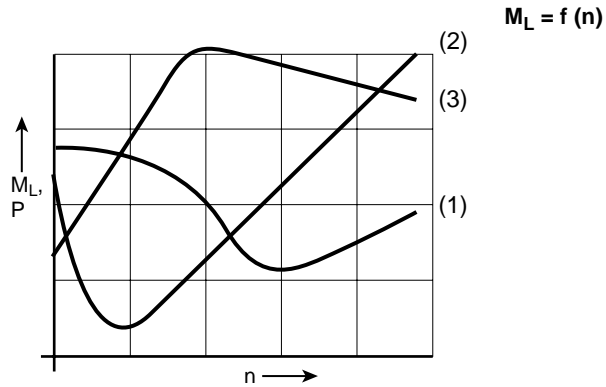


Figure 1.27 Load characteristic: Blowers, fans, centrifugal pumps

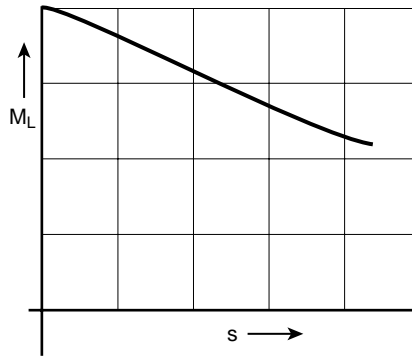
Mills



- (1) Hammer mill
- (2) Centrifugal mill
- (3) Ball mill

Figure 1.28 Load characteristics: Mills

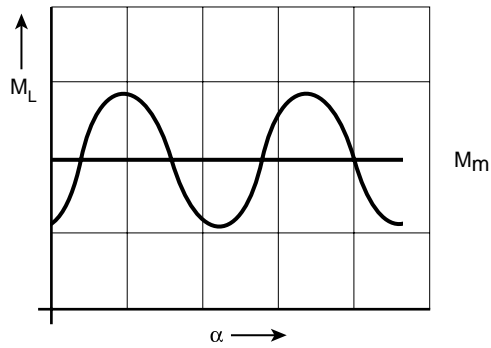
Conveyors such as inclined lifts



$$M_L = f(s)$$

Figure 1.29 Load characteristic: Conveyors

Piston machines, eccentric presses, metal cutters



$$M_L = f(\alpha)$$

Figure 1.30 Load characteristic: Piston machines, eccentric presses, metal cutters

Machine tools

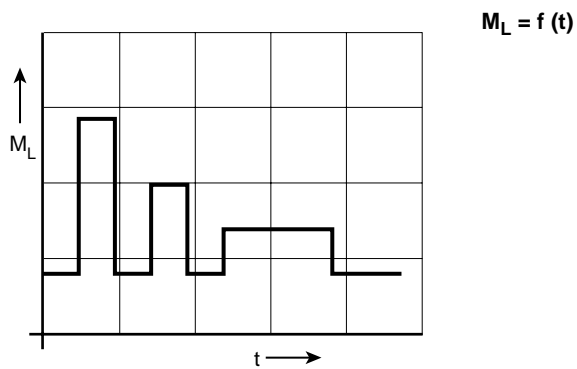


Figure 1.31 Load characteristic: Machine tools

Movement requirement

Movement requirements for processing	Project name: _____
<div style="display: flex; justify-content: space-around; margin-bottom: 10px;"> <input type="checkbox"/> Continuous material flow <input type="checkbox"/> Discontinuous batch process <input checked="" type="checkbox"/> Discontinuous batch process </div> <div style="text-align: center; margin-bottom: 10px;"> </div> <div style="display: flex; justify-content: space-around; margin-bottom: 10px;"> <input type="checkbox"/> Rotational movement [n=f(t)] <input checked="" type="checkbox"/> Translational movement [v=f(t)] </div> <p>Radius of drive shaft via which movement is generated <u>65</u> mm</p> <p>Comments: <u>A positioning accuracy of 0.5 mm is to be attained.</u> <u>For time reasons no slow jog mode must be run.</u></p> <p>Author: _____ Date: _____ Page <u>2</u> of <u>4</u></p>	

For definitions of terms in this context see see Chapter 1.3.

You will find the "Practical working aids for the project engineer" template in the Appendix.

Movement requirement

Movement requirements for processing	Project name: _____
Moment of inertia: _____ [kgm ²] or Mass: <u>200</u> [kg]	Movement type: <u>Translational</u> (conveyor belt) - see section 7.2.9
Speed manipulating range: _____	Torque rise time: _____ [ms]
Static speed accuracy: _____ [rpm]	Positioning accuracy: <u>± 0.5</u> [ms]
Dynamic speed accuracy: _____ [rpm]	_____ : _____ []
Comments: <u>Transmission, see drawing in Appendix</u>	
<p>Load torque of processing process</p> <input type="checkbox"/> $M_L \sim 1/n, P = \text{constant}$ <input checked="" type="checkbox"/> $M_L = \text{constant}, P \sim n$ <input type="checkbox"/> $M_L = f(n), P = f(n)$ <input type="checkbox"/> $M_L \sim n^2, P \sim n^3$ <input type="checkbox"/> $M_L = f(n)$ <input type="checkbox"/> $M_L = f(s)$ <input type="checkbox"/> $M_L = f(\alpha)$ <input type="checkbox"/> $M_L = f(t)$	
Author: _____	Date: _____ Page <u>3</u> of <u>4</u>

For definitions of terms in this context see section 1.3.

You will find the "Practical working aids for the project engineer" template in the Appendix.

System interface

- Automate
- Environment
- Standards

Further data from the environment	Project name: _____
<p>Automation process: <u>Coupling to Simatic S7 via Profibus-DP</u> <u>with protocol to EN50170</u> _____ _____</p> <p>Environment and installation environment: <u>Cabinet installation, but ambient</u> <u>temperature of 50 °C</u> _____ _____</p> <p>Standards, regulations and safety: <u>CE, EMC otherwise no further standard/</u> <u>regulations</u> _____ _____</p> <p>Author: _____ Date: _____ Page <u>4</u> of <u>4</u></p>	

You will find the "Practical working aids for the project engineer" template in the Appendix.

2 Selecting motors, encoders and gearing

2.1	General aspects of motor selection	2-2
2.1.1	Selecting a motor	2-6
2.2	Selecting standard three-phase AC motors	2-7
2.2.1	Characteristic values of standard three-phase AC motors	2-8
2.2.2	Characteristic values of asynchronous servomotors	2-18
2.2.3	Characteristic values of LSH servomotors	2-21
2.3	Selecting special three-phase AC motors	2-45
2.3.1	Characteristic values of reluctance motors	2-46
2.3.2	Characteristic values of synchronous motors with damper cage	2-50
2.3.3	Characteristic values of high-frequency motors ..	2-53
2.4	Selecting encoders	2-58
2.4.1	Overview of types	2-59
2.4.2	Encoder systems for c-line DRIVES	2-73
2.4.3	Project planning	2-77
2.4.4	Interfaces	2-80
2.5	Selecting gearing	2-83
2.5.1	Selecting standard gears	2-84
2.5.2	Selecting planetary gears	2-91
2.5.3	Selecting the motor brakes	2-94

2.1 General aspects of motor selection

The data on the rating plate of a motor relates to operation mode S1. The rating plate is classified as a document. Non-conformance to operation mode S1 must be indicated on the rating plate.

The key items of data on the rating plate are:

Rated voltage	U_n
Rated current	I_N
Rated power output	P_N
Rated speed	n_N
Rated torque (commonly only for servomotors)	M_N
Power factor	$\cos \varphi$
Rated frequency	f_N

When selecting motors the following aspects must be considered:

1. Influence of ambient temperature

The data on the motor rating plate (S1) relate to an ambient temperature of 40 °C. In the case of servomotors it is very often assumed that additional heat discharge is effected via the motor flange. If no additional heat discharge via the motor flange is feasible on servomotors, the rating data must be reduced.

The maximum permissible motor temperature depends on mainly on the insulating materials and impregnating agents used. The insulating materials and impregnating agents are selected according to the thermal class (B, F, H). For detailed project planning data refer to the relevant motor data sheet.

Thermal class (insulating material class)	Limit temperature of insulating material °C	Limit excess temperature of winding K
B	130	80
F	155	105
H	180	125

Table 2.1 Thermal classes of insulating materials

2. Influence of installation altitude

The data on the motor rating plate (S1) relate to an installation altitude of 1000 metres above mean sea level. At an installation altitude above 1000 metres, the permissible rated power output and torque must be reduced.

Typical values are:

Above an installation altitude of 1000 metres above mean sea level the power output and torque must be reduced by 1 % per 100 metres. The maximum installation altitude is typically 4000 m above mean sea level.

For detailed project planning data refer to the relevant motor data sheet.

3. Maximum permissible motor torque

The maximum permissible motor torque is not given on the rating plate. It is given on the motor data sheet.

The maximum permissible motor torque depends mainly on the motor type (standard three-phase AC motor, servomotor) and thus on the M-n characteristic.

As well as the maximum torque, the average bearing life, and thus the axial and lateral forces, are also key. After all, what good is it to the user of the ultra-small motor delivers the maximum torque but fails after 500 hours because of bearing damage.

For detailed project planning data refer to the relevant motor data sheet.



Please also note the limitation of maximum motor torques in the upper speed range and in field weakening.

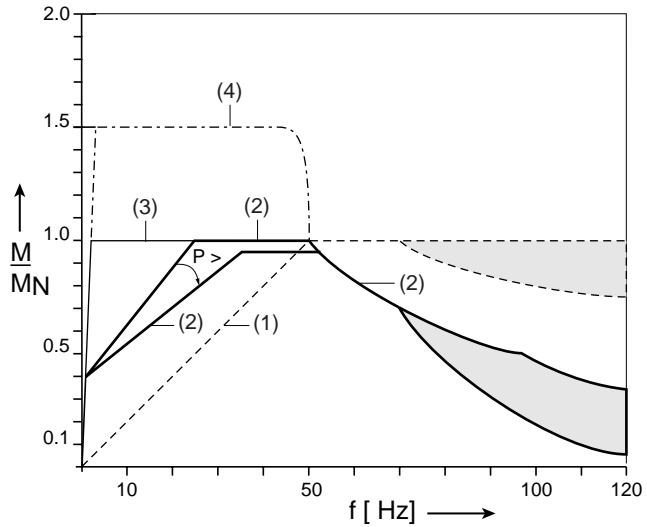


Figure 2.1 M - f characteristic of a standard three-phase AC motor

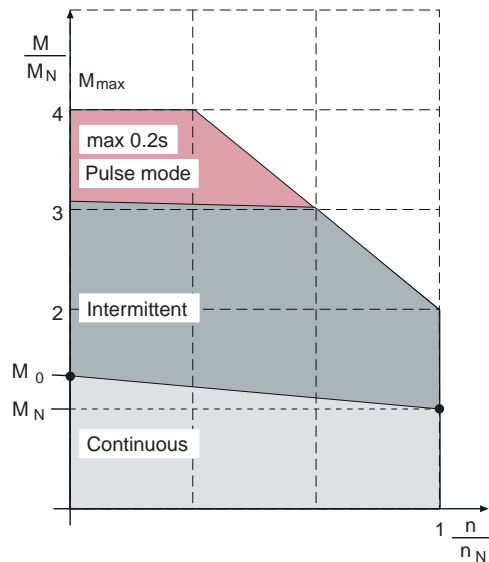


Figure 2.2 M - n characteristic of a synchronous servomotor

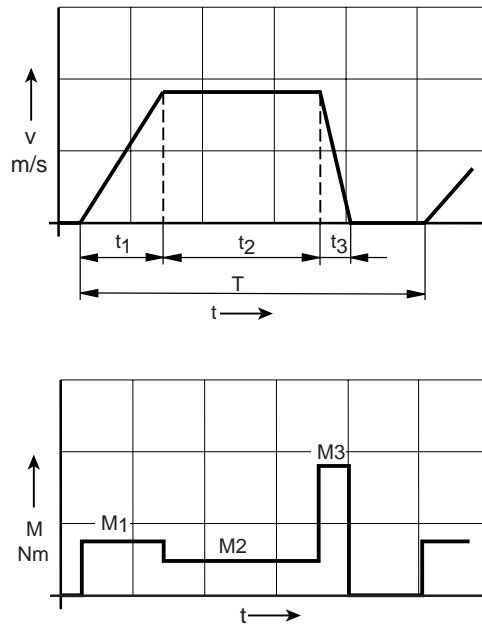
4. Thermal adequacy of the motor

Another limitation is the thermal load on the motor. Under variable load, an equivalent mean load can be calculated which the machine is able to generate without heating up more than is permissible.

The mean equivalent load is calculated by the "effective value method". In calculating by the effective value method, the speed- and voltage-dependent motor idling losses are assumed to be constant. The simplifications made place the effective value determined (I_{eff} , M_{eff} , P_{eff}) on the safe side.

Effective torques of motors without internal cooling

In load cycles in which the switch-on times are short relative to the thermal time constants of the motor, the thermal load capacity of the electric machine can be estimated by way of the effective torque.



$$M_{\text{eff}} = \sqrt{\frac{M_1^2 \cdot t_1 + M_2^2 \cdot t_2 + M_3^2 \cdot t_3}{T}}$$

2.1.1 Selecting a motor

1.

When selecting motors, steps 1 to 3 should be run through repeatedly.

Ambient temperature, mounting type and installation altitude

Determine the application-specific reduction factor when starting to select your motor. The factor is produced from the ambient temperature, the mounting type, the installation altitude and, depending on motor type, from the additional heat discharge via the motor flange. Reduce the data sheet rating data according to the determined factor.

2.

Calculating the key application data

The key items of application data are:

- Maximum motor speed (n_{\max})
- Maximum occurring torques (M_{\max})
- Effective motor torque (M_{eff})
- Mean motor speed ($\bar{n}_{\text{Operating play}}$)

$$\bar{n}_{\text{Operating play}} = \frac{\sum_{i=1}^n |n_i| \cdot t_i}{T_{\text{Operating play}}}$$

3.

Motor selection

For motor selection check the following conditions:

1. The reduction factor to step 1 must be included so that the data sheet rating data (S1) of the selected motor can be adapted.
2. The selected motor must be able to deliver the maximum speed (n_{\max}) even at 10 % undervoltage.
3. The selected motor must be able to deliver the maximum torque at maximum speed (n_{\max}).
4. The selected motor must be able to deliver the effective motor torque (M_{eff}) at mean speed, referred to the M-n characteristic (S1).



If these conditions are met, you must incorporate the additional moment of inertia of the selected motor into your calculations and cross-check the whole thing again.

2.2 Selecting standard three-phase AC motors

A wide variety of asynchronous and synchronous three-phase AC motors can be operated on the c-line drive controllers. The motor type is determined primarily by the rotor introduced into the rotating field. This section deals with the typical characteristic values of the three-phase AC motors most frequently used in practice. They are:

- Standard three-phase AC motor (asynchronous)
- Synchronous servomotor
- Asynchronous servomotor

The following table roughly outlines the differences between the various three-phase AC motor types. The table is based on the power range from 0.37 to 5 kW - that is, the torque range from around 1 Nm to 40 Nm.

Differences between the three-phase AC motor types

Features	Standard three-phase AC motor	Synchronous servomotor	Asynchronous servomotor
Value for money Up to 3 kW [Euro/Nm]	Low	Medium	High
Value for money Above 3 kW [Euro/Nm]	Low	High	Medium
Angular acceleration [M_{\max}/J_{rot}]	Medium	Very good	Good
Speed manipulating range	Good (0 to 2x n_N)	Medium (0 to n_N)	Very good (0 to 4x n_N)
Power density [power to volume/weight]	Medium	Very good	Medium
Rotor moment of inertia	Large	Small	Medium
Standstill torque	Limited ($\approx 30\%$)	Yes	Yes
Protection	IP54	IP64	IP64
Cooling (without external fan)	Internally cooled	Convection	Convection
Max. acceleration torque	1.8 to 2 x M_N	3 x M_N	3 x M_N
Emergency-stop via mechanical motor brake	Yes	Limited	Limited
Repair	Easy	Difficult	Easy
Spares stocking	Easy	Difficult	Medium

Table 2.2 Differences in three-phase AC motor types

2.2.1 Characteristic values of standard three-phase AC motors

Startup characteristic in mains operation

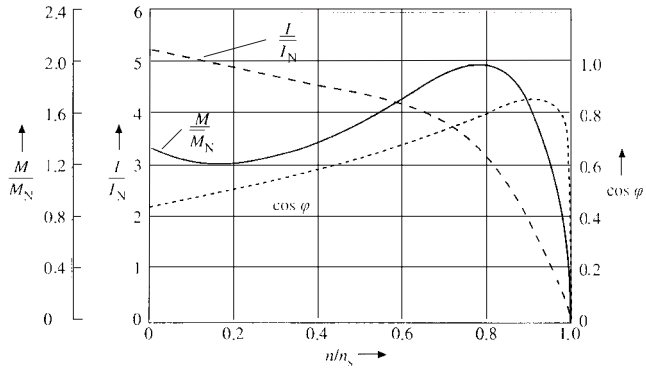


Figure 2.3 Typical startup characteristic of a standard three-phase AC motor in mains operation

Operating characteristic

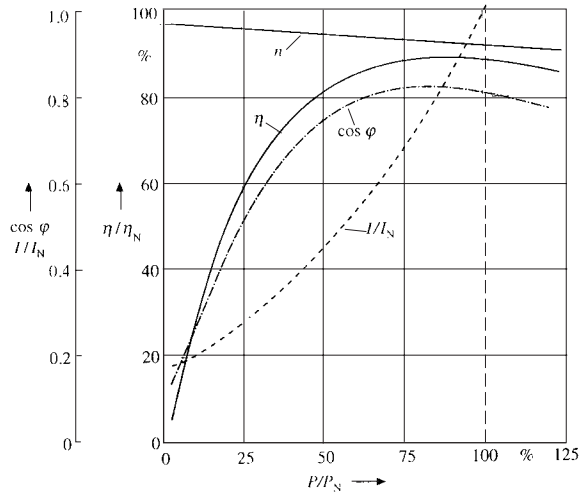
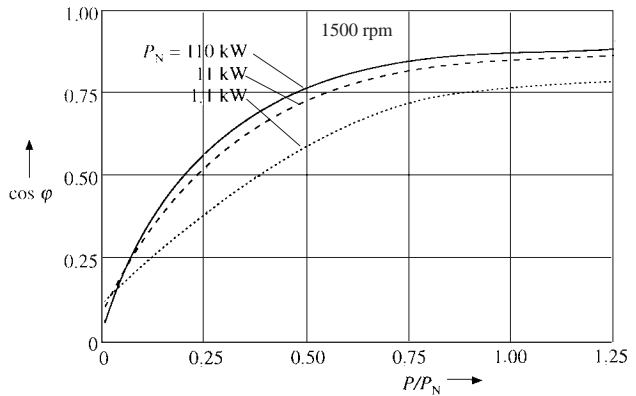


Figure 2.4 Typical operating characteristic of a standard three-phase AC motor

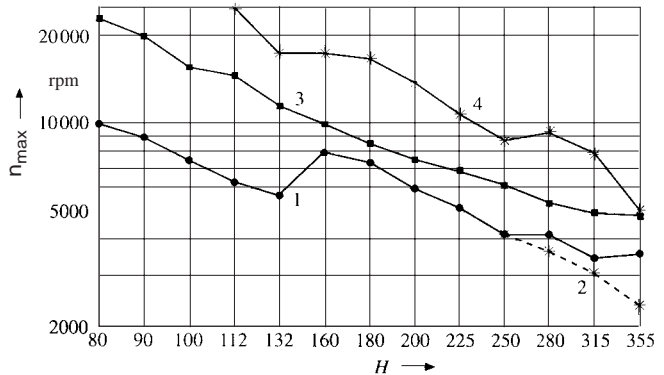
Power factor



P/P_N Load on shaft

Figure 2.5 Power factor $\cos \varphi$ of a four-pole standard three-phase AC motor

Limit speed



n_{\max} Limit speed

H Axis height

1 Greased groove ball bearings in two-pole motors

2 Greased groove ball bearings in four-pole motors and higher

3 Strength of short-circuiting rings of rotor cage

4 Bend-critical speed

Figure 2.6 Typical limit speed of a standard three-phase AC motor



For more information on rotating electric machines, rating and operating behaviour, refer to standard DIN VDE 0530 or EN 60034-1 and the Appendix.

Warranted value for	Tolerances
Efficiency η <ul style="list-style-type: none"> Machines up to 50 kW Machines above 50 kW 	-15 % of $(1 - \eta)$ -10 % of $(1 - \eta)$
Total losses P_V <ul style="list-style-type: none"> Machines up to 50 kW Machines above 50 kW 	No specification + 10 % of P_V
Power factor $\cos \varphi$	-1/6 of $(1 - \cos \varphi)$ At least 0.02; max. 0.07
Slip s (full load, operating temperature) <ul style="list-style-type: none"> Machines below 1 kW Machines above 1 kW 	± 30 % of s ± 20 % of s
Break-away starting current I_1	+20 % of I_1
Break-away torque M_1	-15 % to +25 % of M_1 (by agreement also more than + 25 %)
Pull-up torque M_U	-10 % of M_U
Breakdown torque M_b	-10 % of M_b
Mass moment of inertia J	± 10 % of J

Table 2.3 Tolerances for values of induction machines to VDE 0530



For details of protection, thermal class and PTC configuration refer to Appendix A4.

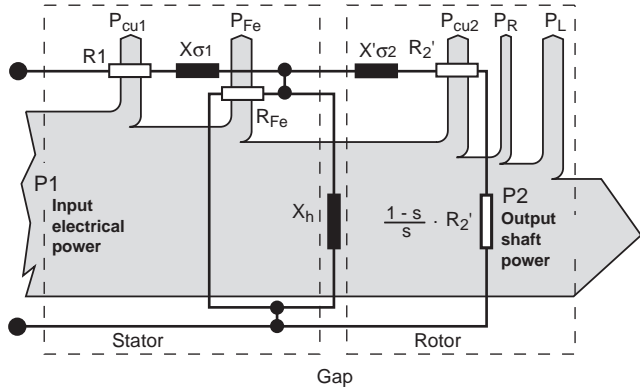


Figure 2.7 Equivalent circuit diagram with total loss balance

$\frac{R_2'}{s}$ can be translated into $R_2' + R_2' \cdot \frac{1-s}{s}$, where $R_2' \cdot \frac{1-s}{s}$ indicates the mechanical load on the motor.

Typical losses of an asynchronous motor	
$P_{cu1} \sim I^2$	Stator winding loss
$P_{cu2} \sim I^2 \sim M^2$	Rotor cage loss
$P_{Fe} \sim n^{1.3} > 15 \text{ kW } n^{1.5}$	Core loss
$P_L \sim n^3 (n^2)$	Fan loss
$P_R \sim n$	Friction loss (bearings)

Limit frequency in VFC mode

$$f_G \approx f_N \cdot \left(\frac{M_K}{M_N} \right) \cdot 0.7$$

Dependencies of the motor variables in drive controller operation

Variable	Referenced variable	Characteristic of referenced variable		
		Constant flux		Field weakening
		M=const.	P ₂ =const.	P ₂ ~ 1/n
Speed [n]	$\frac{n}{n_N}$			
Voltage [U]	$\frac{U}{U_N}$			
Flux [Φ]	$\frac{\Phi}{\Phi_N}$			
Current [I]	$\frac{I}{I_N}$			
Torque [M]	$\frac{M}{M_N}$			
Breakdown torque [M _K]	$\frac{M_K}{M_{KN}}$			
Mechanical output [P ₂]	$\frac{P_2}{P_N}$			
Slip [s]	$\frac{s}{s_N}$			
Stator copper loss [P _{cu1}]	$\frac{P_{cu1}}{P_{cu1N}}$			
Rotor copper loss [P _{cu2}]	$\frac{P_{cu2}}{P_{cu2N}}$			
Core loss [P _{Fe}]	$\frac{P_{Fe}}{P_{FeN}}$			

Table 2.4 Dependencies of the motor variables in Voltage Frequency Control mode

Abbreviations used in Table 2.4

f	Frequency
f_N	Rated frequency
f_G	Limit frequency in drive controller operation
I	Current, effective value
I_N	Rated current
M	Torque
M_k	Breakdown torque
M_{kN}	Rated breakdown torque
M_N	Rated torque
n	Speed
n_N	Rated speed
P_{cu1}	Stator copper loss
P_{cu2}	Rotor copper loss
$P_{cu1, N}$	Rated stator copper loss of fundamental
$P_{cu2, N}$	Rated rotor copper loss of fundamental
P_{Fe}	Core loss
P_N	Rated power output
P_2	Mechanical output
s	Slip
U	Voltage, effective value
Φ	Magnetic flux



Achtung: Safe drive controller operation can only be guaranteed when the max. output frequency is not higher than the limit frequency (f_G).

Initial commissioning automatically optimizes the control circuits such that, with drive controller output assigned equal to motor output, the typical power output and torque characteristic shown in Figure 2.8 is produced.

Typical torque characteristic of a standard three-phase AC motor in drive controller operation $P_{\text{drive controller}} = P_{\text{motor}}$

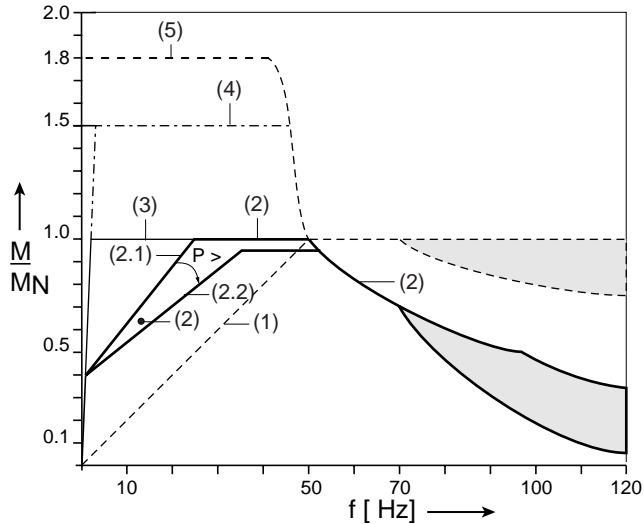


Figure 2.8 Typical torque characteristic of a standard three-phase AC motor

- (1) Delivered power output of a standard three-phase AC motor in standard drive controller operation
- (2) Permissible torque characteristic of an internally cooled standard three-phase AC motor in standard drive controller operation
 - (2.1) Typical characteristic at motor power outputs <4 kW
 - (2.2) Typical characteristic at motor power outputs >15 kW



Precise data can only be given by the manufacturers of the motors.

- (3) Permissible torque characteristic of an adequately externally cooled standard three-phase AC motors with standard drive controller. It should, however, be noted that at motor power outputs >15 kW a rotor fan is very often used, meaning that the characteristic (3) may need to be reduced.



Precise data can only be given by the manufacturers of the motors.

- (4) Maximum permissible torque of a standard three-phase AC motor to VDE 0530 part 1 (120 s).
Maximum torque with drive controller modules which permit 150 % overload and have activated motor control method SFC or FOR.
- (5) Maximum torque with drive controller modules which permit 180 % overload and have activated motor control method SFC or FOR.



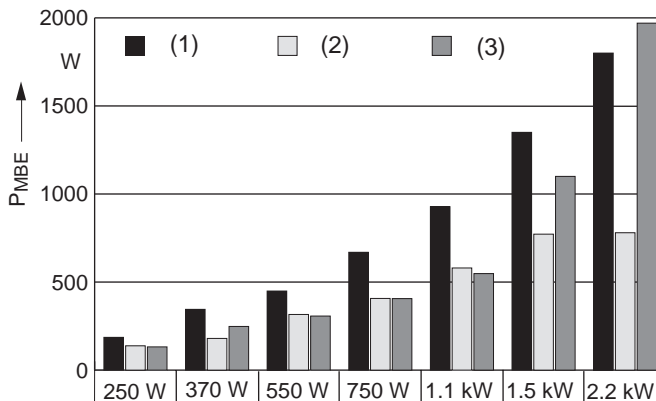
The typical limit curve (2) can be increased by around 20 % with motor insulation to thermal class "F" and usage of the motor to (thermal class B). Precise specifications can be obtained from your motor manufacturer.

Typical acceleration behaviour of standard three-phase AC motors

$$P_{\text{MBE}} = \frac{J_M \cdot n^2}{9,2 \cdot t_{\text{BE}}}$$

J_M Motor moment of inertia (rotor) in [kgm²]
 t_{BE} Acceleration time in [s]
 P_{MBE} Motor acceleration power in [W]

Acceleration from
0 rpm to rated speed
in 100 ms



(1)	186	345	449	669	928	1350	1800
(2)	138	180	316	407	580	772	780
(3)	132	248	307	406	548	1100	1970

- (1) 1 pole pair
- (2) 2 pole pairs
- (3) 3 pole pairs

Figure 2.9 Acceleration behaviour as a function of number of pole pairs of standard three-phase AC motor



In summary

Motors with one pole pair are unsuitable for dynamic drive tasks.

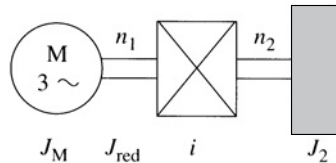
As the diagram shows, standard three-phase AC motors with two pole pairs (four-pole) are particularly well suited to dynamic drive tasks.

Typical max. acceleration times of four-pole standard three-phase AC motors

Size	Power P in W	Idle acceleration time in ms [$I_{red}=0$]	Acceleration time with moment of inertia adaptation in ms [$I_{red}=I_M$]
63L/4	250	55	110
71L/4	375	49	98
80/S/4	550	57	114
80L/4	750	54	108
90S/4	1100	52	104
90L/4	1500	52	104
90L/4a	2200	35	70
100L/4	2200	50	100
100L/4a	3000	50	100
112M/4	4000	123	246

Table 2.5 Max. acceleration times of four-pole standard three-phase AC motors

Example: Equations for reduction via a gearbox



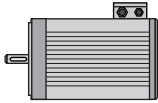
$$J_{red} = \frac{J_2}{(i)^2} = \frac{J_2}{(n_1 / n_2)^2}$$

$$J_{tot} = J_M + J_{red}$$

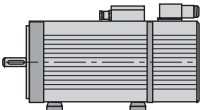


For further calculations of mass moments of inertia see see Appendix A.2.8.

2.2.2 Characteristic values of asynchronous servomotors

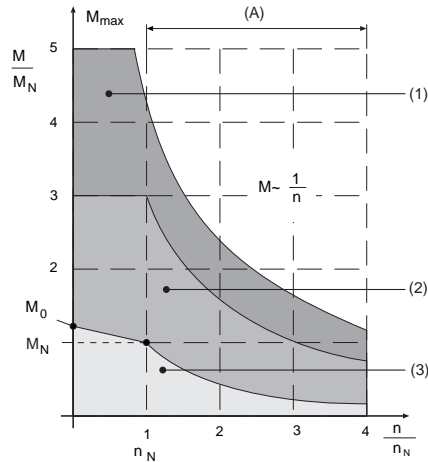


Without encoder



With encoder

M-n characteristic for asynchronous servomotors



(1) Pulse mode (2) Intermittent (3) Continuous (S1)

Figure 2.10 M-n characteristic for asynchronous motors

Abbreviations used

Term	Notes
M_0 Standstill torque	Thermal limit torque of the motor at standstill. The motor can deliver this torque for an unlimited length of time.
I_0 Standstill current	R.m.s. value of the motor phase current required to generate the standstill torque.
M_N Rated torque	Thermal limit torque of the motor at rated speed n_N .
I_N Rated current	R.m.s. value of the motor phase current required to generate the nominal torque.
P_N Rated power	Continuous power output of the motor at the nominal operation point (M_N , n_N) at rated current I_N and rated voltage U_N .
M_{max} , I_{max} Limit characteristic	A maximum of five times the rated current may be applied to the motors.

Table 2.6 Abbreviations used

Typical norms and properties

Characteristic	Asynchronous servomotors
Machine type	Asynchronous servomotor
Design (DIN 42948)	IM B35, IM B5, BV1, V3
Protection (DIN 40050)	IP54
Insulating material class	Insulating material class F to IEC85/VDE0530 $\Delta t = 105$, coolant temperature $t_u = +40$ °C
Cooling	Self-cooling (IC 0041) IP65 Forced cooling (IC 0641) IP44.54
Shaft end on the A side	Cylindrical shaft end DIN 748, featherkey and featherkey way DIN 6885, tolerance band k6
Smooth running, coaxiality and concentricity to DIN 42955	Tolerance N (normal) R (reduced) on request
Vibration severity to ISO 2373	Grade N, optionally R
Therm. Motor monitor	PTC thermistor in stator winding
Torque load	To prevent thermal motor overloading, the effective load moment at medium speed must not be above curve S1. $M_{\text{eff}} = \sqrt{\frac{\sum (M_n^2 \times t_n)}{t_{\text{tot}}}} \quad \bar{n} = \frac{\sum (n_n \cdot t_n)}{t_{\text{tot}}}$
Maximum pulse torque	Typically 2 to 5 times nominal torque, depending on controller assignment. 3 to 5 times nominal torque is permissible for max. 0.2 s.
Bearing life	The average service life under nominal conditions ($M_{\text{max.}} \leq M_N$) is 20.000 h.

Table 2.7 General technical data

Typical max. acceleration times of asynchronous servomotors





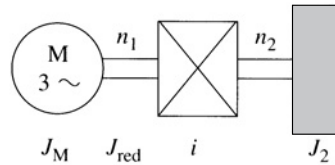
Installation window [mm]	Acceleration torque [Nm]	Power class [kW]	Idle acceleration time [ms] $I_{red}=0$	Acceleration time [ms] $I_{red}=I_M$
 110x110	3.25 to 11.75	0.4 to 1.5	14 to 12	28 to 24
 140x140	8.75 to 32.5	1.1 to 2.7	20 to 19	40 to 38
 190x190	32.5 to 87.5	2.1 to 5.5	34 to 38	68 to 76
 260x260	100 to 175	6.3 to 11	71 to 87	142 to 174
Precondition: Acceleration from 0 to 1500rpm at 2.5 times rated torque				

Table 2.8 Acceleration times

Example: Equations for reduction via a gearbox



$$J_{red} = \frac{J_2}{(i)^2} = \frac{J_2}{(n_1/n_2)^2}$$

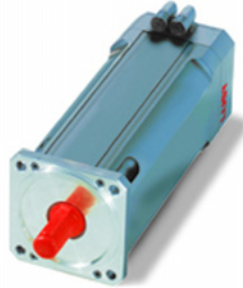
$$J_{tot} = J_M + J_{red}$$



For calculations of mass moments of inertia see section A.2.8.

2.2.3 Characteristic values of LSH servomotors

The LSH synchronous servomotors described in the following are designed with a special compressed winding technology. This new winding technology has many advantages over conventional winding technology.



Use of compressed winding technology

1. Use of compressed winding technology eliminates the need for the conventional winding head, so enabling the length of the motors to be reduced by as much as 50 %.
2. Lower rotor moment of inertia combined with higher torque permits up to 100 % higher motor dynamics.
3. Reduced acquisition cost based on higher torque in same motor design combined with reduced manufacturing cost and material input.



The following sample data are taken from the servo motor catalogue LSx.

Typical M-n characteristic for synchronous servomotors

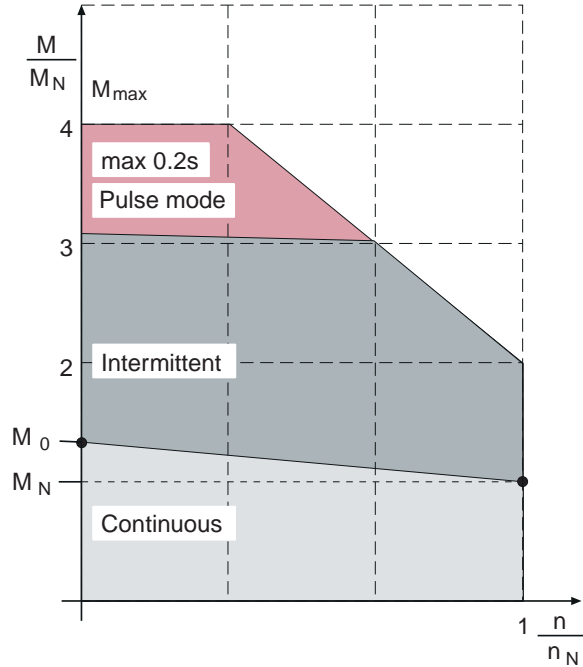


Figure 2.11 Operation mode characteristics

Abbreviations used

Term	Notes
M_0 Standstill torque	Thermal limit torque of the motor at standstill. The motor can deliver this torque for an unlimited length of time.
I_0 Standstill current	R.m.s. value of the motor phase current required to generate the standstill torque.
M_N Rated torque	Thermal limit torque of the motor at rated speed n_N .
I_N Rated current	R.m.s. value of the motor phase current required to generate the nominal torque.
P_N Rated power	Continuous power output of the motor at the nominal operation point (M_N , n_N) at rated current I_N and rated voltage U_N .
M_{MAX} , I_{MAX} Limit characteristic	A maximum of four times the rated current may be applied to the motors.

Basic configuration of LSH servomotors

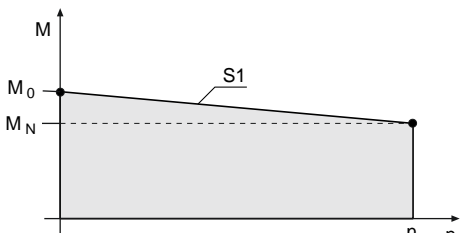
Characteristic	Synchronous servomotor LSH
Machine type	Permanent-field synchronous servomotor
Magnet material	Neodymium-iron-boron
Design (DIN 42948)	B5, V1, V3
Protection (DIN 40050)	IP64, IP54 to EN60034-5 (circulating machines), IP65 optionally available
Insulating material class	Insulating material class F to IEC85/VDE0530, winding excess temperature $\Delta t = 100\text{ }^\circ\text{C}$, ambient temperature $t_{\text{U}} = +40\text{ }^\circ\text{C}$
Coating	RAL 9005 (matt black)
Shaft end on A-side	Smooth shaft (featherkey and featherkey way DIN 6885, tolerance band k6 as option)
Accurate true running, coaxiality and runout to DIN 42955	Tolerance N (normal), tolerance R (reduced) on request
Vibration severity to ISO 2373	Grade N, optionally R
Thermal motor monitoring	DIN-PTC in a stator winding
Torque load	<p>To prevent thermal motor overloading, the effective load moment at medium speed must not be above curve S1.</p> 
	$M_{\text{eff}} = \sqrt{\frac{\sum(M_n^2 \times t_n)}{t_{\text{tot}}}}$ $\bar{n} = \frac{\sum(n_n \cdot t_n)}{t_{\text{tot}}}$
Maximum pulse torque	Typically 2 to 4 times nominal torque for max. 0.2 s, depending on controller assignment
Bearing life	The average service life under nominal conditions ($M_{\text{max}} \leq M_N$) is 20.000 h.
Termination mode of motor, thermistor and holding	Via plug-in terminals
Termination mode of encoder system	Signal plug (mating plug not supplied)

Table 2.9 Basic configuration of LSH servomotors

Cooling of LSH servomotors

The specified nominal data relate to a max. ambient temperature of 40 °C and mounting of the motor on an aluminium plate with a max. temperature of 40 °C and installed at an altitude of max. 1000 m above MSL.

Minimum mounting area: 2.5 x area of motor flange

Thickness of mounting area: min. 10 mm

If the motor is mounted with insulation (no heat discharge via the flange) the nominal torque must be reduced.

For installations above an altitude of > 1000 m above MSL the power output must be reduced by 1 % per 100 metres. The maximum installation altitude is 4000 metres.

At ambient temperatures > 40 °C the power output must be reduced by 1 % per 1°C. The maximum ambient temperature is 50 °C.

Design, axial and lateral forces of LSH servomotors

Sizes	Radial force F_{Rm} [N] at speed n [rpm]					Axial force F_{Am} [N] at speed n [rpm]					F_G [N]
	1000	2000	3000	4500	6000	1000	2000	3000	4500	6000	
LSH-050-1	310	250	220	190	170	60	50	42	36	32	2
LSH-050-2											
LSH-050-3											
LSH-074-1	480	380	330	290	260	90	70	63	55	50	6
LSH-074-2											
LSH-074-3											
LSH-097-1	850	680	600	520	470	160	130	115	100	90	15
LSH-097-2											
LSH-097-3											

Table 2.10 Forces of LSH servomotors

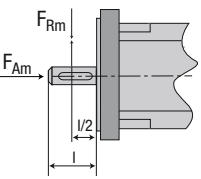
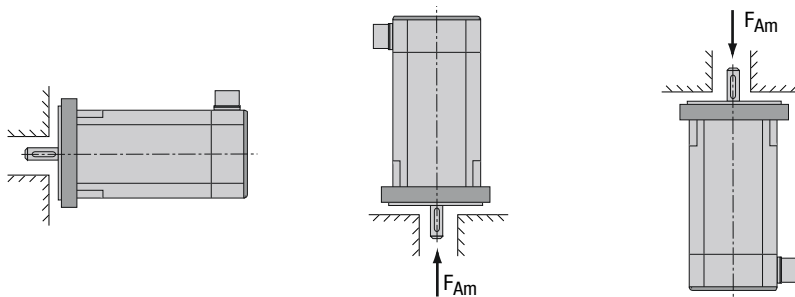
Sizes	Radial force F_{Rm} [N] at speed n [rpm]					Axial force F_{Am} [N] at speed n [rpm]					F_G
	1000	2000	3000	4500	6000	1000	2000	3000	4500	6000	[N]
LSH-127-1	970	770	670	590	530	185	145	125	110	100	34
LSH-127-2											
LSH-127-3											
LSH-127-4											
						<p>The table indicates the max. permissible lateral force (radial force F_{Rm}) at the point of application $l/2$ and the max. permissible axial force F_{Am} for a bearing lifetime of 20.000 h. A lateral force not applied in the middle of the shaft end can simply be translated to allow for the changed lever ratios. Either the permissible radial force or the axial force may act on the motor shaft!</p>					

Table 2.10 Forces of LSH servomotors



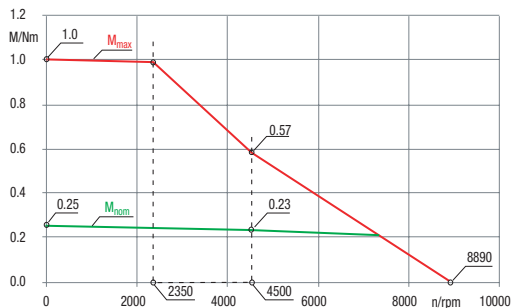
Design	B5	V1	V3
Shaft	Free shaft end	Free shaft end at bottom	Free shaft end at top
Attachment	Flange mounting Access from housing side	Flange mounting at bottom Access from housing side	Flange mounting at top Access from housing side



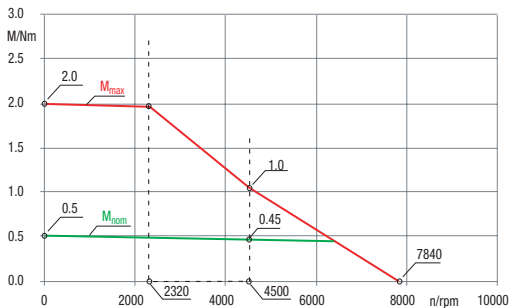
With vertical mounting (V1) the permissible axial forces (F_{Am}) apply. With vertical upward mounting (V3) the permissible axial forces are reduced by the force due to weight of the rotor (F_G).

Synchronous servomotor LSH-50

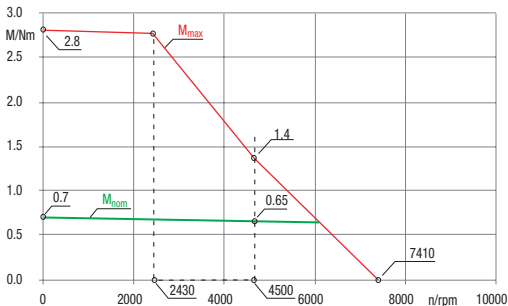
LSH-050-1-45-320



LSH-050-2-45-320



LSH-050-3-45-320



Tech. data	Symbols	LSH-050-1-45-320	LSH-050-2-45-320	LSH-050-3-45-320
Rated speed	n_n	4500 rpm	4500 rpm	4500 rpm
Rated frequency	f_N	225 Hz	225 Hz	225 Hz
DC link voltage (controller)	U_{dc}	320 V	320 V	320 V
Rated voltage	U_n	200 V	200 V	200 V
Nominal torque	M_n	0.23 Nm	0.45 Nm	0.65 Nm
Rated current	I_n	0.66 A	1.11 A	1.49 A
Standstill torque	M_0	0.25 Nm	0.50 Nm	0.70 Nm
Standstill current	I_0	0.67 A	1.19 A	1.57 A

Table 2.11 Technical data of synchronous servomotors LSH-50

Tech. data	Symbols	LSH-050-1-45-320	LSH-050-2-45-320	LSH-050-3-45-320
Maximum permissible torque	M_{\max}	1.0 Nm	2.0 Nm	2.8 Nm
Maximum permissible current	I_{\max}	2.9 A	5.1 A	6.7 A
Maximum permissible speed	n_{\max}	12000 rpm	12000 rpm	12000 rpm
Voltage constant	K_E	22.5 V/1000	25.5 V/1000	27.0 V/1000
Torque constant	K_T	0.37 Nm/A	0.42 Nm/A	0.45 Nm/A
Winding resistance (two phases)	R_{2ph}	33.1 Ω	16.4 Ω	11.1 Ω
Winding inductance (two phases)	L_{2ph}	51 mH	32.7 mH	24.5 mH
Idling speed	n_0	8890 rpm	7840 rpm	7410 rpm
Electrical time constant	T_{el}	1.5 ms	2.0 ms	2.2 ms
Thermal time constant	T_{th}	13 min.	15 min.	20 min.
Moment of inertia of the motor	J	0.06 kgcm ²	0.08 kgcm ²	0.10 kgcm ²
Mass	m	0.75 kg	0.92 kg	1.1 kg
Brake (optional)	J	0.07 kgcm ²	0.07 kgcm ²	0.07 kgcm ²
	m	0.2 kg	0.2 kg	0.2 kg

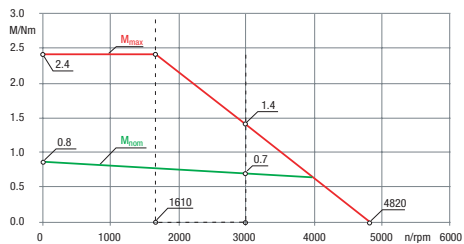
Table 2.11 *Technical data of synchronous servomotors LSH-50*

Synchronous servomotor LSH-074

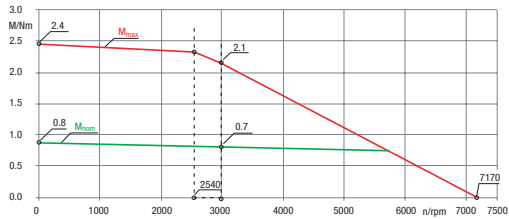
$U_{ZK} = 320\text{ V}$

$U_{ZK} = 560\text{ V}$

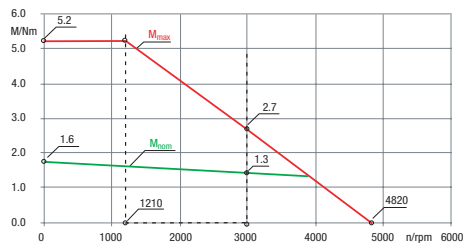
LSH-074-1-30-320



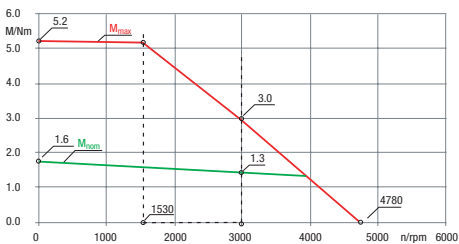
LSH-074-1-30-560



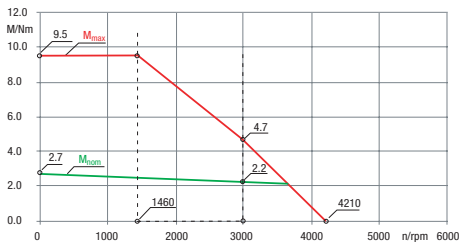
LSH-074-2-30-320



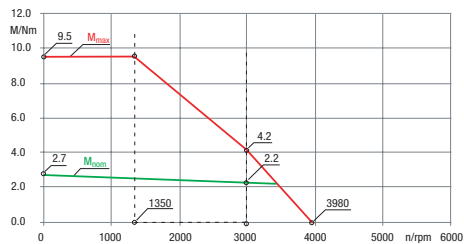
LSH-074-2-30-560



LSH-074-3-30-320



LSH-074-3-30-560



Tech. data	Symbols	LSH-074-1-30-320	LSH-074-1-30-560	LSH-074-2-30-320	LSH-074-2-30-560	LSH-074-3-30-320	LSH-074-3-30-560
Rated speed	n_n	3000 rpm	3000 rpm	3000 rpm	3000 rpm	3000 rpm	3000 rpm
Rated frequency	f_N	250 Hz	250 Hz	250 Hz	250 Hz	250 Hz	250 Hz
DC link voltage	U_{dc}	320 V	560 V	320 V	560 V	320 V	560 V
Rated voltage	U_n	200 V	330 V	200 V	330 V	200 V	330 V
Nominal torque	M_n	0.70 Nm	0.70 Nm	1.3 Nm	1.3 Nm	2.2 Nm	2.2 Nm
Rated current	I_n	1.11 A	1.0 A	2.0 A	1.2 A	2.9 A	1.68 A
Standstill torque	M_0	0.80 Nm	0.8 Nm	1.6 Nm	1.6 Nm	2.7 Nm	2.7 Nm
Standstill current	I_0	1.17 A	1.05 A	2.3 A	1.4 A	3.4 A	1.97 A
Maximum permissible torque	M_{max}	2.4 Nm	2.4 Nm	5.2 Nm	5.2 Nm	9.5 Nm	9.5 Nm
Maximum permissible current	I_{max}	5.1 A	4.6 A	11.1 A	6.7 A	18.0 A	10.3 A
Maximum permissible speed	n_{max}	12000 rpm	12000 rpm	12000 rpm	12000 rpm	12000 rpm	12000 rpm
Voltage constant	K_E	41.5 V/1000	46.0 V/1000	41.5 V/1000	69.0 V/1000	47.5 V/1000	83.0 V/1000
Torque constant	K_T	0.69 Nm/A	0.76 Nm/A	0.69 Nm/A	1.14 Nm/A	0.79 Nm/A	1.37 Nm/A
Winding resistance (two phases)	R_{2ph}	9.9 Ω	12.6 Ω	4.0 Ω	11.6 Ω	2.1 Ω	6.6 Ω
Winding inductance (two phases)	L_{2ph}	36.0 mH	44.7 mH	18 mH	49.4 mH	11.8 mH	36.7 mH
Idling speed	n_0	4820 rpm	7170 rpm	4820 rpm	4780 rpm	4210 rpm	3980 rpm
Electrical time constant	T_{el}	3.6 ms	3.5 ms	4.5 ms	4.3 ms	5.5 ms	5.6 ms
Thermal time constant	T_{th}	25 min.	25 min.	30 min.	30 min.	33 min.	33 min.
Moment of inertia of the motor	J	0.50 kgcm ²	0.50 kgcm ²	0.70 kgcm ²	0.70 kgcm ²	1.1 kgcm ²	1.1 kgcm ²
Mass	m	1.5 kg	1.5 kg	2.1 kg	2.1 kg	3.2 kg	3.2 kg
Brake (optional)	J	0.2 kgcm ²	0.2 kgcm ²	0.2 kgcm ²	0.2 kgcm ²	0.2 kgcm ²	0.2 kgcm ²
	m	0.47 kg	0.47 kg	0.47 kg	0.47 kg	0.47 kg	0.47 kg

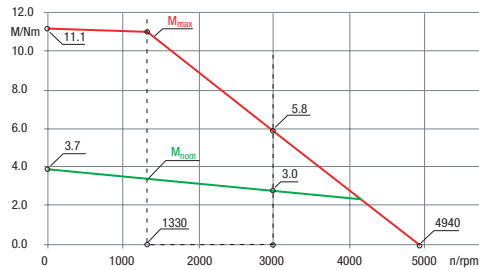
Table 2.12 Technical data of synchronous servomotors LSH-074

Synchronous servomotor LSH-097

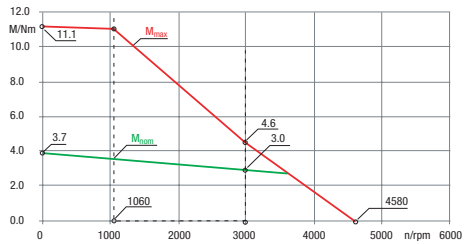
$U_{ZK} = 320\text{ V}$

$U_{ZK} = 560\text{ V}$

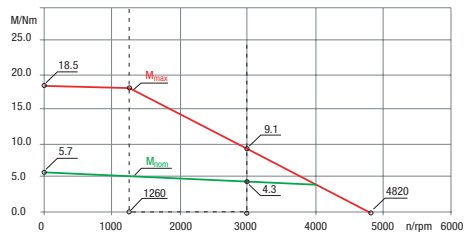
LSH-097-1-30-320



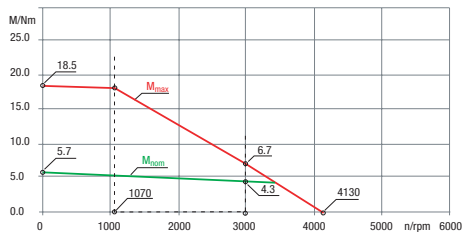
LSH-097-1-30-560



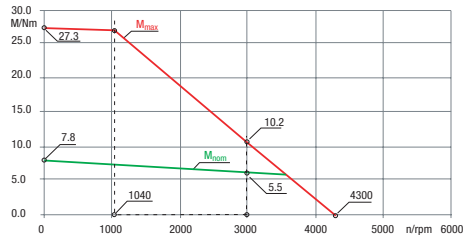
LSH-097-2-30-320



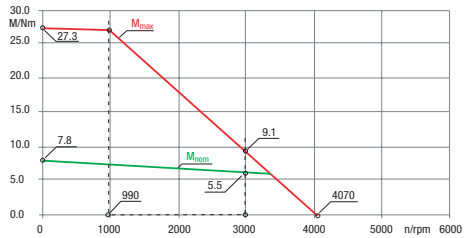
LSH-097-2-30-560



LSH-097-3-30-320



LSH-097-3-30-560



Tech. data	Symbols	LSH-097-1-30-320	LSH-097-1-30-560	LSH-097-2-30-320	LSH-097-2-30-560	LSH-097-3-30-320	LSH-097-3-30-560
Rated speed	n_n	3000 rpm	3000 rpm	3000 rpm	3000 rpm	3000 rpm	3000 rpm
Rated frequency	f_N	250 Hz	250 Hz	250 Hz	250 Hz	250 Hz	250 Hz
DC link voltage (controller)	U_{dc}	320 V	560 V	320 V	560 V	320 V	560 V
Rated voltage	U_n	200 V	330 V	200 V	330 V	200 V	330 V
Nominal torque	M_n	3.0 Nm	3.0 Nm	4.3 Nm	4.3 Nm	5.5 Nm	5.5 Nm
Rated current	I_n	4.7 A	2.6 A	6.6 A	3.4 A	7.5 A	4.3 A
Standstill torque	M_0	3.7 Nm	3.7 Nm	5.7 Nm	5.7 Nm	7.8 Nm	7.8 Nm
Standstill current	I_0	5.5 A	3.1 A	8.3 A	4.3 A	10.1 A	5.8 A
Maximum permissible torque	M_{max}	11.1 Nm	11.1 Nm	18.5 Nm	18.5 Nm	27.0 Nm	27.0 Nm
Maximum permissible current	I_{max}	24.0 A	15.5 A	40.0 A	21 A	53.0 A	31.0 A
Maximum permissible speed	n_{max}	9000 rpm	9000 rpm	9000 rpm	9000 rpm	9000 rpm	9000 rpm
Voltage constant	K_E	40.5 V/1000	72.0 V/1000	41.5 V/1000	80.0 V/1000	46.5 V/1000	81.0 V/1000
Torque constant	K_T	0.67 Nm/A	1.19 Nm/A	0.69 Nm/A	1.32 Nm/A	0.77 Nm/A	1.34 Nm/A
Winding resistance (two phases)	R_{2ph}	1.24 Ω	4.0 Ω	0.7 Ω	2.7 Ω	0.59 Ω	1.81 Ω
Winding inductance (two phases)	L_{2ph}	10.6 mH	34.0 mH	6.9 mH	25.0 mH	6.2 mH	18.6 mH
Idling speed	n_0	4940 rpm	4580 rpm	4820 rpm	4130 rpm	4300 rpm	4070 rpm
Electrical time constant	T_{el}	8.5 ms	8.5 ms	9.9 ms	9.3 ms	10.5 ms	10.3 ms

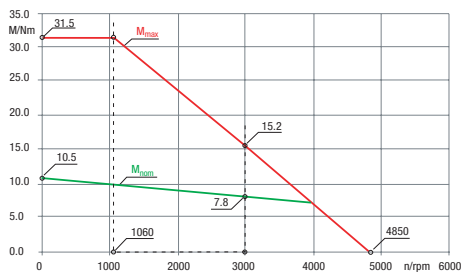
Table 2.13 Technical data of synchronous servomotors LSH-097

Tech. data	Symbols	LSH-097-1-30-320	LSH-097-1-30-560	LSH-097-2-30-320	LSH-097-2-30-560	LSH-097-3-30-320	LSH-097-3-30-560
Thermal time constant	T_{th}	29 min.	29 min.	31 min.	31 min.	33 min.	33 min.
Moment of inertia of the motor	J	1.7 kgcm ²	1.7 kgcm ²	2.6 kgcm ²	2.6 kgcm ²	3.5 kgcm ²	3.5 kgcm ²
Mass	m	4.3 kg	4.3 kg	5.5 kg	5.5 kg	6.7 kg	6.7 kg
Brake (optional)	J	0.82 kgcm ²	0.82 kgcm ²	0.82 kgcm ²	0.82 kgcm ²	0.82 kgcm ²	0.82 kgcm ²
	m	0.61 kg	0.61 kg	0.61 kg	0.61 kg	0.61 kg	0.61 kg

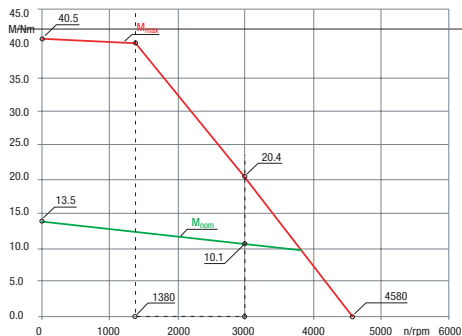
Table 2.13 Technical data of synchronous servomotors LSH-097

Synchronous servomotor LSH-127

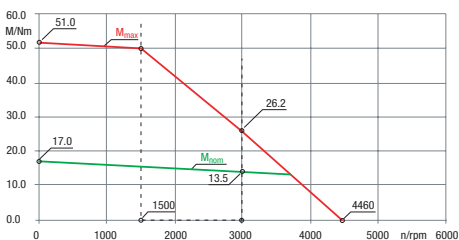
LSH-127-1-30-560



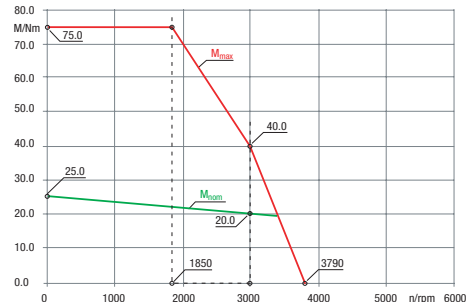
LSH-127-2-30-560



LSH-127-3-30-560



LSH-127-4-30-560



Tech. data	Symbols	LSH-127-1-30-560	LSH-127-2-30-560	LSH-127-3-30-560	LSH-127-4-30-560
Rated speed	n_n	3000 rpm	3000 rpm	3000 rpm	3000 rpm
Rated frequency	f_N	250 Hz	250 Hz	250 Hz	250 Hz
DC link voltage (controller)	U_{dc}	560 V	560 V	560 V	560 V
Rated voltage	U_n	330 V	330 V	330 V	330 V
Nominal torque	M_n	7.8 Nm	10.1 Nm	13.5 Nm	20.0 Nm
Rated current	I_n	7.3 A	9.0 A	11.6 A	14.2 A
Standstill torque	M_0	10.5 Nm	13.5 Nm	17.0 Nm	25.0 Nm
Standstill current	I_0	9.3 A	11.3 A	13.9 A	17.4 A
Maximum permissible torque	M_{max}	32 Nm	41.0 Nm	51.0 Nm	75.0 Nm
Maximum permissible current	I_{max}	49.0 A	49.0 A	57.0 A	68.0 A
Maximum permissible speed	n_{max}	6000 rpm	6000 rpm	6000 rpm	6000 rpm
Voltage constant	K_E	68.0 V/1000	72.0 V/1000	74.0 V/1000	87.0 V/1000
Torque constant	K_T	1.12 Nm/A	1.19 Nm/A	1.22 Nm/A	1.44 Nm/A
Winding resistance (two phases)	R_{2ph}	0.71 Ω	0.48 Ω	0.35 Ω	0.35 Ω
Winding inductance (two phases)	L_{2ph}	11.4 mH	8.5 mH	6.7 mH	6.8 mH
Idling speed	n_0	4850 rpm	4580 rpm	4460 rpm	3790 rpm
Electrical time constant	T_{el}	16.1 ms	17.7 ms	19.1ms	19.4 ms
Thermal time constant	T_{th}	50 min.	55 min.	60 min.	75 min.
Moment of inertia of the motor	J	6.8 kgcm ²	8.3 kgcm ²	11.0 kgcm ²	15.3 kgcm ²
Mass	m	9.5 kg	10.8 kg	13.50 kg	18.5 kg
Brake (optional)	J	1.85 kgcm ²	1.85 kgcm ²	1.85 kgcm ²	1.85 kgcm ²
	m	1.8 kg	1.8 kg	1.8 kg	1.8 kg

Table 2.14 Technical data of synchronous servomotors LSH-127

Selecting the drive controller

After selecting the correct motor for your application as described in section 2.1, you need to determine the matching servocontroller.

In this: The rated current of the drive controller must be at least as high as the effective current required by the application (the motor):

$$I_{\text{eff Drive controller}} \geq \frac{M_{\text{eff of application}}}{K_T}$$

.... where K_T is the torque constant of the servomotor [Nm/A] => see LSH motor data. The torque constant K_T is calculated from M_0 / I_0

.... Also: The short-time possible maximum current of the drive controller must be at least as high as the maximum current (e.g. acceleration/braking torque) required by the application (the motor).

$$I_{\text{max Drive controller}} \geq \frac{M_{\text{max of application}}}{K_T}$$

The torque constant K_T is virtually constant in the range up to around 1.5 times the standstill torque. It should be noted that above 1.5 times the standstill torque the torque constant flattens off. That means that in this overload range disproportionately more motor current is needed to attain a linear rise in motor torque.

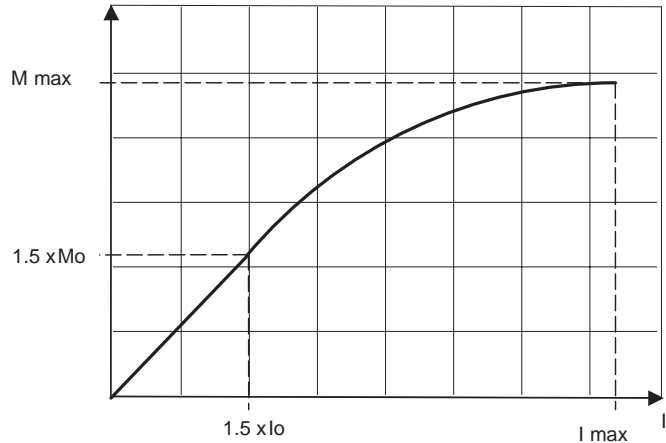


Figure 2.12 Typical torque characteristic as a function of the motor current

The characteristic (Figure 2.12) indicates the typical course of the torque constant K_T at motor standstill. If, for example, a maximum torque of double the standstill torque is required in the application, a safe option in selecting the controller is to place the maximum motor torque proportionate to the maximum motor current in place of K_T .

In this case the approximation is:

$$I_{\max \text{ Drive controller}} \geq \frac{M_{\max \text{ of application}}}{\frac{M_{\max \text{ Motor}}}{I_{\max \text{ Motor}}}}$$

Of course, losses also occur in the motor (core loss and friction loss) as the speed rises. A non-torque-forming portion of the motor current is also required for this. This is reflected in a falling torque characteristic as the speed rises:

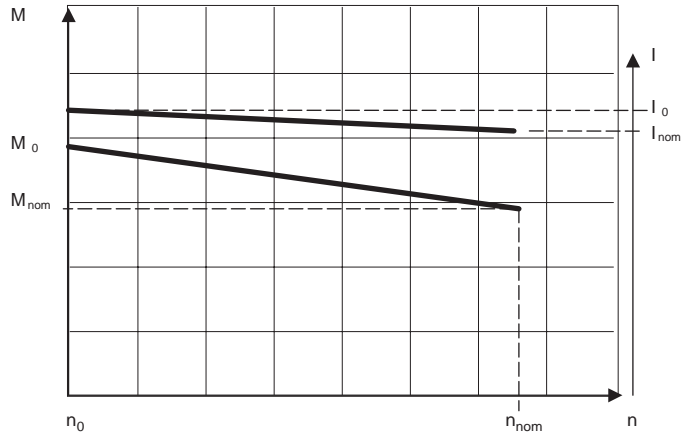


Figure 2.13 Thermally permissible torque and motor current as a function of speed

On the left-side X-axis the torque characteristic is plotted above the speed, while on the right-side X-axis the corresponding typical characteristic of the motor current is shown.

The typical torque characteristic shows clearly that the constant K_T applies only at standstill, because:

$$K_T = \frac{M_0}{I_0} > \frac{M_N}{I_N}$$

In nominal operation the necessary motor current ($=I_{\text{nominal drive controller}}$) can simply be taken from the motor data.

Example of a conversion to a different motor characteristic

With increasing speed a synchronized servo motor only requires a higher voltage reserve. The required motor current mainly depends on the necessary torque and is only insignificantly affected by the speed.

This characteristic of synchronized servo motors can be utilized in order to achieve a higher speed by applying higher motor voltage.

LS servo motors for a d.c. link direct voltage (U_{dc}) of 320 V has the same voltage insulation strength, as the LS servo motors for a d.c. link direct voltage of 560 V (exception: LST-037 motors). This is why a motor for $U_{dc} = 320$ V must only be operated with $U_{dc} = 560$ V. This prerequisite opens the possibility to operate the motor with higher rotary speeds.



-
- This method is not suitable for continuous operation of LSH motors at speeds higher than the specified rated speed! This method is only permitted for short-term operation of LSH motors in the higher speed range.
Or for continuous operation of LST motors in the speed range up to 6000 rpm (applies for all LST motors from size LST-097).
With this type of drive design one must strictly bear in mind, that the motor losses will also increase with rising speed. The rated torque must thus be considerably reduced in order to prevent overheating of the motor.
 - Operation of a LSx servo motor with higher d.c. link direct voltage, as specified in the data sheet, is only permissible if a written approval by the projecting engineer has been obtained.
-

Example with LSH-097-2-30-320

In this exemplary application a torque of 4 Nm at a speed of 6000 min⁻¹ is required over a period of 10 s.

Selected motor: The motor is chosen on basis of the approximation calculus. It is operated in combination with a three-phase servo controller CDx34.xxx (400 V output voltage).

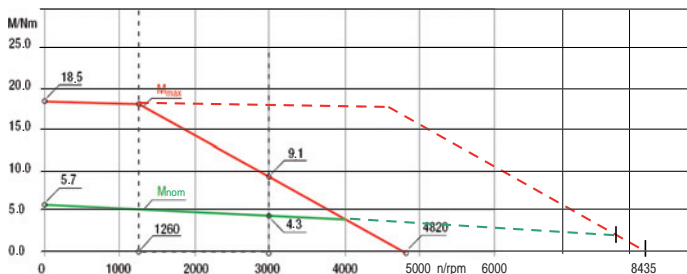
Approximation calculus: The electrically possible rotary speed increases approximately proportional to the voltage reserve:

$$560 \text{ V} / 320 \text{ V} = 1.75$$

When using a 320 V motor on a 560 V d.c.-link controller, one theoretically achieves a by factor 1.75 higher motor speed.

The maximum characteristic is extended to the right by factor 1.75: (4820 x 1.75 = 8435 min⁻¹).

The green S1 characteristic is extended while maintaining its inclination:



This increase applies only approximately, because the iron losses, resistive losses and inductive losses in the motor were severely neglected. The actual increase of the speed characteristic turns out to be lower. Due to the high rotating field frequency a considerable increase of the reactance voltage proportion can be expected, especially on the low-speed LSH motor. This reactance proportion is lost for the voltage reserve and thus also for the available torque.



Attention:

- the max. permissible mechanical speed of the motor must not be exceeded.
- the max. possible rotating field frequency of the servo controller must not be exceeded.
- The thermal design of the motor must be checked in the application.

First arithmetical control:

Selected motor: LSH-097-2-30-320

Data of the synchronized servo motor LSH-097 ... can be taken from this chapter.

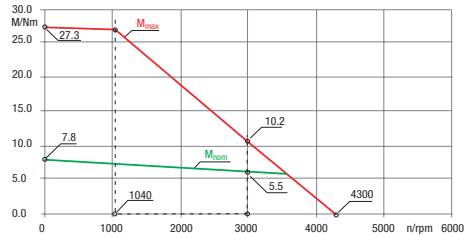


Fig. 2.14 Characteristic LSH-097-2-30-320

Calculation of the maximum rotating field frequency:

$$f_{\max} = \frac{n_{\max} \cdot p}{60} = \frac{6000 \text{ min}^{-1} \cdot 5}{60} = 500 \text{ Hz}$$

Calculation of the maximum motor current at 6000 min⁻¹

$$I_{\max,6} = I_n \cdot \frac{M_{\max,6}}{M_n} = 6 \cdot 6 \text{ A} \cdot \frac{4 \text{ Nm}}{4,4 \text{ Nm}} = 6,14 \text{ A}$$

Calculation of the maximum motor voltage at 6000 min⁻¹

$$U_{\max,6} = K_E \cdot n_{\max,6} = \frac{41,5 \text{ V}}{1000 \text{ min}^{-1}} \cdot 6000 \text{ min}^{-1} = 249 \text{ V}$$

Calculation of the maximum voltage reserve

$$U_{\text{res}} [\%] = 100 \cdot \left(\frac{100 \cdot U_{\max,6}}{U_{\max \text{ Regler}}} \right)$$

$$U_{\text{res}} [\%] = 100 \cdot \left(\frac{100 \cdot 249 \text{ V}}{400 \text{ V}} \right) = 37,75 \%$$

A voltage reserve of 15 to 20 % should be available.

Second arithmetical control

Conversion of effective value into phase values:

The phase voltage U_1 is made up of the voltage drops on the stator winding resistance R_{1ph} and the stator leakage reactance X_{1ph} (the main reactance X_h is neglected) as well as the armature voltage U_p (Counter-EMF).

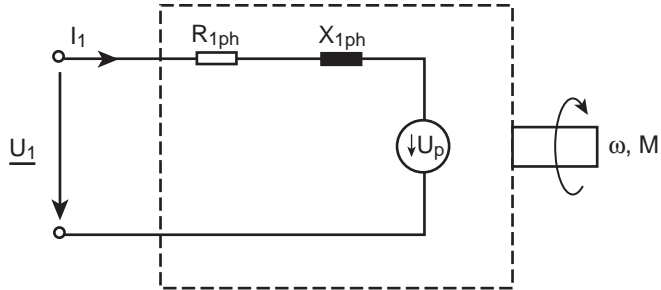
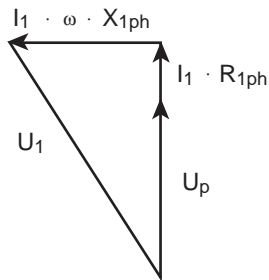


Fig. 2.15 Single-phase substitute diagram for the synchronized machine

The voltage equation is:

$$\underline{U}_1 = (R_{1ph} + j X_{1ph}) \cdot I_1 + U_p$$



Calculation of the stator voltage (Counter-EMF):

$$U_p = \frac{U_{\max.6}}{\sqrt{3}} = \frac{249 \text{ V}}{\sqrt{3}} = 144 \text{ V}$$

Calculation of the resistive voltage drop:

$$\begin{aligned}
 U_{R1ph} &= I_{\max.6} \cdot R_{1ph} = I_{\max.6} \cdot \frac{R_{2ph}}{2} \cdot 1,5^{1)} \\
 &= 6,14 \text{ A} \cdot \frac{0,7 \Omega}{2} \cdot 1,5 = 3,2 \text{ V}
 \end{aligned}$$

1) Supplement factor for hot winding

Since the motors are connected in Y-mode, the $J_{\max.6}$ equals the $J_{\max.6}$ in a single-phase substitute diagram.

Calculation of the inductive voltage drop:

$$\begin{aligned}
 U_{XL1ph} &= X_{L1ph} \cdot I_{\max.6} = 2 \cdot \pi \cdot f_{\max} \cdot I_{\max} \cdot \frac{L_{2ph}}{2} \\
 &= \pi \cdot 500 \text{ Hz} \cdot 6,14 \text{ A} \cdot 6,9 \text{ mH} = 68 \text{ V}
 \end{aligned}$$

Calculation of the phase voltage:

$$\begin{aligned}
 U_1 &= \sqrt{(U_p + U_{R1ph})^2 + (U_{XL1ph})^2} \\
 &= \sqrt{(144 + 3,2)^2 + (68 \text{ V})^2} = 162 \text{ V}
 \end{aligned}$$

Calculation of the maximum voltage reserve:

$$U_{ph-ph} = U_{uv} = U_{vw} = U_{uw} = U_1 \cdot \sqrt{3} = 281 \text{ V}$$

1) Servo motors are connected in Y-mode

$$\begin{aligned}
 U_{res} [\%] &= 100 - \left(\frac{100 \cdot U_1}{U_{\max. Regler}} \right) \\
 &= 100 - \left(\frac{100 \cdot 281 \text{ V}}{400 \text{ V}} \right) = 29,75 \%
 \end{aligned}$$

A voltage reserve of 15 to 20% should be available.

The calculation confirms that even at 15 % mains undervoltage the required DC link voltage is sufficient to operate the motor at the desired motor current at a speed of 6000 rpm.

This method of translating the motor characteristic can also be used to deploy a "smaller" servocontroller at lower speeds.

If, for example, a motor is required with a rated speed of approximately 1500 rpm, a 560 V motor (3000 rpm rated speed) can be operated on a single-phase fed servocontroller (in a 320 V DC system). This saves motor current and thus drive controller cost.

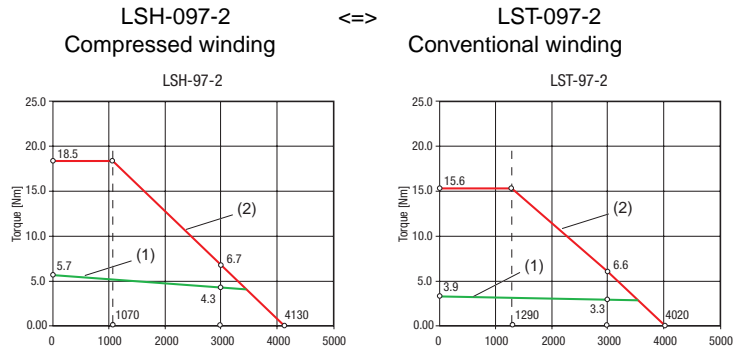
Comparison of the different winding technologies of synchronous servomotors

The new winding technology of servomotors – the so-called compressed winding – offers a number of advantages: Compact design, low-cost manufacture, and extremely high torque.

Nevertheless, conventional winding technology – the s-called distributed winding – still has a justified existence.

Based on the example of the LSH and LST series, the technical features and respective advantages of the different winding technologies can be demonstrated:

	Compressed winding technology	Conventional "distributed" winding technology
Motor series	LSH	LST
Design	10-pole rotor (except: LSH-050: 6-pole)	6-pole design
Rated frequency	250 Hz/3000 rpm	150 Hz/3000 rpm
Smooth running on servocontroller CDE/CDD	Very good	Very good
Sizes (edge dimensions)	LSH-050 to LSH-127	LST-037 to LST-220
Moment of inertia	approx. 60 % of LST motor	100 %
Value for money	Very good	Good



- 1) S1 characteristic (thermally permissible continuous torque)
- 2) Short-time possible maximum torque

Figure 2.16 Comparison of torque characteristics based on the example of the LSH-097-2 (same size)

The comparison of the two characteristics clearly shows the higher torques of the LSH motor compared to the LST motor. The standstill torque and the rated torque of the LSH are much higher than that of the LST. Moreover, the magnets of the LSH motor permit higher maximum torques than those of the LST motor.

Despite all these advantages, the LSH motor cannot cover every application:

Limitations of the LSH motor/Strengths of the LST motor

Due to the high-pole design of the LSH motor above size 074 (10-pole), it has a rated frequency of 250Hz from a rated speed as low as 3.000 rpm. Conversely, the LST motor is of 6-pole design across all sizes, and so has a rated frequency of just 150Hz at the same speed.

As the motor frequency increases, the core loss in the motor also increases disproportionately.

The high motor frequencies of the LSH motor have a particular impact in the case of special windings with higher rated speeds of up to 6.000 rpm.



Consequently, the principle with regard to motor sizes above 074 is: At rated speeds of 4.500 rpm or higher the LST motor should be used.

Where adaptation of the moment of inertia is required, the LST motor is able to attain better control properties than the more dynamic LSH motor.

If high dynamics are required, the LSH motor scores highly. The high power density of the LSH motor also makes it a convincing choice in standard applications. Furthermore, the LSH motor also wins in terms of price and owing to its compact lengths.

As the comparison shows, the application is ultimately the decisive factor in selecting the right winding technology.

2.3 Selecting special three-phase AC motors

Special motors are operated mainly on c-line drive controllers CDA3000 and CDA3000HF. The following table sets out the typical areas of application of the drive solution with special motors.

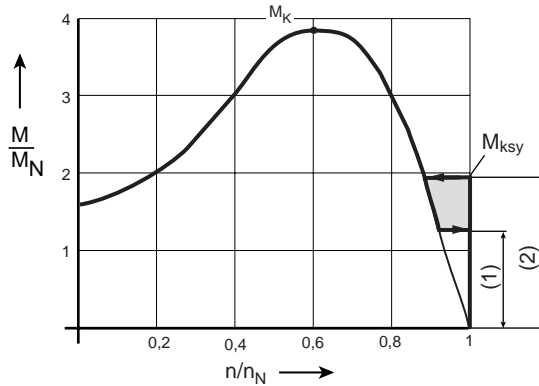
Typical areas of application of special three-phase AC motors

Motor type	Working principle	Application
Synchronous motor with damper cage	Synchronous	In the textile industry for: spoolers, viscose pumps, galette drives, roller drives etc. Further areas of application are in the glass and paper industry as winding drives, etc.
Reluctance motor	Asynchronous-synchronous	In the textile industry for: spoolers, viscose pumps, galette drives, roller drives etc. Further areas of application are in drafting equipment and for synchronous running of two axles.
High-frequency motor	Synchronous-asynchronous	In the timber processing industry as the main drive. Further areas of application are grinding and milling spindles, centrifuges, vacuum pumps and winders.

Table 2.15 Areas of application of special motors

2.3.1 Characteristic values of reluctance motors

Typical torque characteristic



(1) Pull-in to synchronism $M_{sy} \approx 1,2 \cdot M_N$

(2) Pull-out of synchronism $M_{ksy} \approx 1,6\text{ to }1,8 \cdot M_N$

$$M_K \approx 3,5 \cdot M_N$$

Figure 2.17 Typical torque characteristic of a reluctance motor in mains operation



The motor may only be run to accelerate in asynchronous mode.
If asynchronous mode is run for longer the motor will be destroyed.

Torque as a function of load angle

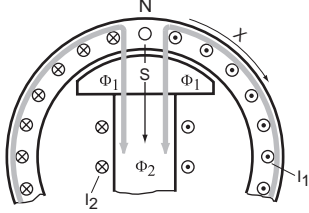
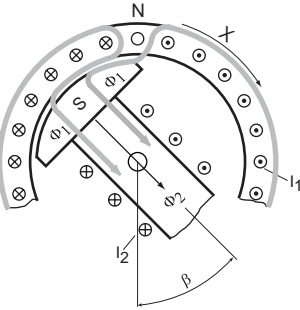
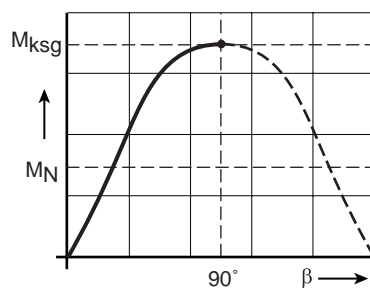
Idling of the reluctance/synchronous motor	Loading of the reluctance/synchronous motor
	
<p>The stator field Φ_1 with the field system of the rotor Φ_2 represents a fixed magnetic adhesion.</p>	<p>As the load on the shaft increases, the rotor displacement angle/load angle increases steadily. The speed remains synchronous.</p>
<p>X Direction of rotation β Load angle</p>	

Table 2.16 Torque as a function of rotor displacement angle b (load angle)



β Referred to the motor shaft		
Pole pairs	β_{MN} typical	β_{Mksg}
1	20°	45°
2	10°	22.5°
3	6.75°	15°
4	5°	11.25°

Table 2.17 Internal torque as a function of load angle

Internal torque (M_i) $M_i = k \cdot \Phi \cdot i \cdot \sin\beta$



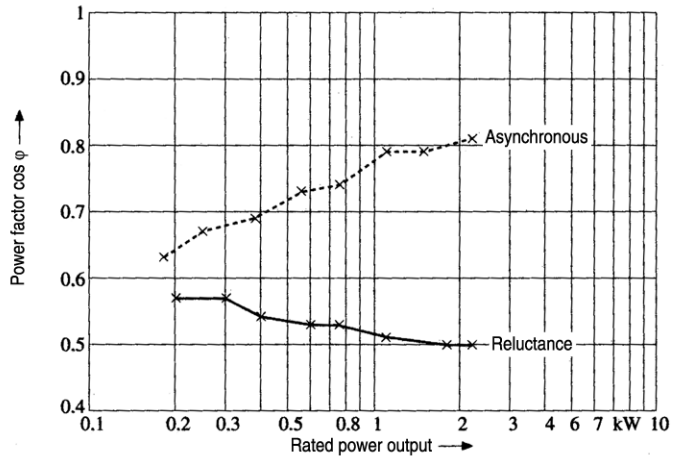


Figure 2.18 Data comparison of reluctance design against asynchronous design of a series of four-pole motors in a 50 Hz system - Power factor

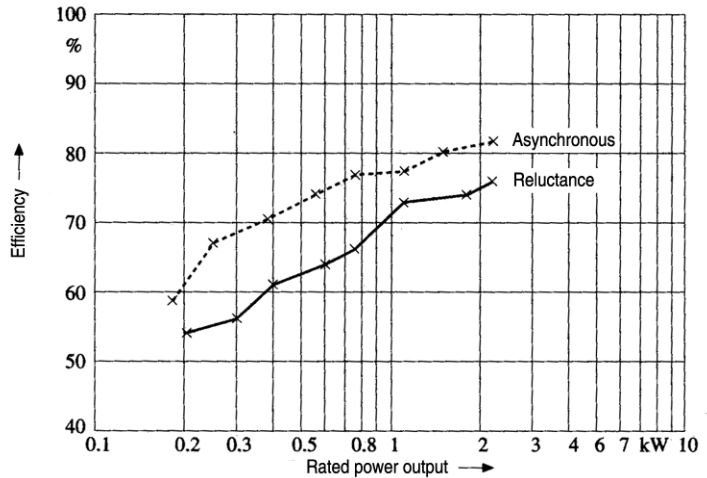


Figure 2.19 Data comparison of reluctance design against asynchronous design of a series of four-pole motors in a 50 Hz system - Efficiency

Project planning notes

A 3-phase AC reluctance motor is a special motor which must be tested anew prior to every production deployment. Depending on the situation, smooth running, heat, noise or vibration problems may occur. The following table presents a listing of key points which may need to be considered.

Detailed information can only be provided by the manufacturer of the reluctance motor, however.

Subject	Project planning notes
<p style="text-align: center;">Motor design</p>	<p>See manufacturer's data sheet</p> <p>Tips:</p> <ul style="list-style-type: none"> • Winding always in star configuration (high inductance) • Inquiries for motors for S3 to S6 operation must usually be submitted separately • Motor protection only possible via PTC or Klixon • High tendency to vibrate, especially < 25Hz
<p style="text-align: center;">Drive controller configuration</p>	<p>In static operation</p> <ul style="list-style-type: none"> • I-drive controller $\approx 1.2 \cdot I_N$ motor <p>In dynamic operation</p> <ul style="list-style-type: none"> • I-drive controller $\approx 1.8 \cdot I_N$ motor • Shut down the slip compensation, load compensation and V/F characteristic adaptation software functions • V/F characteristic with at least 3-6 fully programmable interpolation points • At frequencies > 150 Hz an additional filter must very often be inserted in the motor cable • The max. output frequency must not be higher than FN (frequency nominal point). • When motors are connected up a very high short-circuit current flows (typically up to 30-40 times I_N).

Table 2.18 Project planning notes for drive system with reluctance motors

2.3.2 Characteristic values of synchronous motors with damper cage

Synchronous motor with salient-pole rotor

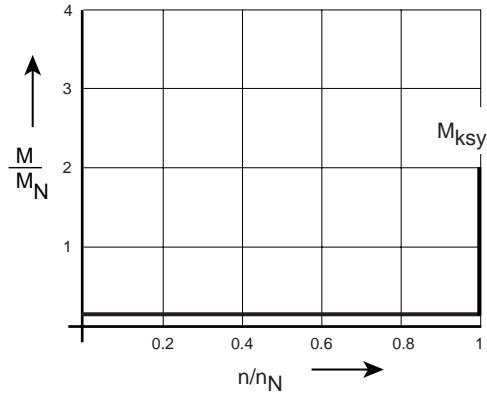
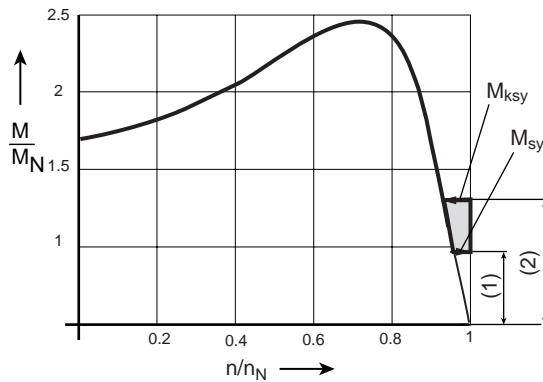


Figure 2.20 Typical torque characteristic of a synchronous motor with salient-pole rotor

Synchronous motor with cage winding and permanent magnets



- (1) Pull-in to synchronism $v_{sy} \approx 0,9 \cdot M_N$
- (2) Pull-out of synchronism $v_{kSY} \approx 1,35 \cdot M_N$ (corresponding to VDE 0530)

Figure 2.21 Typical startup characteristic of a permanent magnet excited synchronous motor with cage winding and permanent magnets

Torque as a function of load angle

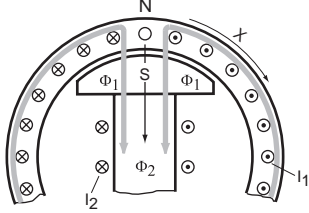
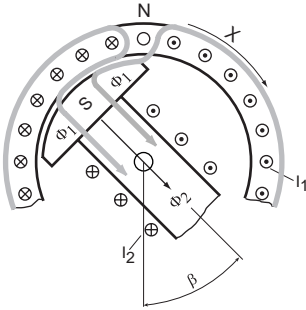
Idling of the reluctance/synchronous motor	Loading of the reluctance/synchronous motor
	
<p>The stator field Φ_1 with the field system of the rotor Φ_2 represents a fixed magnetic adhesion.</p>	<p>As the load on the shaft increases, the rotor displacement angle/load angle increases steadily. The speed remains synchronous.</p>
<p>X Direction of rotation β Load angle</p>	

Table 2.19 Torque as a function of rotor displacement angle b (load angle)

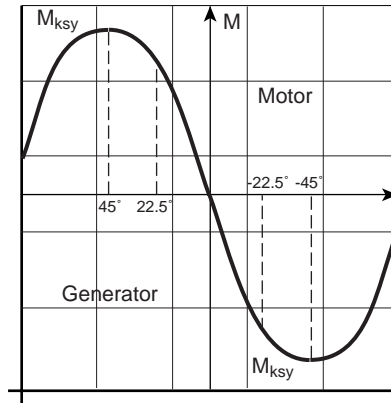


Figure 2.22 Torque as a function of load angle in the synchronous machine with salient-pole rotor

Project planning notes

A synchronous motor, too, is a special motor which must be tested anew prior to every production deployment. Depending on the situation, smooth running, heat, noise or vibration problems may occur. The following table presents a listing of key points which may need to be considered.

Subject	Project planning notes
Motor design	<p>For precise data refer to the manufacturer's data specification booklet</p> <p>Tips:</p> <ul style="list-style-type: none"> • Synchronous motors with cage winding can be run on the mains and on the drive controller. • The synchronous breakdown torque M_{kSy} is approx. $1.35 \times M_N$. If a higher breakdown torque is required (e.g. 1.6 times), a higher-powered motor must be chosen. • The external moment of inertia specified by the manufacturer must not be exceeded, otherwise the motor will not be able to generate the acceleration torque required for synchronization. • At low frequencies the idle current may be higher than the load current. • Motor protection only possible via PTC • High tendency to vibrate
Drive controller configuration	<p>In static operation with manipulating range $\leq 1:5$ (20-100 Hz)</p> <ul style="list-style-type: none"> • I-Drive controller $\sim I_N$ Motor <p>In static operation with manipulating range $\leq 1:5$ (20-100 Hz)</p> <ul style="list-style-type: none"> • I-Drive controller $\sim 1.2 \times I_N$ Motor <p>With group drive</p> <ul style="list-style-type: none"> • For project planning notes for multi-motor operation refer to section 3.4.7. The startup currents for connection of the motor to max. frequency may be 30 times the rated motor current. • V/F characteristic with at least three programmable interpolation points • Shut down the slip compensation, load compensation and V/F characteristic adaptation software functions <p>For rapid synchronization the motor should be run in the frequency range to 50 Hz with current injection. In individual applications it will be necessary to stop the acceleration process for 10 s at 5 Hz to allow the motor time to switch to synchronous mode.</p>

Table 2.20 Project planning notes for permanent magnet excited synchronous motors with cage winding for asynchronous self-starting.

Detailed information can only be provided by the manufacturer of the synchronous motor, however.

2.3.3 Characteristic values of high-frequency motors

Typical torque characteristic of a high-frequency spindle

Beispiel: $P = 1.4 \text{ kW}$, $I_N = 7 \text{ A}$, $U = 220 \text{ V}$

$n = 5.000\text{-}50.000 \text{ rpm}$

Application: Drilling, milling, grinding, engraving

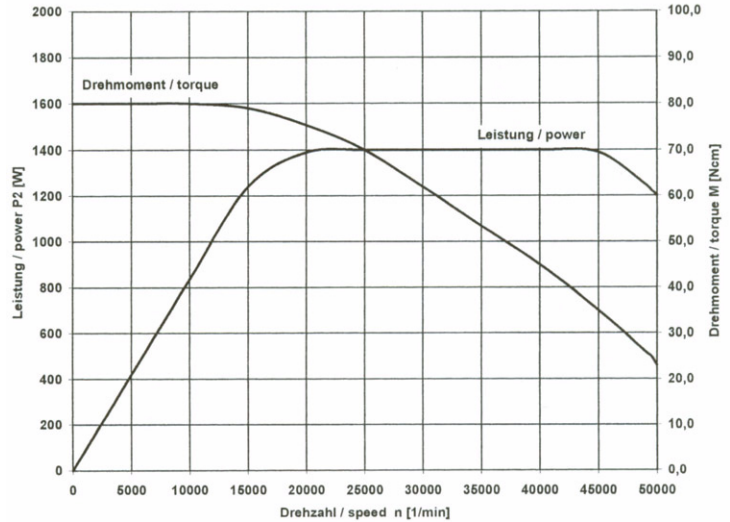


Figure 2.23 Torque/power characteristic of an asynchronous high-frequency spindle

Project planning notes:

Relate to standard motors, a high-frequency motor is a special motor with specific properties. The asynchronous motors domain typical of this sector is increasingly being broken into in the field of regulated high-frequency motors by permanently regulated synchronous motors.

High-frequency motors must be tested in detail prior to any production deployment. This requires compliance with the technical specifications given on the manufacturer's data sheet.

Depending on manufacturer and application, smooth running, heat, noise or vibration problems may occur. The following table provides hints as to what key points need to be considered and indicates the engineering (project planning) diversity.

Subject	Project planning notes						
Motor design	<p>Precondition: Precise manufacturer's data from motor data sheet</p> <p>Tips:</p> <ul style="list-style-type: none"> • The torque depends heavily on the speed. • Motor protection by DIN PTC or thermal circuit-breaker require. • Motor protection for special applications with temperature sensor KTY81-130 possible. • Frequently special measures are needed to cool the motor, e.g. <ul style="list-style-type: none"> – Water cooling via clamp block – Direct water cooling – Oil cooling – Convection cooling at reduced output. • Typically there is a high torque requirement in the lower basic manipulating range and a low torque requirement in nominal operation. • In the case of high-frequency spindles a field-weakening range of 1:10 referred to the basic manipulating range is possible. <p>Attention: This is not achievable with regulated drives. Max. manipulating range 1:2.</p> <ul style="list-style-type: none"> • The project planning phase for a high-frequency motor should take into account necessary filters/motor chokes when rating the voltage. <p>Typical voltage drop of filter/motor choke:</p> <table border="1" data-bbox="539 879 782 967"> <thead> <tr> <th>System</th> <th>Voltage drop</th> </tr> </thead> <tbody> <tr> <td>400 V AC</td> <td>60 - 80 V</td> </tr> <tr> <td>230 V AC</td> <td>40 - 60 V</td> </tr> </tbody> </table>	System	Voltage drop	400 V AC	60 - 80 V	230 V AC	40 - 60 V
System	Voltage drop						
400 V AC	60 - 80 V						
230 V AC	40 - 60 V						
Encoder system configuration	<p>Open-loop controlled system with drive controller GDA3000</p> <ul style="list-style-type: none"> • Evaluation of square pulses with levels based on specification of the digital control inputs (HTL encoder) • Simple standstill monitoring: Any number of pulses per revolution • Out-of-sync monitoring for permanently excited synchronous motors: 1 pulse per revolution 						

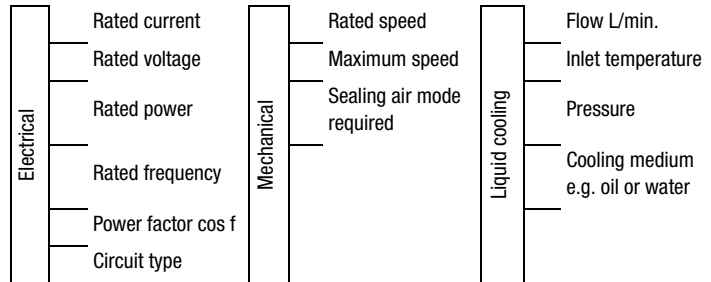
Subject	Project planning notes
Encoder system configuration	<p>Closed-loop controlled system with controller</p> <ul style="list-style-type: none"> • Evaluation of: <ul style="list-style-type: none"> – Resolver – sin/cos encoder – Hall sensors with encoder signals based on specification of the controller encoder inputs <p>Attention: The signal shape and size may need to be adapted by way of an external electronic circuit. High cost - only feasible for large production volumes.</p>
Drive controller configuration	<ul style="list-style-type: none"> • High-frequency motors are generally very low-inductive, so the lack of low-pass filtering means no high frequencies are damped. The rotor time constant of such motors is very small compared to standard motors or servomotors. • Heat-up <p>Compact design and low inductance result in substantial heat-up of the motors. This can be reduced by motor chokes or sine filters.</p> <ul style="list-style-type: none"> – Additional inductance in the form of a motor choke "smooths" the motor current. High frequency components of the current (harmonics) are damped to a greater degree. – An optimum sinusoidal current can be achieved with sine filters (e.g. LC filters). High frequency components of the current and the voltage are filtered out by this low-pass filter. The motor losses are minimized and so heat-up is reduced. – For high-frequency motors operated at rotation frequencies of >800 Hz a switching frequency of the drive controller power stage of 16 kHz (rated frequency 32 kHz) is recommended. This measure enhances the smooth running of the motor and reduces the heat-up. As the switching frequency increases the output of the drive controller falls however.

Subject	Project planning notes
Drive controller configuration	<ul style="list-style-type: none"> • du/dt filters act as voltage limiters of pulses of the modulated output voltage. <ul style="list-style-type: none"> – They limit the rate of rise of the PWM voltage and protect the motor winding. – Very minor low-pass filtering, i.e. virtually no reduction in motor heat-up. • Open-loop controlled system <ul style="list-style-type: none"> – V/F characteristic with at least 3-6 fully programmable interpolation points. – Follow the rules for multi-motor operation. – Allow for the voltage drop as a function of the filter inductance, the frequency and the current. The voltage drop results in a flux reduction and a reduced motor torque. – High idle currents result in substantial heat-up, and should be reduced where possible by lowering the voltage at idle. • Closed-loop controlled system <ul style="list-style-type: none"> – Sine filters (LC filters) should be included in the control system. – Motor chokes can be added to the leakage inductance of the motor if not included as separate controlled systems. – The voltage drop is registered by the filter/choke controlled system and taken into account for regulation of the motor.

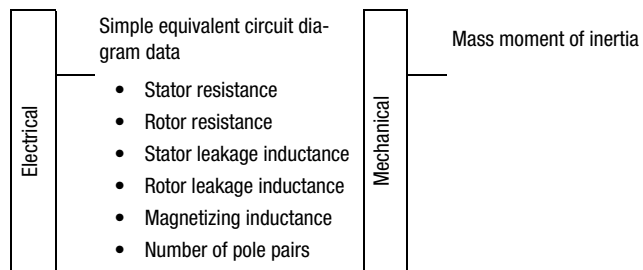
The following data are required for the commissioning and tests:

Air- and liquid-cooled high-frequency motors

- Closed and open loop-controlled systems



- Additionally only in closed-loop systems



The following conditions must additionally be met in advance for tests carried out at LUST in order to ensure rapid processing:

- Motor connection with special connector without terminal board?
 - Supply mating plug with open cable end
- Sealing air mode for bearing lubrication?
 - Indication of air pressure required
 - Supply oiler unit with connecting hoses
 - Supply matching connecting hoses with open end
- Water cooling required?
 - Supply matching connecting hoses with open end
 - Specify max. water pressure and flow
- Bearing of high-frequency motor already run-in?
 - Indication of run-in play essential
 - Tool chuck for high-frequency spindles required

2.4 Selecting encoders

Closed-loop drive systems require an encoder to measure the position and speed. Motors with magnetic feed direction, such as synchronous motors, additionally require the absolute angle of the rotor orientation after system startup.

Fundamentally, all encoders detailed in this section deliver position information from which the speed is calculated in the drive controller by various mathematical methods.



-
- This section deals only with rotary encoder systems. The properties and measuring methods of linear encoder systems should be seen as analogous to their rotary "brothers and sisters".
 - Only encoders which can be evaluated with the c-line DRIVES controllers are covered.
-

2.4.1 Overview of types

Principle of function

In this section the encoder systems suitable for the c-line DRIVES are detailed in the following points:

- Signal type, signal tracks and signal level
- Evaluation methods for determining position and speed in the drive controller

Incremental encoders

Incremental encoders convert the mechanical rotation speed into a number of pulses.

In the photoelectric sampling method a disk (glass, metal or plastic) is supported on a pivot bearing between an LED and a receiver unit. A line grid is plotted on the disk. The light emitted by the LED is modulated through the orifice and the line grid and strikes the receiver unit, which delivers a signal proportional to the brightness. When the disk is rotated this signal has a virtually sinusoidal shape. The number of lines determines the resolution, i.e. the measuring points within a revolution.

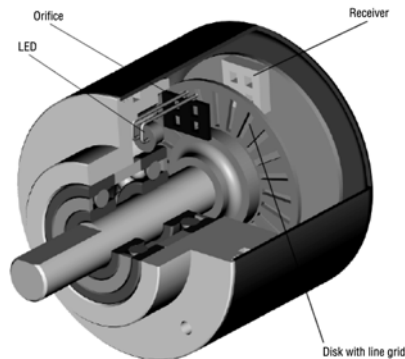


Figure 2.24 Design of an incremental encoder (source: Kübler)

The sinusoidal signals are processed in the encoder electronics. The c-line DRIVES drive controllers require digital (square) or analog (sinusoidal) signals depending on encoder input. Consequently, the signals are conditioned accordingly before leaving the encoder and delivered by various output circuits depending on area of application.

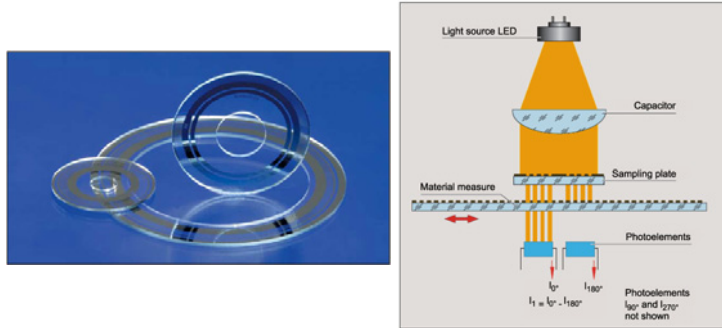


Figure 2.25 Circular graduations and photoelectric measuring principle for incremental encoders (source: Heidenhain)

Some incremental encoders nowadays use different sampling methods. Many have a permanently magnetized graduation as the material measure, which is sampled via magneto-resistive sensors. In the inductive sampling principle copper/nickel-based graduation structures are used. A high-frequency signal is here modulated in its amplitude and phase angle by the moved graduation structures.

TTL and HTL encoders

Encoders with TTL or HTL output signals deliver square signals. They have two tracks and a zero-pulse track. The two electrically 90° offset sensors in the encoder deliver two sequences of pulses on tracks A and B. Track A has a 90° advance over B in clockwise rotation looking at the motor shaft (A-side). The direction of rotation of the motor is determined by way of this phase ratio. The zero pulse (one pulse per revolution) is recorded by a third light barrier in the encoder and made available as a reference signal on track R.

In TTL encoders tracks A+, B+ and R+ are inverted in the encoder and made available as inverted signals on tracks A-, B- and R-. The transfer runs via an RS422 interface (see section 2.4.4, "Interfaces").

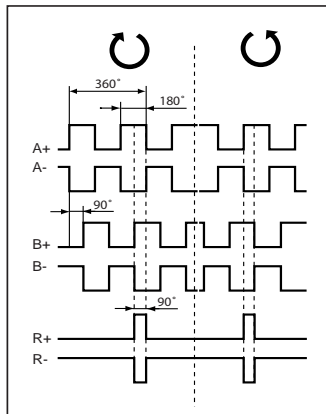


Figure 2.26 TTL signals with a zero track and inverted signals (RS422)
HTL signals with a zero track but without inverted signals

TTL encoders require a voltage supply of $5 V_{DC} \pm 5\%$. To safeguard this tolerance additional sensor cables are required (see section 2.4.4, "Interfaces").

HTL encoders are evaluated in the c-line DRIVES without the inverted tracks; no differential signal evaluation is possible. The HTL signals are therefore susceptible to interference on the line, which may have unfavourable effects on the EMC behaviour.

The HTL signal levels are $U_{Low} \leq 3 V$ and $U_{High} \geq U_B$ minus 3.5 V. U_B is the supply voltage of the encoder. It may be in the range $10...30 V_{DC}$; for the drive controller common voltages are $24 V_{DC} \pm 20\%$. HTL encoders require no adjustment of the supply voltage and thus also no sensor cables. As a result of the large $U_{High} - U_{Low}$ voltage deviation the HTL encoders have a high current consumption. This must be taken into account in configuring the encoder supply.

The basis for determining position with TTL and HTL encoders is conversion of the square signals into count pulses. As shown in Figure 2.27, each edge change generates a count pulse. This enables quadruple evaluation of the position, as four count pulses are generated in each period of a square oscillation. That means the resolution of the position is increased by a factor of 4 (2 bits). To incorporate a change in direction of rotation, the count pulses are fed to an Up/Down counter.

The number of count pulses is thus calculated from the difference between Up and Down pulses.

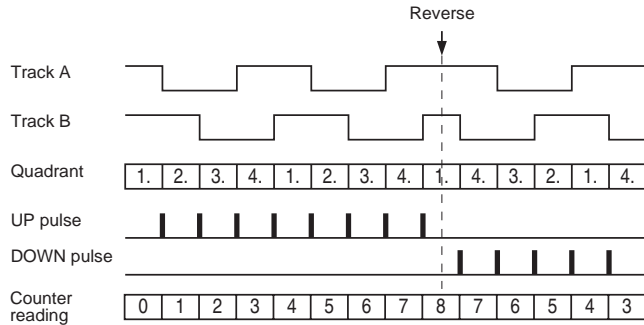


Figure 2.27 Quadruple evaluation with TTL and HTL incremental encoders

The maximum angle resolution, or the smallest angle stepwidth $\Delta\varepsilon$ as a function of the number of lines per revolution of the encoder and the position ε are thus calculated according to:

$$\Delta\varepsilon = \frac{360^\circ}{\text{Lines per rev} \times 4} \quad \varepsilon = \sum \text{pulses} \times \Delta\varepsilon$$

Example: The position resolution of an encoder with 1024 lines per revolution ($1024 = 2^{10}$ corresponding to 10 bits) is increased by the quadruple evaluation to 12 bits. This corresponds to an angle resolution of $\Delta\varepsilon = 360^\circ/2^{12} = 0.088^\circ = 5$ angle minutes.

The speed is calculated from the change in position and the resulting pulse counter change within the sampling period of the speed recording T_n . The sampling period T_n of the c-line DRIVES drive controllers is between $125 \mu\text{s}$ (8 kHz) and $250 \mu\text{s}$ (4 kHz). To attain the most accurate possible speed calculation, a method combining pulse counting and pulse duration measurement is used.

- **Pulse count**
In the pulse count method the speed is calculated from the sum of the pulses per sampling period T_n . This method is optimal for high speeds, as in that range large numbers of pulses occur in a sampling period.

$$n[\text{rpm}] = \frac{\sum \text{pulses}}{T_n \times 4 \times \text{Lines per rev}} \times 60$$

Figure 2.28 Pulse count

At lower speeds this method is unsuitable, as they can no longer be represented. They are shown as 0 rpm.

Example of the lowest speed able to be represented by the pulse method:

$$\text{Encoder lines per rev} = 1024$$

$$T_n = 250 \mu\text{s}$$

$$n_{\min}[\text{rpm}] = \frac{1}{250 \mu\text{s} \times 4096} \times 60\text{s} \approx 59 \text{ rpm}$$

- Pulse duration measurement

In the pulse duration method the speed is calculated from the time t in which a pulse has occurred. This method is optimal for low speeds, as the time measurement it provides is very accurate.

At high speeds this method is unsuitable, as the time measurement is limited by the resolution of the electronics time measurement.

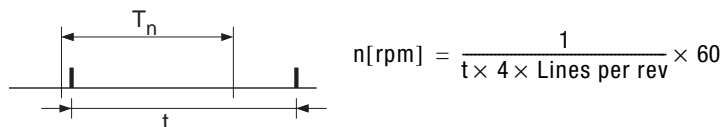
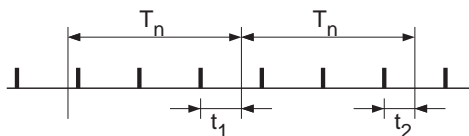


Figure 2.29 Pulse duration measurement

- Combined method

In the combined method the precise time in which the pulses occurred is determined on the basis of the sampling period.

The full speed range is thus optimally determined.



$$n[\text{rpm}] = \frac{\sum \text{pulses}}{(1+k)T_n + t_1 - t_2} \times \frac{60}{4 \times \text{Lines per rev}}$$

Figure 2.30 Combined method

If no pulse occurs in a sampling period T_n , no new speed is calculated, only the sampling period, or the factor k , is increased by 1. In the c-line DRIVES drive controllers the measuring time is extended to 5 ms. If no pulse occurs within this time, the speed is set to 0 rpm. By increasing the measuring time, the representable speed range can be extended beyond the scope of mere pulse counting to cover low speeds.

Example of the lowest speed able to be represented by the combined method:

Encoder lines per rev = 1024

$$n_{\min} [\text{rpm}] = \frac{1}{0.005 \text{ s}} \times \frac{60 \text{ s}}{4 \times 1024} = 2.93 \text{ rpm}$$

Increasing the sampling period also means increasing the sampling time of the speed control loop, which reduces the permissible controller gain and thus the rigidity on the motor shaft. The reduced speed controller gain at 0 rpm can be set as a percentage of the nominal gain on the c-line DRIVES. Above the speed at which at least 1 pulse per sampling period no longer occurs (calculable with the equation from Figure 2.28), the gain is reduced in linear mode from the nominal gain down to the gain at 0 rpm.

The calculated actual speed is smoothed to compensate for the jitter effect of the incremental encoder by means of a filter. The jitter effect stems from a fluctuation in the edge pulse positions of the two encoder tracks.

sin/cos encoders (SinCos)

Senders with high-resolution sin/cos signals, so-called sin/cos encoders, deliver two 90° offset sinusoidal signals. The number of sine curves (corresponding to the number of pulses), the zero crossings and the amplitudes (arc tangent) are evaluated. This enables the speed to be determined at a very high resolution. This encoder is suitable for drives operated with large manipulating ranges which must also run at low speeds without bucking.

The sin/cos encoders have two tracks and a zero-pulse track; inversion then produces six tracks. The two 90° offset sinusoidal signals are on tracks A and B. As the zero pulse one sine half-wave per revolution is made available on track R. Tracks A+, B+ and R+ are inverted in the encoder and made available as inverted signals on tracks A-, B- and R-.

The transfer runs via an RS422 interface (see section 2.4.4, "Interfaces").

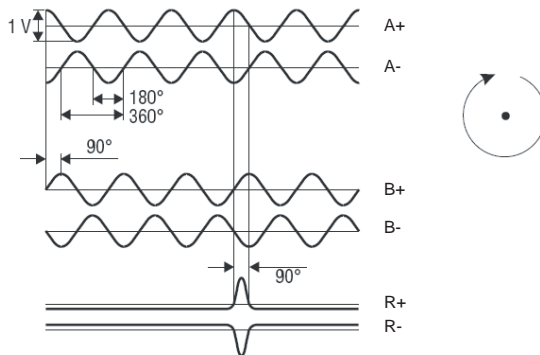


Figure 2.31 *sin/cos signals with zero track and inverted signals (RS-422)*

The sin/cos signals are superimposed on a DC voltage of 2.5 V. The peak-to-peak voltage is $U_{SS} = 1 \text{ V}$. This avoids zero crossings in signal transmission. sin/cos encoders require a voltage supply of $5 V_{DC} \pm 5 \%$. To safeguard this tolerance additional sensor cables are required (see section 2.4.4, "Interfaces").

The sin/cos encoders are evaluated in a similar way to the TTL and HTL encoders. It is, however, additionally possible to evaluate the analog signals in order to improve the position resolution.

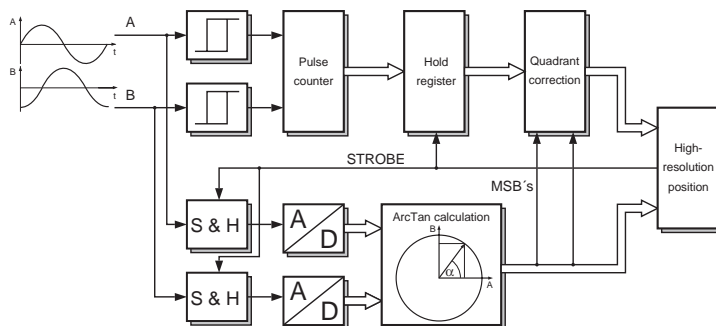


Figure 2.32 *Evaluation of sin/cos encoders*

The sinusoidal signals are pulse-formed and the pulses then counted as in the case of the TTL and HTL encoders.

A second channel records the analog signals with analog/digital converters. The position within a quadrant (one quarter) of the sine oscillation is calculated by way of the arc tangent

$$\alpha = \operatorname{atan} \frac{\text{Track B}}{\text{Track A}}$$

function. For this position to converge with that of the pulse count within a sine oscillation, the two signal paths must be sampled simultaneously. Signal propagation times may result in a shift of +/-1 pulse here, though this is corrected by a quadrant correction.

Finally the position from the pulse count is linked to that from the arc tangent calculation to form a high-resolution position.

Example with a sin/cos encoder with 1024 lines and an analog/digital converter with 12-bit resolution:

- 12-bit position resolution by pulse count with quadruple evaluation
- 12-bit position resolution within a sine oscillation
- Total resolution of 24 bits in a revolution. This corresponds to an angle resolution of $\Delta\varepsilon = 360^\circ/2^{24} = 0.000002^\circ = 0.08$ angle seconds.

The angular accuracy of self-supporting sin/cos encoders is usually 20 angle seconds, corresponding to a position resolution of about 16 bits per revolution. The resolution beyond this (in the example 24 bits) is used merely to calculate the speed. The high resolution ensures that during a sampling period T_n of the speed recording a position change always occurs. The speed is thus calculated from the position change per sampling period T_n .

$$n = \frac{\varepsilon_k - \varepsilon_{k-1}}{T_n}$$

Absolute encoders

Absolute encoders are required wherever absolute position information is required directly after power-up. Among others, this may be in the case of

- synchronous motors to determine the rotor position or
- machines which permit no referencing movement prior to startup.

In absolute encoders a distinction is made between single- and multi-turn encoders.

- Single-turn encoders deliver absolute position information within one revolution after power-up.
- Multi-turn encoders additionally provide an absolute position over multiple revolutions.

The single-turn encoders have as their material measure an index disk made of glass with multiple pitch/code tracks with grey code. Each angle position is assigned a unique code pattern. With this code pattern the

absolute position of the motor shaft is determined. The special feature of grey code is that on the transition from one resolvable angle increment to the next only one bit changes. The possible read-off error is thus a maximum of 1 bit.

In close proximity to the rotating index disk, one or more sampling plates are arranged, carrying sampling fields assigned to the pitch/code tracks.

Each sampling plate is lit-through by a parallel-aligned light bundle emitted by a light unit comprising an LED and a capacitor. When the index disk is rotated the light stream is modulated and its intensity recorded by photoelements.

Absolute encoders which additionally output incremental signals have four sampling fields assigned to the finest track. The four line grids of the sampling fields are offset to each other by one quarter of the pitch period (pitch period = $360^\circ/\text{number of lines}$).

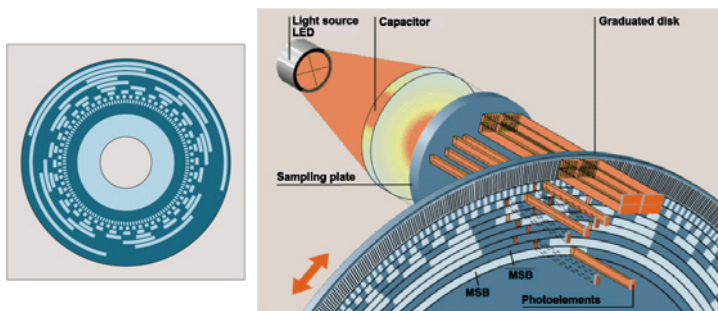


Figure 2.33 Code disk and photoelectric measuring principle for absolute encoders (source: Heidenhain)

Multi-turn encoders have the same design as single-turn encoders to determine the position within a revolution. To generate the multi-turn information a number of different variants exist.

- Additional disk via gearing
The material measure to differentiate the number of revolutions consists of permanently magnetic circular graduations e.g. Heidenhain) or grey-coded glass disks e.g. Stegmann) interconnected by way of a gear. In the first case the sampling is effected by digital Hall sensors, and in the second case by photoelectric sampling.
- Electronic multi-turn generation
Here an electronic solution with magnetic field sensors is applied to create the multi-turn information and store it in a battery-buffered memory (e.g. Kübler).

Encoders with SSI interface

SSI absolute encoders transmit the position via the serial SSI (**S**ynchro-**n**ous **S**erial **I**nterface). This interface permits purely digital serial transfer of the position.

When the absolute position information is being transferred, the absolute position value is transmitted synchronously with a clock (CLOCK) set by the drive controller, beginning with the most significant bit (MSB first). The data word length in this according to the SSI standard is 13 bits for single-turn encoders and 25 bits for multi-turn encoders (13 bits of single-turn information and 12 bits of multi-turn information, i.e. 4096 revolutions).

At idle the clock and data lines are at High level. With the first falling clock edge the current measured value is stored in a parallel/serial converter. The data transfer occurs on the first rising clock edge. After transfer of the complete data word the data output remains at Low level until the encoder is ready for a new measured value retrieval (t_2). If a new data output request (clock) occurs during this time, the data already outputted are outputted again.

If the data output is interrupted (CLOCK = High for $t > t_2$) a new measured value is stored with the next clock edge. The sequencing electronics receives the data on the next rising clock edge.

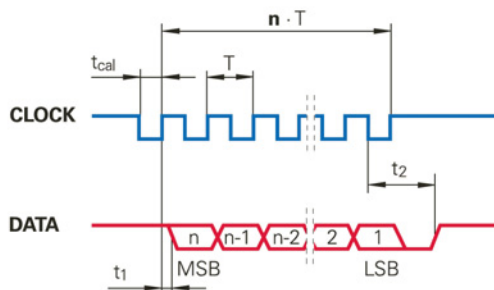


Figure 2.34 Data transfer with the SSI absolute encoder (source: Heidenhain)

The CLOCK+ and DATA+ tracks are inverted in the encoder and made available as inverted signals on the CLOCK and DATA tracks. The transfer runs via an RS422/485 interface (see section 2.4.4, "Interfaces").

SSI absolute encoders require a voltage supply of $5 V_{DC} \pm 5\%$. To safeguard this tolerance additional sensor cables are required (see section 2.4.4, "Sensor cables").

In the various absolute encoders, sinusoidal incremental signals A, B with signal levels of $1 V_{SS}$ are outputted in addition to the serial data transfer. For descriptions of the signal see section 2.4.1, "sin/cos encoders (SinCos)".

In purely absolute encoders - that is, encoders without additional incremental signals - the position is read cyclically with each sampling cycle of the speed recording function via the SSI interface. The sampling period

T_n of the c-line DRIVES drive controllers is between 125 μs (8 kHz) and 250 μs (4 kHz). The maximum angle resolution, or the smallest angle stepwidth $\Delta\epsilon$ as a function of the single-turn resolution of the encoder is calculated according to:

$$\Delta\epsilon = \frac{360^\circ}{2^{\text{Single-turn resolution[Bit]}}}$$

Example: The single-turn resolution of an encoder is 13 bits. This corresponds to an angle resolution of $\Delta\epsilon = 360^\circ/2^{13} = 0.044^\circ = 2$ angle minutes.

The speed is calculated similarly to the pulse count method.

$$n[\text{rpm}] = \frac{\Delta\text{Bit}}{T_n \times 2^{\text{Single-turn resolution[Bit]}}} \times 60$$

$\Delta\text{Bit} = \text{Bit change in sampling period } k$

The lowest speed able to be represented is produced when the position difference in the sampling period is 1 bit. Below that the speed is set = 0 rpm.

Example:

Single-turn resolution = 13 Bit

$T_n = 250 \mu\text{s}$

$$n_{\min} [\text{rpm}] = \frac{1}{250 \mu\text{s} \times 2^{13}} \times 60 \text{ s} \approx 29.3 \text{ rpm}$$

In absolute encoders with additional incremental signals the evaluation takes place as in the conventional sin/cos encoder (see section 2.4.1, "sin/cos encoders (SinCos)"). Consequently, very low speeds are also measurable. The absolute position is usually read only once on system startup, thereby initializing the position calculation. Then only the incremental signals are evaluated.

Encoders with Hiperface interface (RS-485)

Absolute encoders with a Hiperface interface have an asynchronous, half-duplex serial interface (ASI - **A**synchronous **S**erial **I**nterface) to transmit the absolute position. It conforms physically to the EIA RS-485 specification. Encoders with the Hiperface interface are manufactured exclusively by the Stegmann corporation. They are usually executed as built-in encoders for servomotors.

Clock-synchronous transfer of the position is not possible, so for the cyclic position and speed calculation additional sinusoidal incremental signals are transmitted as a process data channel.

The interface to the encoder permits the transfer of diagnostic data from the encoder or also enables drive controller configurations to be stored. These functions are not supported by the c-line DRIVES drive controllers however.

The encoders are supplied with a voltage of 7-12 V. No sensor cables are required, as the voltage is regulated in the encoder itself.

The position and speed are calculated as in the conventional sin/cos encoder (see section 2.4.1, "sin/cos encoders (SinCos)"). Consequently, very low speeds are also measurable. The absolute position is usually read only once on system startup, thereby initializing the position calculation. Then only the incremental signals are evaluated.

Resolver

With the resolver the absolute position of the motor shaft is determined. In principle it is a single-turn absolute encoder. Because it is not self-supporting, the resolver is usually used as a built-in encoder in servomotors.



Figure 2.35 Resolver components (source: LTN)

The resolver consists of a rotor coil and two stator windings at a 90° offset to each other. It works on the principle of the rotary transformer. The resolver additionally has auxiliary windings in the stator and on the rotor respectively to transmit the supply voltage brushlessly to the rotor.

The two rotor windings are electrically interconnected.

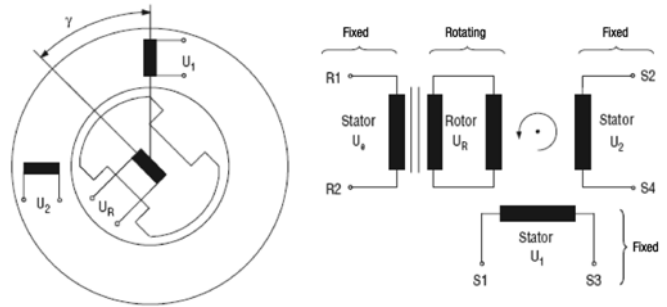


Figure 2.36 Schematic layout and equivalent circuit diagram of the resolver

The resolver is supplied with a constant sinusoidal voltage at U_R (U_{eff} approx 7 V, $f = 8$ kHz). Depending on the position of the rotor, different voltage levels are induced in the stator windings. The voltages U_1 and U_2 on the two stator windings are transformer modulated by the supply voltage and have sinusoidal envelope curves. The two envelope curves are at a 90° electrical offset to each other. The absolute rotor position, speed and direction of rotation are determined from this.

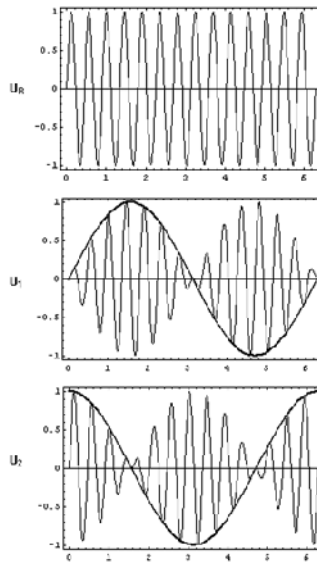


Figure 2.37 Exciter voltage U_R , output voltages U_1 and U_2 of the resolver

The amplitude of the envelope curve is dependent on the effective value and frequency of the supply voltage U_e . Resolvers for the c-line DRIVES require a transmission ratio of 0.5 +/-10 %.

The resolvers are evaluated with the c-line DRIVES similarly to the sin/cos signals of the incremental encoder. This first requires the envelope curve of the amplitude-modulated voltages U_1 and U_2 to be determined. Two variants are currently employed in this:

- Sampling of the amplitude-modulated encoder signals with analog/digital converters synchronous to the peak exciter frequency. The phase shift between excitation and output voltage is corrected by software.
- Demodulation of the amplitude-modulated encoder signals by hardware and sampling of the envelope curve with analog/digital converter. An advantageous factor in this method is that the phase shift between the excitation and output voltages does not need to be taken into account.

The transmission ratio of the resolver is much more tolerant (0.5 +/-20 %). In both above variants therefore the amplitude of the exciter voltage is regulated to utilize the measuring range of the analog/digital converters.

Tolerances of the resolver when assembling electronic circuits create gain, phase and offset errors on the envelope curves. The errors have a serious impact on the measured speed ripple. With the patented GPOC (**G**ain **P**hase **O**ffset **C**orrection) method the errors are minimized and the signal quality thereby improved.

The rotor position is calculated from the ascertained and corrected envelope curves by the arc tangent function. The speed is calculated as in the case of the sin/cos encoder (see section 2.4.1, "sin/cos encoders (SinCos)"). An analog/digital converter with 12-bit resolution in conjunction with quadruple evaluation permits an angle resolution of 14 bits, i.e. a $\Delta\varepsilon = 360^\circ/2^{14} = 0.022^\circ = 1$ angle minute.

2.4.2 Encoder systems for c-line DRIVES

In this section the encoders available from LUST are assigned to the various c-line DRIVES drive controllers and the motors.

Encoder/motor assignment

Encoder/motor combinations need to take account of various criteria:

- Synchronous motors require absolute position information on system startup. Consequently, purely incremental measuring systems cannot be used. Software methods of determining the absolute position (commutation finding) when using incremental encoders are not covered in the following, as the area of application of this solution is restricted.
- Depending on installation environment, a distinction is made between built-in and built-on encoders. The former are built directly into the motor (e.g. in servomotors). Built-on encoders usually require higher protection than built-in encoders (IP65-IP54 as opposed to IP40-IP20). The design of the resolver means it is usually only usable as a built-in encoder.

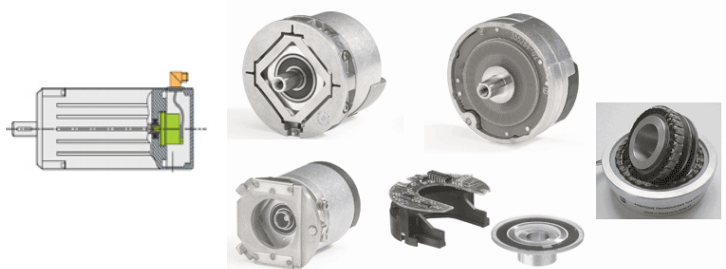


Figure 2.38 Fitting of self-supporting and externally mounted encoders



Figure 2.39 Mounting of externally mounted encoders

The Table 2.21 is derived from these conditions.

	IEC asynchronous motor	Asynchronous servomotor	Synchronous servomotor
HTL incremental encoder	Built-on	Built-in/built-on	-
TTL incremental encoder	Built-on	Built-in/built-on	-
sin/cos incremental encoder	Built-on	Built-in/built-on	-
SSI absolute encoder	Built-on	Built-in/built-on	Built-in/built-on
SSI absolute encoder with sin/cos signals	Built-on	Built-in/built-on	Built-in/built-on
Hiperface absolute encoder	Built-on	Built-in/built-on	Built-in/built-on
Resolver	-	Built-in	Built-in

Table 2.21 Permissible encoder, encoder design and motor combination

Evaluation of encoders with c-line DRIVES

With the c-line DRIVES drive controllers various encoders can be evaluated. The permissible combinations and connection of these encoders are set out in the relevant operation manuals.

	CDA3000	CDB2000	CDE3000	CDD3000	CDE3000	CDF3000
HTL incremental encoder	X ¹⁾		X	X ³⁾		
TTL incremental encoder			X	X	X	X ³⁾
sin/cos incremental encoder				X	X ²⁾	
SSI absolute encoder			X		X	X
SSI absolute encoder with sin/cos signals				X	X ²⁾	
Hiperface absolute encoder				X		
Resolver				X	X	X
1) Evaluation of zero pulse not possible 2) Only possible with special design variant of CDE3000 3) Only usable as master encoder input						

Table 2.22 Permissible encoders depending on drive controller

Accuracies and resolution of encoders

The encoders have differing accuracies. The accuracy in combination with the resolution in the drive controller is the basis for the quality of the position and speed and smooth running. The position and speed resolution is also given in bits. Accordingly, a high resolution in the drive controller is only necessary when the accuracy of the encoder guarantees this.



The accuracies of the encoders vary according to manufacturer, so no generally applicable statements with regard to a type can be made. Consequently, the values given in Table 2.23 relate to the encoders offered and recommended by LUST.

	Typ. absolute accuracy ¹⁾	Typ. repeat accuracy ²⁾	Position resolution in drive controller for position control ³⁾	Position resolution in drive controller for speed calculation ³⁾
HTL incremental encoder (1024 signal periods)	±5'	±1.5'	12 bits = 5' (max. 16 bits)	12 bits = 5'
TTL incremental encoder (1024 signal periods)	±5'	±1.5'	12 bits = 5' (max. 16 bits)	12 bits = 5'
SinCos incremental encoder (2048 signal periods)	±20"	±6"	16 bits = 20" (max. 16 bits. 20 bits CDD3000)	25 bits = 0.04' (max. 30 bits CDD/E3000)
SSI absolute encoder (13 bits per revolution)	±2.5'	±0.5'	13 bits = 2.5' (max. 16 bits)	13 bits = 2.5' (max. 20 bits CDE/B/F3000)
SSI absolute encoder with SinCos signals (2048 signal periods)	±20"	±6"	16 bits = 20" (max. 16 bits. 20 bits CDD3000)	25 bits = 0.04' (max. 30 bits CDD/E3000)
Hiperface absolute encoder (1024 signal periods)	±45"	±7"	16 bits = 20" (max. 20 bits CDD3000)	24 bits = 0.08' (max. 30 bits CDD3000)
Resolver	±10'	±1'	14 bits = 1'	14 bits = 1'
<p>1) Absolute accuracy Variation between actual and measured position. 2) Repeat accuracy: Variation from a repeatedly approached point under identical operating conditions. 3) Maximum values in (): Please pay attention to the maximum resolution of the drive controller when selecting encoders with a higher resolution than indicated here.</p>				

Table 2.23 Typical accuracies of encoders

2.4.3 Project planning

When configuring the machine in project planning the encoder must also be considered. This section in particular provides recommendations and hints on selecting encoders, especially when planning projects involving third-party encoders.

Positioning accuracy

The positioning accuracy is dependent firstly on the properties of the encoder and secondly on the drive controller used.

The accuracy of encoders is essentially dictated by:

- the directional deviations of the radial grid pitch.
- the eccentricity of the index disk on encoders to the bearing.
- the eccentricity of the rotor to the stator on externally mounted resolvers.
- the out-of-true position of the bearing.
- the error due to coupling to a shaft coupling - in the case of encoders with stator couplings this error is within the system accuracy.
- the interpolation variations when processing the measured signals in the built-in interpolation and digitization electronics.

Speed range - maximum signal frequency

The position accuracy of the encoder and its resolution in the drive controller must be defined depending on the desired synchronism,

taking account of the maximum permissible signal frequency of the encoder signals and the maximum signal input frequency of the drive controller (typ. $f_{\max}=500$ kHz).

In the case of incremental encoders this produces the maximum permissible number of lines per revolution Z as a function of the maximum speed n_{\max} of the motor and the maximum input frequency f_{\max} of the drive controller:

$$Z = \frac{f_{\max}}{n_{\max}} \times 60$$

The maximum mechanical speed of the encoder must always be lower than the system speed.

Mounting method

The method of mounting the encoder on the motor must be considered. The appropriate housing variant must be selected accordingly.

The mounting is usually detailed in the encoder operation manual.

Robustness

The robustness is dictated by the behaviour and service life of the encoders depending on the vibration shock to which they are subject and the ambient temperature. Encoders are frequently systems based on optical scanning of code disks. In the event of severe vibration the evaluation and the encoder mechanism may be impaired or even destroyed. By contrast, resolvers are inductive measuring systems, and so are much less sensitive to vibration. Furthermore, their installation inside the motor protects them against external mechanical influences.

Temperature range and protection

In the case of servomotors without forced cooling the encoder is built-in to the motor housing. Consequently, no high demands are placed in terms of the encoder's protection. However, the interior of the motor housing is subject to operating temperatures of 100 °C and more. Resolvers meet the highest demands at this point; encoders are subject to a permissible temperature range of 115 °C to 120 °C.

Encoders for motors with forced cooling (e.g. IEC asynchronous motors) are either built-on or built-in to the motor housing. This means these encoders are often exposed to the contaminated cooling air flow of the motor, and so must be provided with high-level IP 64 protection or more. The permissible operating temperature rarely reaches more than 100 °C. For this temperature range various encoder types are available.

Encoder/drive controller compatibility

The following conditions with regard to the compatibility of the drive controller with the encoder interface must be taken into account when selecting:

- Voltage supply/current capacity
- Maximum signal input frequency of the drive controller
- Clock frequency of the serial absolute interface (SSI, Hiperface)
- Lowest representable speed of TTL/HTL incremental encoders and SSI absolute encoders without sin/cos signals
- Maximum permissible cable length

It is not possible to evaluate separate interference signals or functions to reset the position in the encoder using the c-line DRIVES.

EMC behaviour

In environments subject to strong electromagnetic radiation encoders with differential data transfer (e.g. via the RS-422 interface) should always be used. HTL encoder signals not permitting differential line connection to the c-line-DRIVES drive controllers may be subject to disturbance here, despite the higher signal-to-noise ratio.

Moreover, experience has shown that encoders with magneto-resistive components may be subject to disturbance if built onto the motor directly together with a holding brake, or if there is a magnetic coupling between the motor and the encoder.

Cabling

For most encoders prefabricated cables are offered in various lengths. Their use is urgently recommended, as they have been tested for correct functionality.

For details of how to connect the encoder to the drive controller refer to the relevant drive controller operation manuals, and as necessary to the encoder manual.

When connecting third-party encoders always use screened cables. The differential signals (e.g. A+ and A-) should be routed via twisted-pair cables. The cabling specifications of the encoder manufacturer must also be observed.

2.4.4 Interfaces

Hardware

RS422 interface

The RS-422 interface is standardized and operates symmetrically. The RS-422 interface is suitable for transfer rates up to 10 MB per second. At a Baud rate of 38400 Baud it is possible to transmit over 1 km cable length.

The RS-422 standard works with differential voltages. The advantage of this technique is that irradiated interference on the transmission path acts on both signal lines simultaneously and in the same way. As only the differential voltages of the two signal lines are evaluated by the receiver, the irradiated interference is irrelevant.

In this way much longer lines can be set up, and the restriction of interference also greatly increases the transfer rate.

The principle of the physical connection is shown in Figure 2.40.

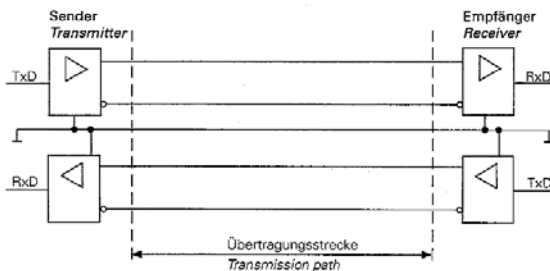


Figure 2.40 Hardware of the RS422 interface (source: Heidenhain)

Signal level

At the RS-422 interface the signals are outputted and read back in as differential voltages.

In this, a positive differential voltage corresponds to a logical "0" (OFF) and a negative differential voltage corresponds to a logical "1" (ON).

Differential voltages between $U_{dmin} = 2\text{ V}$ and $U_{dmax} = 5\text{ V}$ are outputted and the control identifies the differential voltages between $U_{dmin} = 0.2\text{ V}$ and $U_{dmax} = 6\text{ V}$ as logically defined levels.

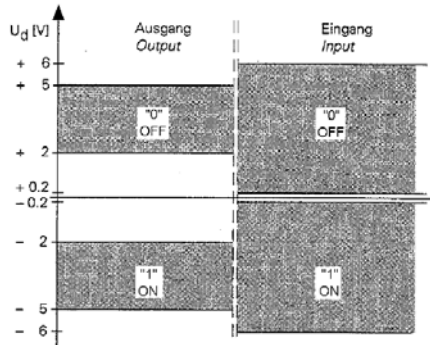


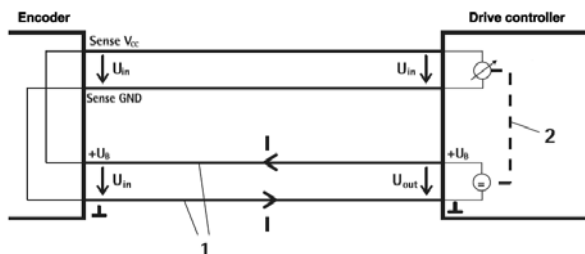
Figure 2.41 Signal levels of the RS422 interface (source: Heidenhain)

	Min.	Max.	Typ.
Input frequency of c-line DRIVES	0 Hz	500 kHz	
Input voltage <ul style="list-style-type: none"> • High level • Low level • Differential 	0.2 V	- 0.2 V ± 6 V	
Wave terminating resistance	-	-	120 W
Voltage supply for encoder (in part regulation via sensor cables possible)	4.75 V	5.25 V	V (150 mA)

Table 2.24 Electrical specification of the RS422 interface on the c-line DRIVES DRIVE CONTROLLER

Sensor cables

Various encoders require a voltage supply of $5 V_{DC} \pm 5\%$. To safeguard this tolerance additional sensor cables are required.



¹ Voltage drop due to long cables

² Automatic adjustment of output voltage

Figure 2.42 Connection of sensor cables (source: Hengstler)

The sensor cables permit measurement of the actual encoder voltage (excluding the corruption due to voltage drop resulting from the supply current and the cable resistance). Because of the voltage drop on the supply voltage lines the encoder input voltage U_{in} is lower than the voltage U_{out} outputted by the drive controller.

On the encoder the connected input voltage U_{in} is then outputted to the Sense V_{CC} and Sense GND cables and returned as information to the drive controller (high-resistance input).

On drive controllers with a Sense input the output voltage U_{out} can then be automatically adjusted.

2.5 Selecting gearing

The technically and commercially optimum speeds of the commonly used three-phase AC motors are too high for most applications. The essential reduction gearing is combined with the motor to form a three-phase AC geared motor (or servo geared motor) unit.

The particular advantage of gearing over an electronic speed reduction system is that the gearing not only reduces the speed but also the torque.

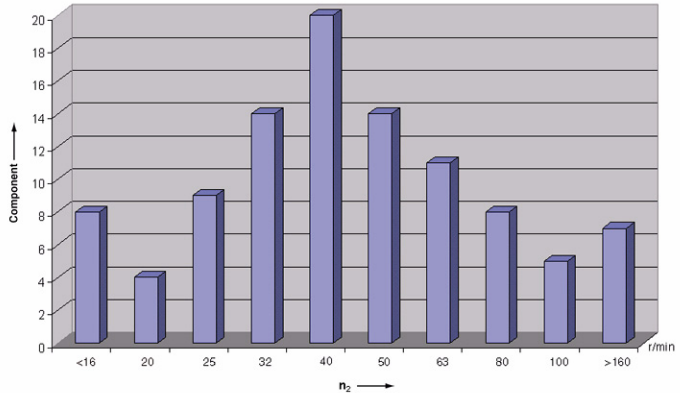


Figure 2.43 Typical output speeds (n_2) in industrial plant

The following sections set out the key gearing data in table form as well as providing definitions of terms. For precise data on designs, flux direction, torque, transmission, play etc. refer to the catalogues for the respective geared motors.

What points need to be considered in designing the gearing?

- Fitting location conditions (room conditions, temperature, position)
- Max. number of drives
- Max. output torque
- Service factor (the standard gears are designed for uniform load)
- Lateral forces, axial forces
- Circumferential backlash
- Torsional rigidity

2.5.1 Selecting standard gears

Characteristic values of standard gears

Properties	Spur gear	Flat spur gear	Worm gear	Bevel gear
Flux	Straight	Straight	Rectangular	Rectangular
Max. torque [Nm]	approx. 15.000	approx. 6.000	approx. 4.000	approx. 40.000
2. Shaft end	Not possible	Possible	Possible	Possible
Hollow output shaft	Not possible	Possible	Possible	Possible
Reduction range (without compound transmission)	approx. 3.5 to 230	approx. 6 to 270	approx. 6 to 290	approx. 6 to 165
Efficiency	0.93 to 0.98	0.93 to 0.98	0.3 to 0.85	0.9 to 0.96
Circumferential backlash in ¹⁾ angle minutes	approx. 30 to 40	approx. 30 to 40	approx. 30 to 40	approx. 25 to 40
Cost DM/Nm	Low	Low	Medium	High
1) Translation into degrees $15'/60 = 0.25^\circ$				

Table 2.25 Characteristic values of standard gears



- For all c-line drive controllers the transmission ratio can be set as the gear pairing (numerator/denominator), as a result of which the reduction ratio is processed mathematically precisely.
- The restoring efficiency (η_{rest}) is calculated by the formula:

$$\eta_{rest} = 2 - \frac{1}{\eta}$$

From this it is seen that self-locking occurs at an efficiency of $\leq 50\%$ (0.5).

Required information for selection of standard gears

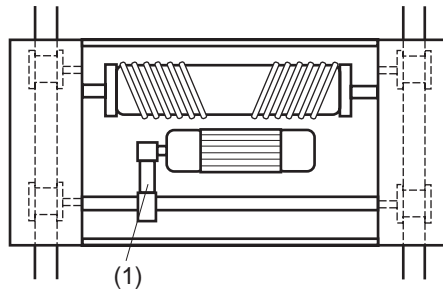
The following information is required for selection of standard gears:

- Drive torque
- Output speed
- Lateral forces/axial forces
- Required space/design
- Ambient conditions/temperature
- Load cycle
- Information on the mechanism (play, slack, mass moment of inertia etc.) to be driven.

The following provides an overview of the key factors in selecting standard gears.

Transmission gear

Insertion of a transmission gear stage between the geared motor and the output shaft results in different gear output speeds and torques.



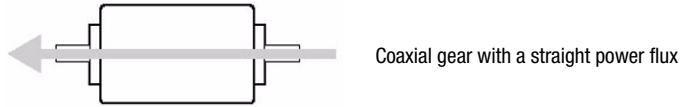
(1) Transmission gear with chain wheels

Figure 2.44 Transmission gear

Practical tip

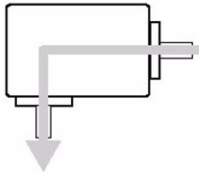
- In practice the transmission gear is usually implemented by way of toothed belts
 $i_{\max} \approx 4$, $i_{\text{typical}} = 2$ to 3
- $i_{\text{tot}} = i_v \cdot i_G$ Transmission gear reduction
 i_G Gear reduction

Power flux in gear



Coaxial gear with a straight power flux

Spur gear



Angular gear with a rectangular power flux

Worm gear
Bevel gear

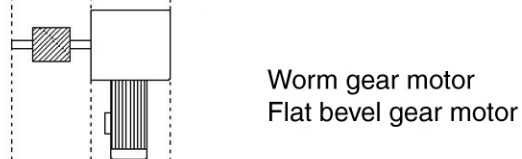
Space required by gearing



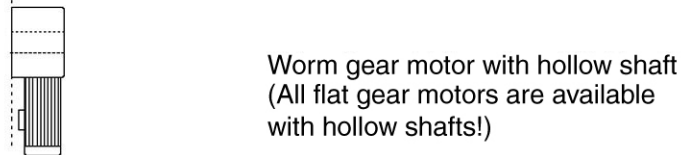
Spur gear motor



Flat spur gear motor



Worm gear motor
Flat bevel gear motor



Worm gear motor with hollow shaft
(All flat gear motors are available with hollow shafts!)

The technical data of the spur, flat spur and bevel gears are very similar. The choice of gearing often depends only on the fitting conditions!

Determining the drive torque in mains operation (fixed speed)

Standard gears are designed for uniform loading and low continuous duty factors. If these conditions are not met, it is necessary to multiply the calculated theoretical output torque and output power by a service factor typical to the application case.

$$M_{\max} = \frac{9550 \cdot P}{n} \cdot f_{\text{Btot}}^{1)} = [\text{Nm}]$$

1) Total service factor $f_{\text{Btot}} = f_{\text{B}}$ (gearing diagram) $\times f_{\text{B1}}$ (ambient temperature diagram) $\times f_{\text{B2}}$ (ED % diagram)



- The total service factor represents the ratio of the gear output to the motor output. Determination of the service factor is dependent on the manufacturer.
- In the case of worm gears, the influence of the ambient temperature and the continuous duty factor must be taken into account in addition to the service factor.

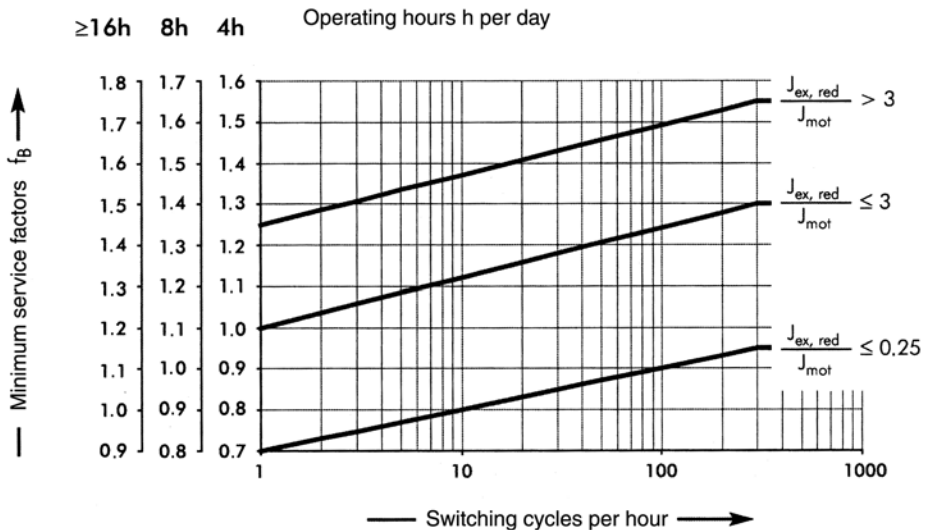


Figure 2.45 Typical diagram for service factors in mains operation (without frequency inverter)

Impact	Load type	Example	Worm gear [f _{Bges}]	Spur gear [f _{Bges}]	Daily operating time in h
I (A)	Uniform operation, small masses to accelerate, low switching frequency	Fan	0.80	0.80	3
		Centrifugal pump	1.00	1.00	10
		Inclined lift	1.20	1.20	24
II (B)	Non-uniform operation, medium-sized mass to accelerate, moderate shock impact, medium switching frequency	Kneader	0.90	0.90	3
		Sliding doors	1.10	1.10	10
		Gear pumps	1.30	1.30	24
III (C)	Non-uniform operation, low mass to accelerate, heavy shock impact, high switching frequency	Punching	1.10	1.20	3
		Mixer	1.30	1.40	10
		Clock drives	1.50	1.60	24

Table 2.26 Typical total service factor based on practice

Determination of output torque in controller operation (variable speed)

When the geared motor is operated on a drive controller the torque characteristic of the application must first be plotted (as per section 2.2 Motor selection).

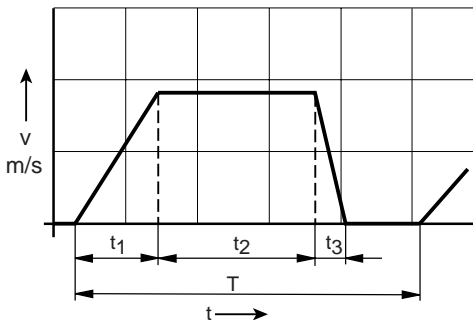


Figure 2.46 v/t diagram

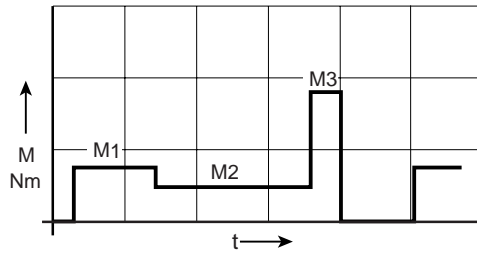


Figure 2.47 M/t diagram

The gearing should be selected according to the maximum torque occurring in the application. If the rated torque of the gear was exceeded in the application, the gear would be operating in the deformable range. This would result in shorter gear life.

$$M_{N \text{ Gear}} \geq M_{\max} \quad \text{referred to Figure 2.47} \geq M_3$$



In the case of worm gears, the influence of the ambient temperature and the continuous duty factor must additionally be taken into account.

Axial and radial forces

For the permissible axial and lateral forces refer to the gearing manufacturers' documentation.



Additional radial force

If gear wheels, chain wheels or belt pulleys are used to transmit torque, as well as from the torque the shaft is additionally subject to load from the radial force F_Q :

$$F_Q = (M / r) \times f_z$$

M = Torque

r = Radius

f_z = Supplement

Transmission elements	Comments	Supplement f_z
Gear wheels	≥ 17 cogs	1
	≤ 17 cogs	1.15
Chain wheels	> 20 cogs	1
	< 20 cogs	1.25
	< 13 cogs	1.4
Narrow V-belt pulley	Dependent on pre-tension	1.5 to 2
Flat belt with tension roller	Dependent on pre-tension	2 to 2.5
Flat belt without tension roller	Dependent on pre-tension	2.3 to 3
Drive via friction wheel	Common conditions in practice	3 to 4



For more information on efficiency and friction coefficients of mechanical elements refer to the book titled: "Das 1 x 1 der Antriebstechnik" [The ABC of Drive Engineering].

2.5.2 Selecting planetary gears

Characteristic values of planetary gears

Properties	Standard gear	Planetary gear	Bevel gear
Gear stages	1/2/3	1/2	1/2
Efficiency (without worm gear)	Very good	Very good	Very good
Circumferential backlash in angle minutes	approx. 25 to 40 ¹⁾	1 to 10 ¹⁾	6 - 15 ¹⁾
Impulse torques	Poor	Very good	Poor
Torsional rigidity	Medium	Very good	Medium
Dynamics	Medium	Very good	Medium
Power density	Poor	Very good	Poor
Transmission math. precise? (rating plate)	No	Yes	Yes
Cost DM/Nm	Low	Relatively high	Medium
1) Translation into degrees $15'/60 = 0.25^\circ$			

Table 2.27 Characteristic values of planetary gears

Required information for selection of planetary gears

The following information is required for selection of planetary gears:

- Drive torque
- Output speed
- Lateral forces/axial forces
- Circumferential backlash
- Design/power flux
- Ambient conditions/temperature
- Load cycle

In the following the new terms: impulse torques, circumferential backlash and torsional rigidity are explained.

Impulse torques

No service factor need be applied to planetary gears. Impact torque loads are permissible up to the maximum torque of the selected planetary gear, without reducing the rated or maximum torque.



Planetary gears are deployed for dynamic applications, so commonly these gears are not operated in the "deformable range". No service factor need be applied.

Depending on manufacturer, it may be that operation in the "deformable range" is permissible. When using a planetary gear of this kind, the service factor - also termed application factor - must be taken into account. If it is ignored, the service life will be significantly shortened.

Circumferential backlash

The circumferential backlash of a gear is the angular tolerance between the output and the drive, referred to the output shaft with the drive blocked and a drive torque of approx. 2 to 5 % of the rated torque of the gear.

- Figures are always absolute values and in angle minutes.
- Figure is obtained with drive shaft stopped.
- Figure relates to the output and is obtained by means of an alternating load of approx. 2 to 5 % M_{max} .

Torsional rigidity

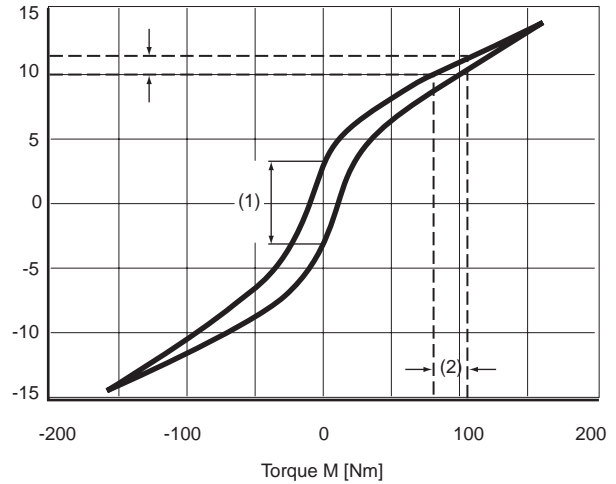
Torsional rigidity is the torsion of a gear relative to the loading.

- Figure always in Nm per angle minute.
- Figure is obtained with drive shaft stopped.
- Figure relates to the output and is obtained by means of an alternating load of approx. 0 to 100 % M_{max} .



Drive solutions with reduced-play bevel and spur gears can also be implemented.

Angle or rotation



- (1) Circumferential backlash 6'
- (2) Torsional rigidity 50 Nm per angle minute

Figure 2.48 Torsional rigidity

2.6 Selecting the motor brakes

In motor brakes a distinction is made in practice between spring-operated brakes (working brake) and permanent magnet brakes (holding brake). Standard three-phase AC motors are always fitted with spring-operated brakes. Synchronous and asynchronous servomotors are mostly fitted with permanent magnet brakes. In special cases spring-operated brakes may also be used.

	Spring-operated brake / working brake	Permanent magnet brake / holding brake
Typical area of application	IEC standard motors	Asynchronous and synchronous servomotors
Operating principle	Idle current brake (spring force)	Idle current brake (permanent magnets)
Value for money (Euro/Nm)	Good	Poor
Properties of the brake pad	Brake pad on metal	Metal on metal
Permissible lifetime switching cycles (number of emergency stops)	Very high	Very low
Braking current for venting	Medium	Low
Motor holding brake with double rated torque possible as braking torque e.g. for lifting drives	Yes	Yes (LSH)/ Depending on manufacturer
Moment of inertia of brakes	Depending on brake design concept	
Play		Play-free

Table 2.28 Characteristic values of motor brakes

Response times of spring-operated brakes

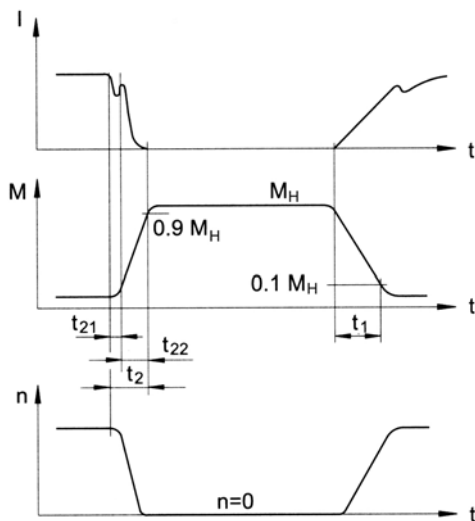
As standard brake motors are supplied with a connected rectifier for AC and DC side switching.

AC side switching:

Occurs upstream of rectifier on AC side. Here the magnetic field dissipates slowly, the brake engages gently on deceleration (switch-off time $t_2 \approx$).

DC side switching

Occurs between rectifier and coil, attaining an extremely short run-on. For all drives requiring precise braking, in particular also for lifting gear, DC side switching of the brake is essential (switch-off time $t_2 =$).



I	Coil current	t_1	Switch-on time
M	Braking torque	(T2)	Switch-off time
M_H	Holding torque of spring-operated brake	t_{21}	Delay time
n	Speed	t_{22}	Rise time
t	Time	$t_{2\sim}$	Time from power-off to reaching holding torque in AC side switching
		$t_{2=}$	Time from power-off to reaching holding torque in DC side switching

Spring-operated brakes. mechanical characteristic values																
Brake size		2	5	10	20	40	60	100	150	250	250	400	400	400	1000	1000
M_B	Nm	2	5	10	20	40	60	100	150	250	250	400	400	400	1000	1000
J_B	$\text{kgm}^2 \times 10^3$	0.015	0.015	0.045	0.172	0.45	0.86	1.22	2.85	6.65	13.3	19.5	39	39	181	181
t_1	ms	35	35	45	60	80	120	160	200	220	220	300	300	300	750	750
$t_{2\sim}$	ms	70	70	95	140	175	210	280	350	500	500	800	800	800	3500	3500
$t_{2=}$	ms	30	30	45	60	75	90	120	150	180	180	200	200	200	1000	1000
Attachable motor size		63	71	80	90	100	112	132	160	180	200	250	250	250	315	315
		71	80	90	100	112	132	160	180	200	225	280	280	280	-	-

Table 2.29 Mechanical characteristic values

Technical data of the permanently excited holding brakes of the LS motors

		Attachable motor sizes					
		LST-037	LST-050	LST-074	LST-097	LST-127	LST-158
J_B	[kg/cm^2]	0.015	0.08	0.2	0.6	2.0	6.2
M_H	[NM]	0.4	2.0	4.5	9.0	18	36
$t_{2=}$	[ms]	10	25	35	40	50	90
t_1	[ms]	6	6	7	7	10	22

Table 2.30 Mechanical characteristic values

$t_{2=}$ Time from power-off to reaching holding torque

t_1 Time from power-on to releasing the holding brake

3 Selecting drive controllers

3.1	c-line drive controllers	3-3
3.1.1	Acceptance tests/Ambient conditions	3-5
3.1.2	Modular heat sink concept	3-11
3.2	Measures for your safety	3-13
3.2.1	Intended use	3-14
3.2.2	System condition	3-16
3.2.3	Operation in IT network	3-20
3.2.4	Loading on the supply system	3-23
3.2.5	General points on the power connections	3-24
3.2.6	cUL approbation	3-27
3.2.7	Operation on fault current breaker	3-31
3.2.8	Leakage currents	3-32
3.2.9	Switching at the mains input	3-34
3.2.10	High-voltage test/Insulation test	3-34
3.2.11	Forming of the DC-link capacitors	3-35
3.2.12	Direction of rotation and terminal designation	3-37
3.2.13	Switching at the drive controller output	3-38
3.2.14	Short-circuit and ground fault proofing	3-40
3.2.15	Motor cable length, current and voltage losses	3-41
3.2.16	Voltage load on the motor winding	3-44
3.2.17	Motor protection possibilities	3-45
3.2.18	Bearing stress in drive controller operation	3-46
3.2.19	Calculation of effective drive controller capacity utilization	3-47
3.2.20	Measurement on the drive controller	3-49
3.2.21	DC network operation (DC coupling)	3-51

3.2.22	Calculation of the continuous braking power of internal braking resistors	3-52
3.3	c-line field busses	3-54
3.3.1	Overview on field busses	3-54
3.3.2	CAN-basics	3-55
3.3.3	CANopen profiles	3-68
3.3.4	PROFIBUS-DP Basics	3-83
3.3.5	Commissioning of drive controls on PROFIBUS/S7	3-91
3.4	c-line drive controller system CDA3000	3-97
3.4.1	Current capacity of drive controllers CDA3000 ...	3-97
3.4.2	Project planning for three-phase AC motors	3-100
3.4.3	Efficiency of the motor control methods of the CDA3000	3-103
3.4.4	Standard drive controller operation	3-108
3.4.5	70 Hz characteristic with 25 % field weakening	3-110
3.4.6	87 Hz characteristic / Expanded manipulating range	3-114
3.4.7	Multi-motor operation on one drive controller ..	3-117
3.4.8	Encoder selection for FOR mode with CDA3000	3-120
3.4.9	Programming examples for applications with CDA3000-PLC	3-126
3.4.10	Low motor losses based on CDA3000 with high-frequency PWM	3-143
3.5	c-line positioning drive CDE/CDB3000	3-145
3.5.1	Current capacity of positioning drives CDE/CDB3000	3-145
3.6	c-line servo and direct drive controllers CDD3000	3-149
3.6.1	Current capacity of servo and direct drive controllers	3-149

3.1 c-line drive controllers

The c-line drive system comprises three controller series. They are:

- Positioning drive series CDE/CDB3000 for
 - asynchronous standard motors up to 90 kW
 - synchronous servomotors up to 245 Nm
- Drive controller series CDA3000 for
 - asynchronous standard motors up to 132 kW
 - special motors such as high-frequency or reluctance motors
- Servo and direct drive controller series CDD3000 for
 - asynchronous servomotors up to 425 Nm
 - synchronous servomotors up to 245 Nm
 - hollow shaft motors up to 75 Nm
 - linear motors up to 2000 N

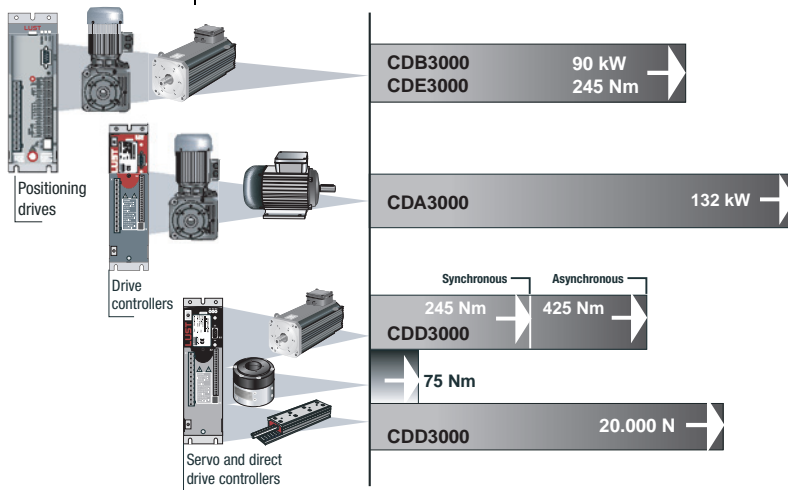


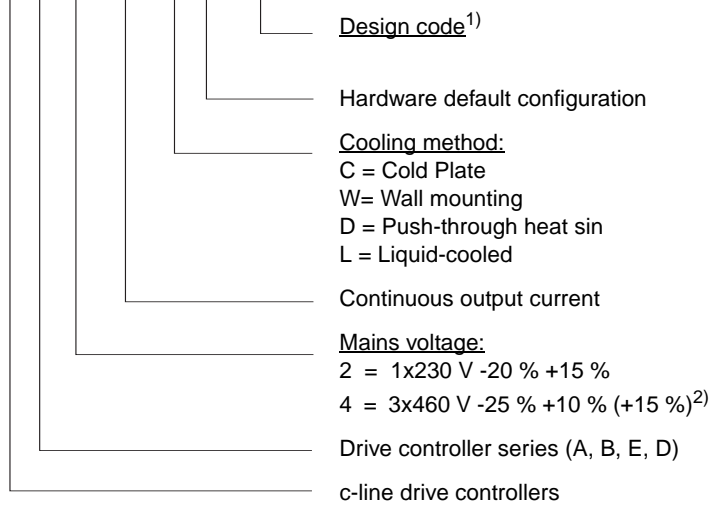
Figure 3.1 c-line DRIVES drive controllers



The following project planning notes do not apply to servocontrollers CDF3000 (24/48 V DC) and CDS4000.

Type codes of drive controllers

CDA **3x** **.xxx** **x** **x.x** **,xx**



- 1) The design code is separated by a comma. A maximum of 5 designs can be suffixed.
- 2) CDE/B3000 sizes 6 and 7.

3.1.1 Acceptance tests/Ambient conditions

All drive controller series are subject to the same acceptance testing conditions. **In the following the acceptance tests carried out are illustrated by the example of the CDE/CDB3000 drive controller series.** For detailed acceptance testing data refer to the latest user documentation for your drive controller.

CE mark

The drive controllers conform to the requirements of the EU Low Voltage Directive 73/23 EEC. The CDA3000 drive controllers are CE marked accordingly.

cUL approbation

The drive controllers are awarded cUL approbation. The cUL approbation is equivalent to UL and CSA approbation. For detailed acceptance testing data refer to the latest user documentation and/or section 3.2.6.

EMC acceptance tests

All CDE/CDB drive controllers have a sheet steel housing with an aluminium/zinc finish to enhance interference immunity to IEC61800-3, environments 1 and 2.

The CDE/CDB3000 drive controllers 0.37 kW to 7.5 kW and 22 kW to 37 kW are fitted with integral mains filters. Based on the measurement method stipulated by the standard, the drive controllers conform to the EMC product standard IEC 61800-3 for the "first environment" (category C2) and "second environment" (category C3).

- Public low voltage system (category C2) Residential: up to 10 metres motor cable length. For detailed data refer to the appendix to the relevant operation manual.
- Industrial low voltage system (category C3) Industrial: up to 25 metres motor cable length. For detailed data refer to the appendix to the relevant operation manual.

Assignment of drive controllers with external mains filter

For all drive controllers an external radio frequency interference (RFI) suppression filter (EMCxxx) is available. With this mains filter the drive controllers conform to the EMC product standard IEC 61800-3 for the "first environment" (category C2) and "second environment" (category C3).

- Public low voltage system (category C2) Residential: up to 100 metres motor cable length. For detailed data refer to the relevant order catalogue and/or section 4.3.
- Industrial low voltage system (category C3) Industrial: up to 150 metres motor cable length. For detailed data refer to the relevant order catalogue and/or section 4.3.



For more information on electromagnetic compatibility (EMC) refer to the latest user documentation and to sections 4.3 and 5.5.

Safety for electric drives

The type test of the c-line DRIVES was performed in conformance with the EN 50178 standard. We will be pleased to answer any questions you may have on the test setup.

Test features	Standard
Visual inspection	EN61800-5-1 Section 5.2.1
Air gaps / leakage distances	EN61800-5-1 Section 5.2.2.1
Test voltage for routine test	EN61800-5-1 Section 5.2.3.2
Leakage current measurement	EN61800-5-1 Section 5.2.3.5
Short-circuit resistance	EN61800-5-1 Section 5.2.3.6
Electric breakdown of components	EN61800-5-1 Section 5.2.3.8
Heating	EN61800-5-1 Section 5.2.3.9
Protective connection	EN61800-5-1 Section 5.2.3.10
Non-operational blowers	EN61800-5-1 Section 5.2.4.3
Insulation materials used acc. to	UL508C

Table 2.31 Typical test acc. to EN61800-5-1

Ambient conditions CDE/CDB3000

Attribute		Positioning Drive
Temperature-range ³⁾	in operation	-10 ... 45 °C (BG1 ... BG5) ²⁾ at 8 kHz -10 ... 45 °C (BG6 ... 7) at 4 kHz up to 55 °C with powerreduction ¹⁾
	in storage	-25 ... +55 °C
	in transport	-25 ... +70 °C
Relative humidity ³⁾		15 ... 85 %, condensation not permitted
pprotection category	device	IP20 (NEMA 1)
	Cooling method	Cold Plate IP20 Wall mounting IP20 Push-through heat sink IP54 (3 -37 kW)
Touch protection		VBG 4
Mounting high		up to 1000 m altitude, over 1000 m altitude with power output reduction of 1% per 100 m, max. 2000 m altitude
Voltage load on the motor winding		Typical voltage steepness 3-6 kV / μ s
1) not for controller CDB32.008,C and CDB34.003,C 2) -10 ... -40 °C for controller CDB32.008,C and CDB34.003,C 3) Enclosed you will find more information for the declaration.		

Tabelle 2.32 Ambient conditions CDE/CDB3000 and modules



Achtung: Do not install the drive controller in areas, which are exposed to vibration.
The certification of the drive controller will occur according to IEC68-2-6.

Temperature range and humidity acc. to EN61800-2

The drive controllers may be operated, transported and stored under environmental conditions specified in IEC60721-3-3. Exact values can be taken from the following tables.

Operation

Environmental influencing variable	Unit	Class 3K3
Low air temperature	°C	+ 5 ¹⁾
High air temperature	°C	+ 40 ¹⁾
Low relative humidity	%	5
High relative humidity	%	85
Low absolute humidity	g/m ³	1
High absolute humidity	g/m ³	25
Speed of temperature change ²⁾	°C/min	0,5
1) Other values can be taken from the corresponding operating instructions. 2) Averaged over a period of 5 min 3) Further information to these data can be found in the following.		

Table 2.33 Classification of climatic environmental conditions for operation of c-line drive controllers

Transport

Environmental influencing variable	Unit	Class 2K3
Low air temperature	°C	-25
High air temperature in non-ventilated containers ¹⁾	°C	+70
High air temperature in ventilated containers or in open air ²⁾	°C	+40
Relative humidity not in combination with rapid temperature changes	% °C	95 +40
Absolute humidity in combination with rapid temperature changes: Air/air with high water content ³⁾	g/m ³ °C	60 +70/+15
1) The surface temperature of a product can be influenced, on the one hand by the ambient air temperature specified here, and on the other hand by solar radiation through windows or other openings. 2) The surface temperature of a product is influenced by the ambient air temperature specified here and by the specified solar radiation. 3) Products are in most cases only designed for a rapid temperature drop (not for rapid temperature increase). The figures for the water content in the air are only applicable for temperatures down to the dew point. At lower temperatures a relative humidity of approx. 100 % is assumed.		

Table 2.34 Classification of climatic environmental conditions for transport of c-line drive controllers

Storage

Environmental influencing variable	Unit	Class 1K3	Class 1K4
a) Low air temperature	°C		-25
b) High air temperature	°C		+55
c) Low relative humidity ¹⁾	%	5	
d) High relative humidity ¹⁾	%	95	
e) Low absolute humidity ¹⁾	g/m ³	1	
f) High absolute humidity ¹⁾	g/m ³	29	
g) Speed of temperature change ²⁾	°C/min	0,5	
<p>1) The values for low or high relative humidity are limited by the values for low and high absolute humidity, so that e. g. the specified limits for environmental influencing variables a) and c) or b) and d) cannot occur at the same time.</p> <p>2) Averaged over a period of 5 minutes.</p>			

Table 2.35 *Classification of climatic environmental conditions for storage of c-line drive controllers*

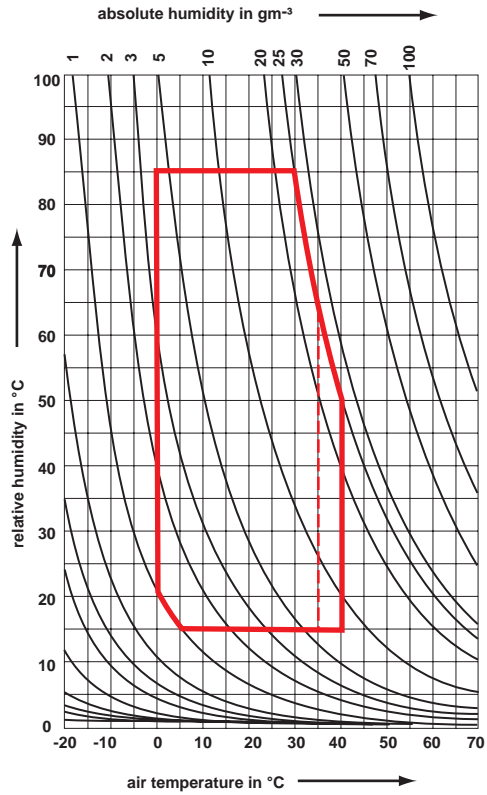


Fig. 3.2 Interrelationship between humidity and air temperature

3.1.2 Modular heat sink concept

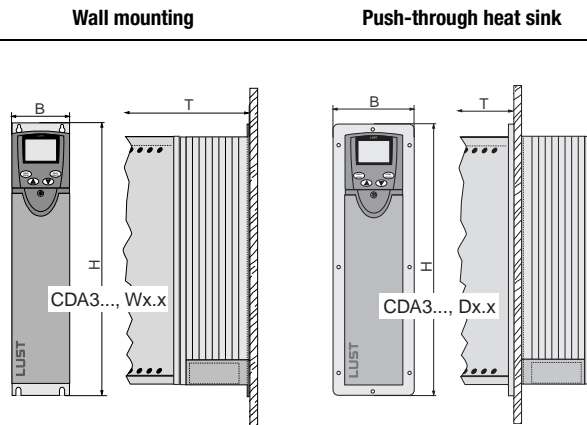
The modular heat sink concept offers solutions with:

- convection heat sink
- push-through heat sink
- cold-plate heat sink
- liquid heat sink

In the she standard supply program you will receive convection and push-through heat sink solutions. Liquid heat sinks and cold-plate heat sinks are offered only on request, as in those application cases a large number of marginal conditions need to be met.

Cooling methods

The base module of the positioning controllers offers two different mounting and cooling methods (example CDB3000, size 3)



Size	Power	Positioning drive	Wall mounting	Push-through heat sink	Cold plate	Water cooling
BG1	0.375 kW 0.75 kW	CDE/CDB32.003 CDE/CDB32.004	YES ¹⁾	NO	YES	NO
BG2	1.5 kW 0.75 kW 1.5 kW	CDE/CDB32.008 CDE/CDB34.003 CDE/CDB34.005	YES ¹⁾	NO	YES	NO
BG2	2.2 kW	CDE/CDB34.006	YES	NO	On request ³⁾	NO
BG3	3.0 kW 4.0 kW	CDE/CDB34.008 CDE/CDB34.010	YES	YES ²⁾	On request ³⁾	On request
BG4	5.5 kW 7.5 kW	CDE/CDB34.014 CDE/CDB34.017	YES	YES ²⁾	On request ³⁾	On request
BG5	11 kW 15 kW	CDE/CDB34.024 CDE/CDB34.032	YES	YES ²⁾	On request ³⁾	On request
BG6	22 kW 30 kW 37 kW	CDE/CDB34.044 CDE/CDB34.058 CDE/CDB34.070	YES	YES ²⁾	On request ³⁾	On request ³⁾
BG7a	45 kW 55 kW 75 kW	CDE/CDB34.088 CDE/CDB34.108 CDE/CDB34.140	YES	On request	NO	On request
BG7b	90 kW	CDE/CDB34.168	YES	On request	NO	On request
1) Equivalent to cold plate type with accessory heat sink HS3X.xxx						
2) Heat sink side protection is IP54						
3) These cooling methods are already supplied in production applications						

Table 3.1 Overview of modular heat sink concept



For more information on this subject refer to the latest user documentation and to sections 5.1 "Heat discharge from the switch cabinet" and 5.2 "Heat transfer by conduction".

3.2 Measures for your safety

The instructions set out below should be read through prior to initial commissioning in order to prevent injury and/or damage to property.

The safety instructions must be followed at all times.



Read the Operation Manual first!

- Follow the safety instructions!
- Refer to the user information!



Electric drives are dangerous:

- Electrical voltages 230 V/460 V: Dangerously high voltages may still be present 10 minutes after the power is cut. You should therefore always check that there is no voltage present.
- Rotating parts
- Hot surfaces



Protection against magnetic and/or electromagnetic fields during installation and operation:

- Persons fitted with heart pacemakers, metallic implants and hearing aids etc. must not be allowed access to the following areas:
 - Areas where drive systems are installed, repaired and operated.
 - Areas where motors are installed, repaired and operated. Motors with permanent magnets pose a particular hazard. If it is necessary to access such areas, suitability to do so must be determined beforehand by a doctor.



Your qualification:

- In order to prevent personal injury or damage to property, only personnel with electrical engineering qualifications may work on the device.
- The said qualified personnel must be familiar with the contents of the Operation Manual (cf. IEC364, DIN VDE0100).
- Knowledge of national accident prevention regulations (e.g. BGV A2 (VBG 4) in Germany).






During installation observe the following instructions:

- Always comply with the connection conditions and technical specifications.
- Comply with the standards for electrical installations, such as regarding wire cross-section, grounding lead and ground connections.
- Do not touch electronic components and contacts (electrostatic discharge may destroy components).

Pictograms used

The safety instructions detail the following hazard classes.
The hazard class defines the risk posed by failing to comply with the safety notice.

Warning symbols	General explanation	Hazard class to ANSI Z 535
	Important! Misoperation may result in damage to the drive or malfunctions.	Serious injury or damage to property may occur.
	Danger from electrical tension! Improper behaviour may endanger human life.	Death or serious injury will occur.
	Danger from rotating parts! Drive may start up automatically.	Death or serious injury will occur.

3.2.1 Intended use

Drive controllers are components that are intended for installation in electrical systems or machines. Compliance with the stipulated contamination level 2 laid down in IEC 61800-1, IEC 61800-2 and IEC 61800-4 must be ensured.

When installed in machines, the drive controller may not be commissioned (i.e. it may not be put to its intended use) until it has been established that the machine complies with the provisions of EC Directive 98/37/EC (Machinery Directive); EN 60204 is to be observed.

Commissioning (i.e. putting the device to its intended use) is only permitted in compliance with the EMC Directive (89/336/EEC).



The CDx3000 conforms to the Low Voltage Directive 73/23/ECC.

The harmonized standards of the EN 50178/DIN VDE 0160 series in conjunction with EN 60439-1/ VDE 0660 part 500 and EN 60146/ VDE 0558 are to be applied with regard to the drive controllers.

If the drive controller is used for special applications (e.g. in areas subject to explosion hazard), the required standards and regulations (e.g. EN 50014, "General provisions" and EN 50018 "Flameproof housing") must always be observed.

Repairs may only be carried out by authorized repair workshops. Unauthorized opening and incorrect intervention could lead to death, physical injury or material damage. The warranty provided by LUST would thereby be rendered void.



-
- Deployment of the drive controllers in non-stationary equipment is classed as non-standard ambient conditions, and is permissible only by special agreement.
 - In accordance with contamination level 2 as laid down in EN 61800-5-1, the drive controller must be installed in a housing/location offering at least protection class IP3x.
 - If the contamination level at the installation location is higher than category 2, the drive controller user must install it in a housing/location conforming to the stipulated contamination class (3 or 4).
-

Responsibility

Electronic devices are fundamentally not fail-safe. The company setting up and/or operating the machine or plant is itself responsible for ensuring that the drive is rendered safe if the device fails.

EN 60204-1/DIN VDE 0113 "Safety of machines", in the section on "Electrical equipment of machines", stipulates safety requirements for electrical controls. They are intended to protect personnel and machinery, and to maintain the function capability of the machine or plant concerned, and must be observed.

The function of an emergency off system does not necessarily have to cut the power supply to the drive. To protect against danger, it may be more beneficial to maintain individual drives in operation or to initiate specific safety sequences. Execution of the emergency off measure is assessed by means of a risk analysis of the machine or plant, including the electrical equipment to DIN EN 1050, and is determined with selection of the circuit category in accordance with DIN EN 954-1 "Safety of machines - Safety-related parts of controls".

3.2.2 System condition

DIN VDE 0100-300: 1996-01 differentiates between three network systems. It is made especially clear how the IT system differs from the TT and TN systems based on the means of ground connection.

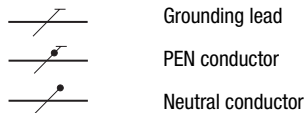
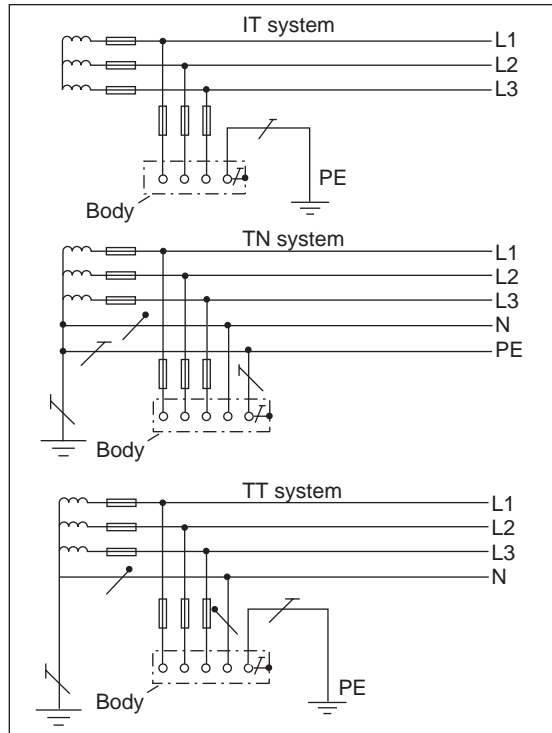


Figure 3.3 IT, TN and TT systems

First letter - Link from the supply system to ground:

- T Direct connection of a point to the ground
- I Either all active parts isolated from ground or one point connected to ground via an impedance.

Second letter - Link from the bodies of the electrical system to ground:

- T Body grounded directly, regardless of any grounding of a point of the supply system.
- N Body grounded directly with the grounded point of the supply system (in AC systems the grounded point is generally the centre point or, if there is no centre point, an outer conductor).

Voltage conditions in the IT system

In an IT system the voltages of the outer conductors are adjusted against ground according to the voltage distribution by the discharge impedances. These impedances comprise the capacitors of the conductors and those of the equipment against ground, and the parallel switched insulation resistors. If the said discharge impedances are equally large for every conductor, all outer conductors likewise conduct the same voltage against ground. High-resistance voltmeters connected between the outer conductor and ground display the same value. In three-phase AC systems this is the star voltage; in AC systems half the conductor voltage is displayed. Insulation monitors should therefore be connected symmetrically. If a ground fault occurs on a conductor, its voltage to ground collapses. However, because the voltage between the conductors is maintained the healthy conductors are raised to the conductor voltage against ground.

This increased voltage load may result in puncture at a point with low electrical insulation resistance, and this cause a double short circuit to frame.

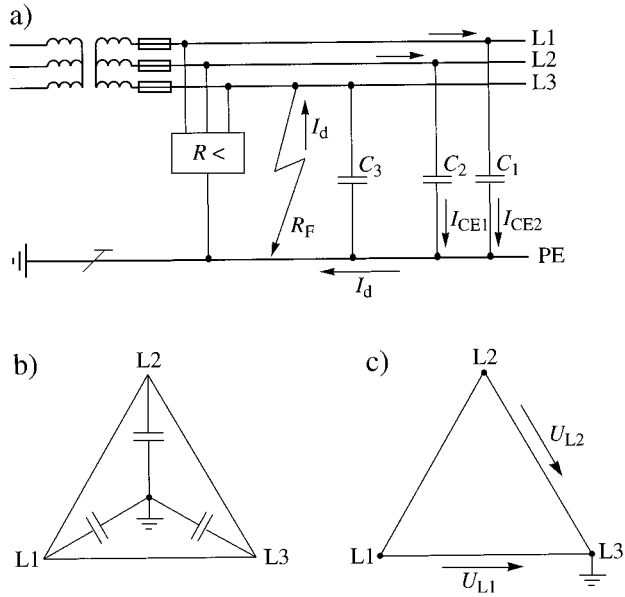


Figure 3.4 Voltage and current conditions in the IT system

- a) IT system with ground fault on conductor L3. The ground fault current I_d flows via the capacitors of the healthy conductors.
- b) Conductor voltage against ground with symmetrical conductor capacity. All conductors conduct the star voltage against ground.
- c) Conductor voltage against ground in the system with a ground fault on conductor L3. The healthy conductors conduct the conductor voltage against ground. It determines the amount of the ground fault current by way of the conductor capacitors.

System conditions for drive controller CDx3000

For operation of the CDx3000 drive controllers on the various mains power systems the following conditions must be met.

Power system	Operation with drive controller CDx3000	Comments
TN and TT	Permitted without restriction	<ul style="list-style-type: none"> • Pay attention to connection data • Best system form in terms of EMC
IT with insulated centre point	Operation of the drive controllers in this system type is not permitted.	See section 3.2.3 "Operation in IT network"

Table 3.2 System conditions



Operation of several CDx32,xxx (1 x 230 V) in the 3 AC/N/PE system: In order to achieve uniform system loading, the drive controllers should be split symmetrically across the three outer conductors. Pay attention to the loading of the common zero conductor, increase the cross-section as necessary.

3.2.3 Operation in IT network

Impairment of electrical safety and system availability when operating drive controllers with integral RFI filters in IT networks

In physically extensive systems, such as rolling mills, sugar plants, on-board networks on ships, chemical plant and crane installations, insulated supply systems (e.g. neutral conductor is not connected to ground on secondary side of medium voltage transformer) are frequently deployed. This is advantageous when equipment is operated outside of climate-controlled environments and due to the humidity occurring in those environments ground faults during operation must be expected in isolated instances.

The ground faults are detected electronically by centralized insulation monitors (section 5.8.3) and reported to the control room as a repair job requiring attention. The advantage of insulated systems is that the production process can be maintained without restriction despite a ground fault until a favourable point in the production logistics chain occurs when the equipment item concerned can be repaired or replaced.

The mode of operation of this system is largely dictated by the distributed parasitic capacitances (Y-capacitances) of the leads to the ground potential. If the sum of all parasitic Y-capacitances becomes too large, full ground fault detection is no longer possible.

However, RFI filters in variable-speed drives work primarily with Y-capacitors as return conductors for the high-frequency RFI currents to the inverter, and so may be incompatible with the system availability concept.

Moreover, in operation the maintenance personnel can no longer expect to encounter a merely low-capacitance grounded system - a fact which must be incorporated into the practical electrical safety measures.

For these cases IEC 61800-3 stipulates category C4. It provides for an EMC plan to be agreed with the user.

Operation of CDx3000 (0.75 to 7.5 kW) and CDE/B3000 (22 to 37 kW) in an IT network

The c-line drive controllers have been developed for operation in TN and TT systems.

Operation in an IT network is only permissible if no active system conductor is directly grounded and the bodies (inverter, motor etc.) are connected singly, in groups, or in totality to the PE conductor (ground).

The operating company must meet the following conditions:

1. The internal mains filter (see sections 3.1.1, 4.3 and 5.5) is still effective. IEC 61800-3 stipulates that a "system-specific" EMC plan must be implemented.

The operating company must verify that the leakage current generated by the internal mains filter is permissible. It must ensure that its centralized insulation monitoring remains fully functional as a result of the increase in parasitic Y-capacitances and the resultant additional leakage current.



-
- For the typical leakage currents and the measuring method to determine the leakage currents refer to section 3.2.8 "Leakage currents".
 - Note that the first time the drive controllers are powered up short-time high y-capacitor charging currents will occur.
-

2. The operating company must disconnect the inverter from the mains as quickly as possible when an insulation fault occurs (active conductor of IT system with ground fault), as in this case the Y-capacitors are operating above their rated voltage.

The inverter itself will not be damaged if operated in the IT network for less than 1000 hours in total with an insulation fault. This figure is laid down in EN 132400 as a minimum requirement at 1.7 times capacitor rated voltage for testing of y-capacitors.

Operation of CDA/D3000 (22 to 90 (132) kW) and CDE/B3000 (45 to 90 kW) in an IT network

The c-line drive controllers have been developed for operation in TN and TT systems. Operation in an IT network is only permissible if no active system conductor is directly grounded and the bodies (inverter, motor etc.) are connected singly, in groups, or in totality to the PE conductor (ground).

The operating company must meet the following conditions:

1. In order to safeguard the interference immunity (burst immunity) of the drive controllers, Y-capacitors are built into them.

The operating company must ensure that its centralized insulation monitoring remains fully functional as a result of the increase in parasitic Y-capacitances and the resultant additional leakage current. It must implement a "system-specific" EMC plan (category C4) in accordance with IEC 61800-3.

2. The operating company must disconnect the inverter from the mains as quickly as possible when an insulation fault occurs (active conductor of IT system with ground fault), as in this case the Y-capacitors are operating above their rated voltage.

The inverter itself will not be damaged if operated in the IT network for less than 1000 hours in total with an insulation fault. This figure is laid down in EN 132400 as a minimum requirement at 1.7 times capacitor rated voltage for testing of y-capacitors.



Note that the first time the drive controllers are powered up short-time high y-capacitor charging currents will occur.

3.2.4 Loading on the supply system

All drive systems draw a non-sinusoidal current from the system. This is because of the 1/3-phase input rectifier in the drive controller input. This non-sinusoidal current consumption results in voltage distortions (THD=Total Harmonic Distortion) in the system.

Depending on local conditions, line chokes may need to be inserted to reduce the voltage distortions. A line choke reduces the voltage distortion in the system by approx. 67 %.

System load

	Without line choke	With line choke	Change
	4 kW drive controller, mains impedance 0.6 mH	4 kW drive controller, mains impedance 6 mH	Without line choke to with line choke
Voltage distortion (THD)	99 %	33 %	-67 %
Mains current amplitude	18.9 A	9.7 A	-48 %
Mains current effective	8.5 A	6.23 A	-27 %
Commutation notches referred to the mains voltage	28 V	8 V	-70 %
Life of the DC-link capacitors	Nominal life	2-3 times nominal life	+200 to 300 %

Table 3.3 Change in system load resulting from insertion of a line choke with 4 % short-circuit voltage based on the example of a 4 kW c-line drive controller CDx34,010



For more information on the subject of system feedback of electric drives and on line chokes refer to the latest user documentation and to sections 4.1/5.3.

3.2.5 General points on the power connections

The minimum cross-section of the mains power cable is based on the local provisions (VDE 0298-4:1998-11), the ambient temperature and the specified rated current and rated voltage.

Current load capacity of multi-wire cables and assignment of protective devices to VDE 0298-4: 1998-11

Nominal cross-section in mm ²	Multi-wire cable (e.g. non-metallic sheathed cables or moveable cables)	
	Rated current of cable (Cu) in A ¹⁾	Protective device rated current in A ¹⁾
0.75	12	-
1.0	15	-
1.5	18	16
2.5	26	25
4	34	32
6	44	40
10	61	40
16	82	80
25	108	100
35	135	125
50	168	125
70	207	160
95	250	200
120	292	250
150	335	315
185	382	315
240	453	400
300	504	400

1) Figures apply to copper cables, at 30 °C ambient temperature.

Table 3.4 Current load capacity of multi-wire cables

Current load capacity of multi-wire cables dependent on ambient temperature to VDE 0298 part 4: 1998-11

Insulating material ^{*)}	NR/SR	PVC	EPR
Permissible operating temperature	60 °C	70 °C	80 °C
Ambient temperature °C	Conversion factors		
10	1.29	1.22	1.18
15	1.22	1.17	1.14
20	1.15	1.12	1.10
25	1.08	1.06	1.05
30	1.00	1.00	1.00
35	0.91	0.94	0.95
40	0.82	0.87	0.89
45	0.71	0.79	0.84
50	0.58	0.71	0.77
55	0.41	0.61	0.71
60	-	0.50	0.63
65	-	-	0.55
70	-	-	0.45

^{*)} At higher ambient temperatures based on manufacturer's specifications

Table 3.5 *Current load capacity of multi-wire cables dependent on ambient temperature*



For more information on current load capacity and protection of cables with PVC insulation refer to VDE 0100 Part 430.

Protection of the mains power cable

Normal gL/gG fuses can be used to protect the mains power cable¹⁾.

The fuses must be designed in conformance with local safety standards, the matching mains voltage and the corresponding rated input current of the drive controller.



If standard commercially available miniature circuit-breakers are used for protection purposes¹⁾, the tripping characteristic "C" must be configured.

1) The fuse does not protect the input rectifier bridge of the drive controller; it merely protects the cable.

**Minimum cross-section of the grounding lead to VDE 0100
Part 540**

Cross-section	PE mains connection
Mains power cable < 10 mm ²	Grounding lead (PE) cross section of at least 10 mm ² or lay a second electrical conductor parallel to the existing grounding lead, because the operational leakage current is > 3.5 mA.
Mains power cable >10 mm ²	PE conductor with cross-section of mains power cable - see VDE 0100 Part 540

Table 3.6 *Minimum cross-section of the grounding lead*

3.2.6 cUL approbation



The c-line DRIVES drive controllers are awarded cUL approbation. The cUL approbation is equivalent to UL Listing and CSA Certification.

For detailed acceptance testing data refer to the latest user documentation for your drive controller.

Definitions of terms:

UL Listing

The product conforms to the requirements in respect of all discernible hazards.

This approval does not apply to end-products which can be directly and universally used by the user, such as a PC, a drive controller, a monitor, an iron, etc.

UL Component Recognition

Product fitted as a component in end-products.

These components have been tested according to the manufacturer's specifications and conditions of use. No further requirements relating to the end-products (e.g. touch protection) are tested. Consequently, approval is granted only with restrictions subject to the proviso that the components in the end-product are used in accordance with their intended usage.

Component recognition is thus targeted only at manufacturers who install these components in their end-products. By contrast, any recognition of installed components does not affect the operators of the end-products. Examples of recognized components: Connectors, line chokes, motor chokes, fuses, circuit boards etc., as well as built-in units such as power supply units, drives or monitors, if built into a larger unit.

CSA Certification:

Product conforms to CSA requirements.

Products are classed "CSA-Certified" regardless of whether they are end-products or components. The CSA Report does, however, differentiate clearly, as well as stipulating the conditions of use and restrictions.

Multiple Listing

This applies where specific products are distributed by the manufacturers themselves under their own names and also through distributors. In such cases a joint application by both parties transfers the original approval to the distributor. No repeat acceptance testing is required.

cUL-listed drive controllers

Drive controller power stages	CDAxx.xxx.x....	CDBxx.xxx.x....	CDDxx.xxx.x....	CDExx.xxx.x....
32,003.C	✓	✓	✓	✓
32,004.C	✓	✓	✓	✓
32,006.C	✓	✓	✓	✓
32,006.W	✓	✓	✓	✓
32,008.C	✓	✓	✓	✓
32,008.W	✓	✓	✓	✓
34,003.C	✓	✓	✓	✓
34,003.W	✓	-	✓	-
34,005.C	✓	✓	✓	✓
34,005.W	✓	✓	✓	✓
34,006.W	✓	✓	✓	✓
34,008.W	✓	✓	✓	✓
34,010.W	✓	✓	✓	✓
34,014.W	✓	✓	✓	✓
34,017.W	✓	✓	✓	✓
34,024.W	✓	✓	✓	✓
34,032.W	✓	✓	✓	✓
34,044.W	1)	✓	2)	✓
34,045.W	✓	-	✓	-
34,058.W	1)	✓	2)	✓
34,060.W	✓	-	✓	-
34,070.W	1)	✓	2)	✓
34,072.W	✓	-	✓	-

Table 3.7 cUL-approved drive controllers

Drive controller power stages	CDAxx.xxx.X...	CDBxx.xxx.X...	CDDxx.xxx.X...	CDExx.xxx.X...
34.090.W	✓	-	✓	-
34.110.W	✓		✓	-
✓ Marked units are cUL-listed - Marked units are not cUL-listed 1) Only special units CDA54,xxx 2) Only special units CDD54,xxx				

Table 3.7 cUL-approved drive controllers



Attention: In generator mode (4 Q-operation) the cUL approved drive controllers CDx34.024,W and/or CDx34.032,W must be operated with external UR and approved braking resistors.



All CDA and CDD drive controllers are also approved in HF version (CDxxx.xxx,W,HF).

Measures to maintain UL approbation

1. Housing installation with IP54 protection and contamination level 2 is mandatory.
2. The devices may only be operated in systems of overvoltage category III.
3. Only UL approved fuses and circuit-breakers may be used.
 CDx32,xxx: Mains fuses min. 250 V H or K5
 CDE/B34,xxx to 34,032: Mains fuses 600 V H or K5
 CDA/D34,xxx: Mains fuses 600 V H or K5
 CDE/B34,044 to 34,070: 600 V - RK1
4. The devices are usable in systems with a maximum current capacity of 5000 A.

The connecting cables (mains power, motor and control cables) must be UL approved.

CDx32,xxx: Min. 300 V cables mains/motor), Cu 75 °C min.

CDx34,xxx: Min. 600 V cables mains/motor), Cu 75 °C min.

Device	Cable cross-section	Mains fuse
CDx32,004	AWG 16 [N/M]	10 A
CDx32,006	AWG 14 [N]/AWG 16 [M]	15 A
CDx32,008	AWG 14 [N]/AWG 16 [M]	20 A
CDx34,003	AWG 16 [N/M]	10 A
CDx34,005	AWG 16 [N/M]	10 A
CDx34,006	AWG 16 [N/M]	10 A
CDx34,008	AWG 14 [N/M]	15 A
CDx34,010	AWG 14 [N/M]	15 A
CDx34,014	AWG 12 [N/M]	20 A
CDx34,017	AWG 12 [N/M]	25 A
CDx34,024	AWG 10 [N/M]	30 A
CDx34,032	AWG 8 [N/M]	50 A
CDA/D34,045	AWG 6 [N/M]	50 A
CDA/D34,060	AWG 6 [N/M]	63 A
CDA/D34,072	AWG 4 [N/M]	80 A
CDA/D34,090	AWG 2 [N/M]	100 A
CDA/D34,110	AWG 1 [N/M]	125 A
CDA/D34,143	AWG 2/0 [N/M]	160 A

Table 3.8 Cable cross-sections - mains [N], motor [M], mains fuses

3.2.7 Operation on fault current breaker

In operation of the drive controller, because of the internal suppression capacitors, the high clock frequencies, the parasitic capacitors, the power stage, the motor cable and the RFI suppression filters the leakage current is > 3.5 mA. In individual cases it may be several hundred mA.

The drive controller must therefore always be thoroughly grounded (VDE 0100 part 540, EN 50178) in order to conform to the provisions regarding increased leakage currents applicable above 3.5 mA.

Fault current breakers must be used in accordance with local regulations. It should however be noted that, due to the three-phase input rectifier, the leakage current may contain a DC component.



Only all-current sensitive fault current breakers suitable for drive controller operation may be used.

FI compatibility: In case of fault the drive controller can generate DC fault currents without zero crossing. Consequently, the drive controllers may only be operated on all-current sensitive RCM type B fault circuit-breakers - see DIN VDE 0160 and DIN VDE 0664.



For more information on the subject of fault current monitoring refer to section 5.8.

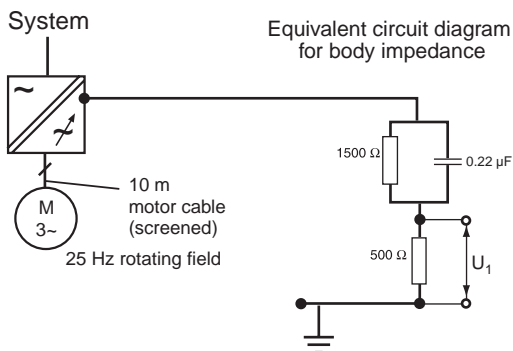
3.2.8 Leakage currents



Even in fault-free electrical devices and systems leakage currents from active currents may occur. Because of the design of the electrical systems, these currents discharge to ground. If, however, the PE conductor is broken, they also act as touch current.

A drive solution with c-line drive controllers usually has a leakage current of > 3.5 mA. The system should therefore be carefully grounded (VDE 0100) and conform to the requirements for leakage currents > 3.5 mA.

Typical leakage currents of the drive controllers



- 1) The leakage currents are determined once in the type test.

Figure 3.5 Typical measurement setup to determine the leakage currents of c-line DRIVES



Note that the leakage currents specified are exceeded on power-up of the device by the charging of the Y-capacitors.

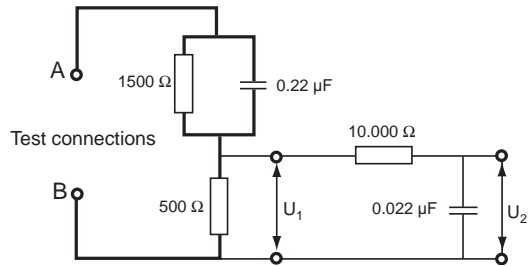


Figure 3.6 Future measurement setup to EN 60990

Controller	Controller ON (Standby) Motor OFF	Controller ON Motor ON
	[mA]	[mA]
CDx32,004	3.6	3
CDx32,006	3.1	8.1
CDx32,008	3.1	8.1

Table 3.9 Typical leakage current of 1-phase drive controllers with internal mains filter

Controller	Controller ON (Standby) Motor OFF	Controller ON Motor ON
	[mA]	[mA]
CDx34,003	1.4	4.4
CDx34,005	1.4	4.4
CDx34,008	1	3
CDx34,010	1	3
CDx34,014	1	6
CDx34,017	1	6
CDx34,024 ¹⁾	0.8	16.4
CDx34,032 ¹⁾	0.8	16.4
CDx34,044	11	12
CDx34,058	11	12
CDx34,070	11	12

1) Without internal mains filter

Table 3.10 Typical leakage current of 3-phase drive controllers with internal mains filter

3.2.9 Switching at the mains input



The mains connection of the drive controllers CDx3000 must be routed via an external mains isolator (e.g. power switch, contactor (AC3), etc.).

The mains isolator must conform to EN 60204-1 or local safety standards.

The mains isolator must not be used to control the drive controller (in jog mode) - extensive control functions are provided for that purpose.

The drive controller may be connected to the mains every 60 (120) s¹⁾. Too frequent connection will not result in destruction of the input circuit on the drive controller. The drive controller protects itself by means of high-resistance isolation from the mains. This is made possible by a special PTC precharge technique.

- 1) CDA3000 every 60 s
CDD3000 every 120 s
CDB3000 (3 to 32 A) every 60 s
CDE3000 (3 to 32 A) every 120 s
CDE/CDB3000 (44 to 72 A) every 30 s
-

3.2.10 High-voltage test/Insulation test



Every delivered drive controller is checked for insulation resistance between the main circuit and housing/frame by means of a high-voltage test (2.15 k VDC for 1 s). It is therefore not necessary to monitor the insulation resistance of the modules.

If the insulation resistance is nonetheless to be tested, the procedure set out below should be followed:

1. The high-voltage test must be performed prior to connection of the CDA3000 drive controller.
 2. The inputs and outputs U, V, W, +, -, RB, L1, L2 and L3 must be shorted.
 3. All control inputs and outputs must be connected to PE.
 4. The high-voltage test is performed by applying a maximum of 2150 VDC for 1 second. The voltage is applied between the shorting jumper at point 2. and the shorting jumper at point 3.
-

3.2.11 Forming of the DC-link capacitors

All U drive controllers have an input rectifier by which the 50/60 Hz AC or three-phase voltage is rectified. The rectified voltage is stored in the so-called **DC-link capacitors**. The motor-side power inverter in the output circuit of the drive controller reforms the DC link voltage into a new three-phase voltage system, with variable frequency (f) and voltage (u).

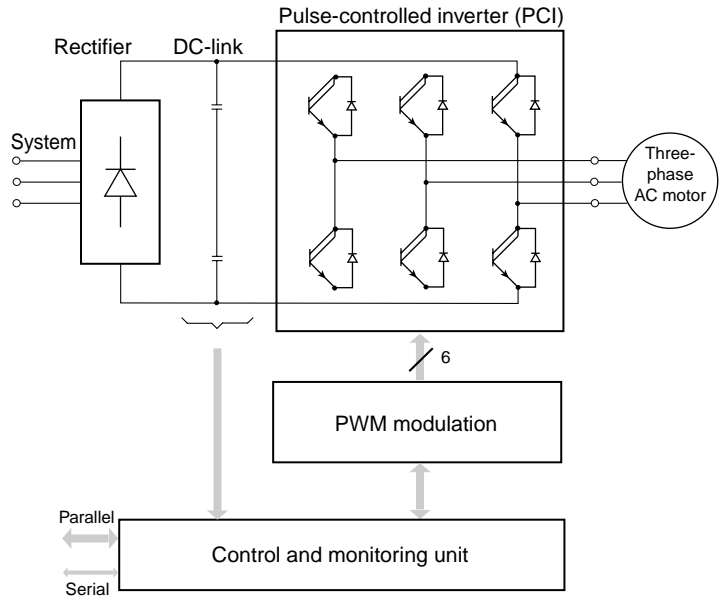


Figure 3.7 Block diagram of a voltage transformer

Forming of the DC-link capacitors (electrolytic capacitors)¹⁾

To form the DC-link capacitors the drive controllers must be connected to the mains power at 400/460 V (CDA34,xxx) approximately every 6 months for 1 hour. The time is dependent on the storage temperature: So drive controllers stored at < 40 °C only need be connected to the mains approximately every 12 months.

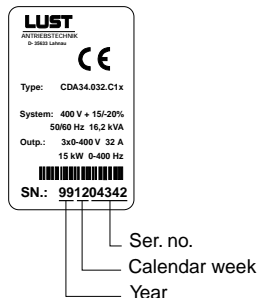


Figure 3.8 Drive controller rating plate with year and month identification



If the drive controllers have been left standing for more than 12 months (< 40 °C storage temperature) after shipping (see rating plate) the DC-link capacitors must be reformed. This can be avoided if the drive controllers are connected to the mains for one hour approximately every 6-12 months.



CDE/CDB:

Drive controllers CDE/CDB3000 as from 22 kW are fitted with MKP ²⁾ capacitors which do not need to be "formed".

If you need further assistance, such as to reform your capacitors ³⁾, our specialists on the LUST Helpline will be glad to help.

You can reach us:

Mon.-Thur.: 8 a.m. - 4.30 p.m. Tel. +49 6441/966-180

Fri.: 8 a.m. - 4 p.m. Tel. +49 6441/966-180

E-mail: helpline@lust-tec.de

Fax: +49 6441/966-177

1) Electrolytic capacitors

2) Metal-plastic-propylene capacitors

3) Forming treatment: The voltage is slowly raised to mains voltage according to special rules.

3.2.12 Direction of rotation and terminal designation

The direction of rotation is referred to the drive side.

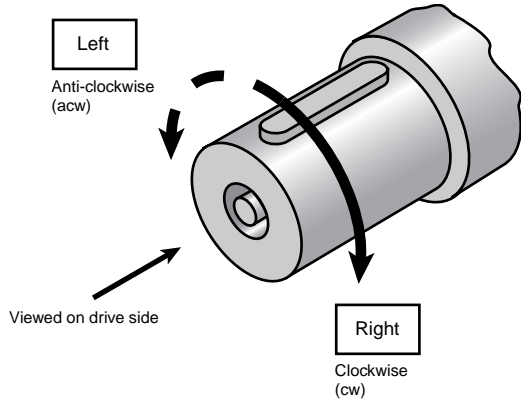


Figure 3.9 Direction of rotation

The terminals should be labelled such that the alphabetical order of the terminal designation (drive controller U, V, W - motor U1, V1, W1) corresponds to the phase sequence over time of the mains voltage (L1, L2, L3) in clockwise running.

Clockwise¹⁾	Terminals		
Drive controller CDx3000	U	V	W
Motor	U1	V1	W1
Anti-clockwise²⁾	Terminals		
Drive controller CDx3000	V	U	W
Motor	U1	V1	W1
1) Control signal "Clockwise"			
2) Control signal "Anti-clockwise"			

Table 3.11 Clockwise/anti-clockwise

3.2.13 Switching at the drive controller output



The motor connected to the drive controller ¹⁾ (CDA3000) may be isolated by means of a contactor or motor circuit-breaker. It is not possible to damage the CDA3000 drive controller by shutting down the motor.

When motor loads are shut off very high switching overvoltages occur, because the inductance of the motor does not permit stepped current changes. These switching overvoltage may also lead to fault shutdowns and/or error messages from the drive controller, depending on the drive configuration. In such cases a motor choke must be used.

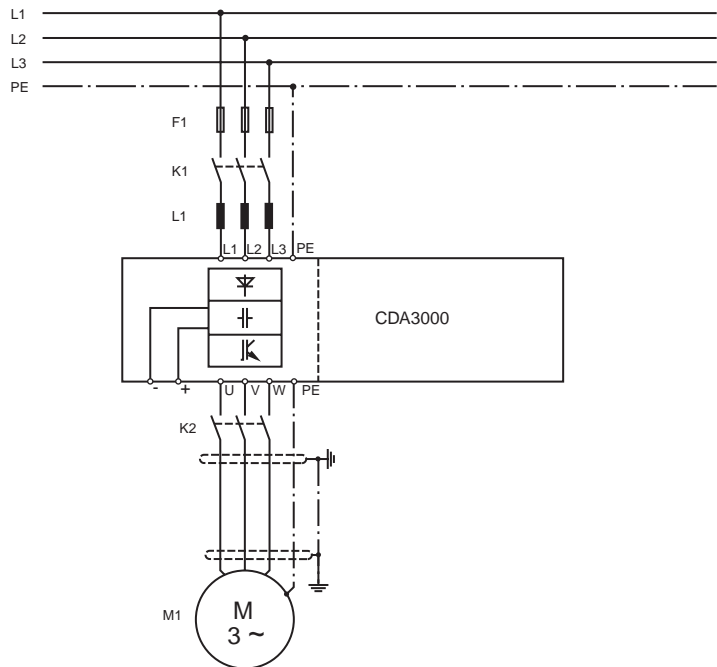


Figure 3.10 Circuitry example "Switching at the drive controller output"



Multi-motor operation: Several motors can be run in parallel on one CDA3000 drive controller (VFC mode). In this application case motors not only need to be shut down, but also activated. For details of the operating conditions under which such cases apply refer to section 3.4.7.

1) Drive controller without encoder feedback

Activation of energized motors or direct switching of the number of poles in variable-pole motors, and reversing the direction of the motor - such as by means of a reversing contactor - is not permitted during operation.

AC-3 contactor: If contactors of usage category AC-3 are used (conforming to IEC 947-4-1, EN 60947 or VDE 0660 part 102), the number of actuations must not exceed five per minute and 10 every 10 minutes. For higher actuating rates different switching elements should be selected accordingly.

At < 10 Hz the current is quasi DC, which may also cause the AC-3 contactor to overload.

Connection example for currentless switching

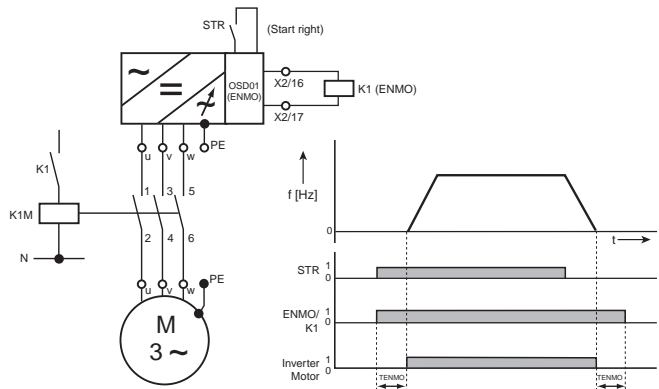


Figure 3.11 Connection example for ENMO. The screen connection is not shown.

3.2.14 Short-circuit and ground fault proofing

Function

Start control: Auxiliary contactor K1 is activated on start of control. The output frequency (output voltage) of the inverter is delayed by the time set in parameter 247-TENMO. This ensures that the motor contactor is closed before the output frequency (output voltage) of the inverter runs up.

Stop control: When "Start control" is cancelled the auxiliary contactor K1 drops out at a delay set in parameter 247-TENMO. This ensures that the motor contactor only opens when the power is cut to the power stage of the inverter.

The c-line DRIVES series drive controllers are fitted with one current sensor per motor phase. In the event of a short-circuit or ground fault in the motor cable, the power stage is disabled and an appropriate error message is delivered.

The CDx3000 drive controllers are short-circuit and ground fault proof in operation.

3.2.15 Motor cable length, current and voltage losses

Project planning notes on: Motor cable length, current and voltage losses


Subject	Project planning notes																
Rated current capacity of drive controllers	<p>The rated current capacity is specified in the relevant operation manual. The figure relates to the current available at the end of a 10 metre motor cable. For longer motor cables the current losses¹⁾ per metre must be incorporated into project planning. They are typically:</p> <table border="1" data-bbox="438 412 1146 623"> <thead> <tr> <th data-bbox="441 415 573 508">Clock frequency</th> <th data-bbox="573 415 766 508">Mains voltage 1 x 230 V [mA per m]</th> <th data-bbox="766 415 955 508">Mains voltage 1 x 400 V [mA per m]</th> <th data-bbox="955 415 1144 508">Mains voltage 1 x 460 V [mA per m]</th> </tr> </thead> <tbody> <tr> <td data-bbox="441 508 573 546">4</td> <td data-bbox="573 508 766 546">15</td> <td data-bbox="766 508 955 546">20</td> <td data-bbox="955 508 1144 546">20</td> </tr> <tr> <td data-bbox="441 546 573 585">8</td> <td data-bbox="573 546 766 585">20</td> <td data-bbox="766 546 955 585">40</td> <td data-bbox="955 546 1144 585">55</td> </tr> <tr> <td data-bbox="441 585 573 623">16</td> <td data-bbox="573 585 766 623">35</td> <td data-bbox="766 585 955 623">80</td> <td data-bbox="955 585 1144 623">100</td> </tr> </tbody> </table> <p>1) Current losses: These are switching losses in the power inverter caused by the capacitive leakage currents in the motor cable.</p>	Clock frequency	Mains voltage 1 x 230 V [mA per m]	Mains voltage 1 x 400 V [mA per m]	Mains voltage 1 x 460 V [mA per m]	4	15	20	20	8	20	40	55	16	35	80	100
Clock frequency	Mains voltage 1 x 230 V [mA per m]	Mains voltage 1 x 400 V [mA per m]	Mains voltage 1 x 460 V [mA per m]														
4	15	20	20														
8	20	40	55														
16	35	80	100														
Voltage losses on the motor cable	<div style="display: flex; align-items: flex-start;"> <div style="flex: 1;"> $\Delta U = \frac{1.6^{1)} \cdot l \cdot I}{56 \frac{\text{m}}{\Omega \cdot \text{mm}^2} \cdot A}$ <p>l = Length of motor cable in [m] I = Current in [A] A = Cable cross-section</p> <p>1) Typical factor for drive controller operation (1.73 x 0.9)</p> </div> <div style="flex: 0.5; text-align: center; margin: 0 10px;">  </div> <div style="flex: 1;"> <p>Multi-motor operation: The total length of the overall motor cable is produced by adding the individual lengths per motor.</p> </div> </div>																

Table 3.12 Project planning notes


Subject	Project planning notes												
Voltage losses on components	<table border="1" data-bbox="371 197 1077 520"> <thead> <tr> <th data-bbox="371 197 696 243">Component</th> <th data-bbox="696 197 1077 243">Voltage losses</th> </tr> </thead> <tbody> <tr> <td data-bbox="371 243 696 289">Line choke with 4 % U_K</td> <td data-bbox="696 243 1077 289">≈ 4 %</td> </tr> <tr> <td data-bbox="371 289 696 335">Mains filter²⁾</td> <td data-bbox="696 289 1077 335">< 0.1 %</td> </tr> <tr> <td data-bbox="371 335 696 381">Drive controller¹⁾</td> <td data-bbox="696 335 1077 381">≈ 6 %</td> </tr> <tr> <td data-bbox="371 381 696 428">Motor chokes²⁾</td> <td data-bbox="696 381 1077 428">≈ 3 - 5 % (at 50 Hz approx. 2 %)</td> </tr> <tr> <td data-bbox="371 428 696 520">Motor filter²⁾ (sine filter)</td> <td data-bbox="696 428 1077 520">≈ 4 - 8 % (at 50 Hz approx. 3 %) The voltage loss is partially compensated by an improved $\cos\phi$, see section 4.5.</td> </tr> </tbody> </table> <p data-bbox="337 531 1107 623"> 1) In the case of the CDE/CDB3000 drive controllers, from power stage 22 kW, voltage losses of up to 10 % are to be expected owing to the narrow DC link concept. 2) Observe maximum permissible motor cable length using mains filter, motor choke and motor filter (sine filter). </p>	Component	Voltage losses	Line choke with 4 % U_K	≈ 4 %	Mains filter ²⁾	< 0.1 %	Drive controller ¹⁾	≈ 6 %	Motor chokes ²⁾	≈ 3 - 5 % (at 50 Hz approx. 2 %)	Motor filter ²⁾ (sine filter)	≈ 4 - 8 % (at 50 Hz approx. 3 %) The voltage loss is partially compensated by an improved $\cos\phi$, see section 4.5.
Component	Voltage losses												
Line choke with 4 % U_K	≈ 4 %												
Mains filter ²⁾	< 0.1 %												
Drive controller ¹⁾	≈ 6 %												
Motor chokes ²⁾	≈ 3 - 5 % (at 50 Hz approx. 2 %)												
Motor filter ²⁾ (sine filter)	≈ 4 - 8 % (at 50 Hz approx. 3 %) The voltage loss is partially compensated by an improved $\cos\phi$, see section 4.5.												
EMC product standard EN 61800-3	<p data-bbox="337 639 1101 766">The maximum permissible motor cable length depends on the mains filters used (internal/external) and the environment (residential/industrial) in which the drive controller is deployed. With standard c-line DRIVES drive controllers solutions with up to 150 metres motor cable length are possible. For more details refer to the operation manual for your drive controller and to section 5.5.</p>												
Motor choke	<p data-bbox="337 785 1084 831">The maximum permissible motor cable length according to motor choke type is 30/50 metres. For more project planning notes refer to section 4.4.</p>												
Motor filter (sine filter)	<p data-bbox="337 870 1059 916">The maximum permissible motor cable length according to motor filter type is 250 metres. For more project planning notes refer to section 4.5.</p> <div data-bbox="346 931 413 997" style="display: inline-block; border: 1px solid black; padding: 2px; text-align: center;">  </div> <p data-bbox="472 924 933 982">Motor filters must not be used in drive systems with SFC¹⁾ or FOR²⁾ motor control mode.</p> <p data-bbox="337 1013 740 1059"> 1) SFC (Sensorless Flux Control) 2) FOR (Field Oriented Regulation with encoder feedback) </p>												

Table 3.12 Project planning notes

Subject	Project planning notes								
Encoder on motor	<p>The maximum permissible motor cable length for FOR-controlled drives is dictated to a major extent by the permissible length of the encoder cable. With standard c-line DRIVES drive controllers solutions with up to 100 metres encoder/motor cable lengths are possible. For more project planning notes refer to section 2.4.</p> <table border="1" data-bbox="438 312 1144 477"> <thead> <tr> <th data-bbox="438 312 766 358">FOR-controlled drive solution with ...</th> <th data-bbox="766 312 1144 358">Typical encoder/motor cable length</th> </tr> </thead> <tbody> <tr> <td data-bbox="438 358 766 397">CDA3000</td> <td data-bbox="766 358 1144 397">30 m</td> </tr> <tr> <td data-bbox="438 397 766 435">CDD3000</td> <td data-bbox="766 397 1144 435">50 m</td> </tr> <tr> <td data-bbox="438 435 766 477">CDE/CDB3000</td> <td data-bbox="766 435 1144 477">50/100 m ¹⁾</td> </tr> </tbody> </table> <p>1) For precise data refer to the relevant user documentation.</p>	FOR-controlled drive solution with ...	Typical encoder/motor cable length	CDA3000	30 m	CDD3000	50 m	CDE/CDB3000	50/100 m ¹⁾
FOR-controlled drive solution with ...	Typical encoder/motor cable length								
CDA3000	30 m								
CDD3000	50 m								
CDE/CDB3000	50/100 m ¹⁾								
Mounting height	<p>Master data of the drive controllers apply up to 1000 metres above mean sea level. With power reduction of 1 % per 100 metres the maximum mounting height achievable is 2000 metres above mean sea level.</p>								

Table 3.12 Project planning notes



Drive configuration: In designing a drive solution the above-mentioned conditions must be met. An additional requirement may be that the drive solution must continue working fault-free at 10 % undervoltage. Please carry out the appropriate over-dimensioning, as otherwise in some operating states the desired torque and/or speed will not be attained.

3.2.16 Voltage load on the motor winding

When a standard three-phase AC motor is operated on a drive controller the winding insulation is subjected to higher stress than in a sinusoidal system. The reason lies in the periodic switching operations by the drive controller which lead to high rates of rise of voltage (du/dt) and voltage peaks (U_{peak}) on the motor winding. This increased voltage load on the motor winding may shorten the service life of the motors - see the research report from the ZVEI in the "Bibliography and source references" section.

Market practice

Technology	du/dt Typical	Problems with IEC standard motor ¹⁾	Special motors ²⁾
Drive controller technology with standard transistors (on the market for over 15 years)	3-6 kV/ μ s	Not known	Isolated cases known
Drive controller technology with IGBTs	10-20 kV/ μ s	Isolated cases known	Isolated cases known
Drive controller technology with IGBTs and du/dt limitation to around 6 kV/ μ s	3-6 kV/ μ s	Not known	Isolated cases known
Drive controller technology with IGBTs and du/dt motor choke	< 1 kV/ μ s	Not known	Not known

1) With vacuum-saturated winding insulation (without air bubbles) and insulated winding heads
 2) Without vacuum-saturated winding insulation (with air bubbles) and without insulated winding heads

Table 3.13 Practical experience with du/dt voltage load

The rate of rise of voltage of the c-line DRIVES drive controllers is typically 2-6 kV/ μ s. For applications with special motors we provide a wide range of motor chokes and filters.



Our experience shows that no problems arise in connection with IEC standard motors with vacuum-saturated windings and insulated winding heads. However, the decisive factor in each individual case is the specifications of the motor manufacturer!

3.2.17 Motor protection possibilities

The following chart presents a summary of frequently occurring overload types and the possibilities for protection offered by various devices (motor circuit-breakers, thermistor protective relays, drive controller functions).

Motor protection possibilities

	A	B	C	D	C+D
Overload type	Motor circuit-breaker. e.g. PKZM) ¹⁾	Thermistor protective relay	Motor PTC monitoring of the drive controller	Software function: motor protection of the drive controller	Motor PTC monitoring and motor protection of the drive controller
Overload in continuous operation ²⁾	●	●	●	●	●
Heavy starting ³⁾	●	◐ ⁴⁾	◐ ⁴⁾	●	●
Blocking ²⁾	●	●	●	●	●
Blocking ³⁾	●	◐ ⁴⁾	◐ ⁴⁾	●	●
Ambient temperature >50 °C ²⁾	○	●	●	○	●
Impairment of cooling ²⁾	○	●	●	○	●
Drive controller operation <50 Hz	○	●	●	◐ ⁵⁾	●

○ No protection ◐ Limited protection ● Full protection

1) Operation in the motor cable between drive controller and motor permitted
 2) The drive controller and motor have the same power rating (1:1)
 3) The drive controller is at least four times larger than the motor (4:1)
 4) Effective when motor warm, too long response time when motor cold
 5) No full protection, because only the permissible current is applied as the basis

Table 3.14 Motor protection possibilities

In summary

From the point of view of "motor protection" the use of additional motor circuit-breakers or thermistor protective relays is not required. All required safety functions are provided by the drive controller as standard.

3.2.18 Bearing stress in drive controller operation



The subject of bearing stress and bearing currents is as old as the electric motor itself. Asymmetries in the design (magnetic field) of the motor have resulted in stresses on the bearing and the motor shaft, even with sinusoidal mains voltage. This phenomenon is increased somewhat by the drive controller-related bearing currents.

For more on this subject refer to the concluding report:

"Electrical bearing stress in drive controller-fed machines"

The report was drafted as part of the ZVEI/AiF research project carried out at the Technical University of Darmstadt in Germany.

Avoidance of bearing currents

To avoid bearing currents as far as possible, correct EMC grounding paths must be created so that high-frequency stray currents can find their way back to the drive controller without passing through the motor bearings.

Measures to avoid bearing currents

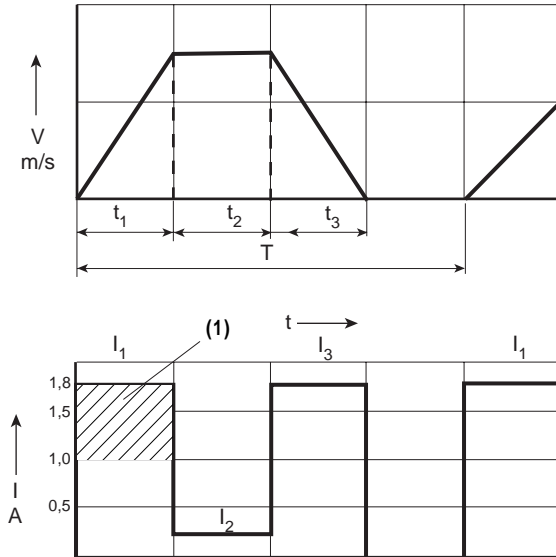
- Proper insulation of the motor bearings will interrupt the path of the bearing currents
 - Example: Use current-insulated roller bearings (INSOCOAT LAGER-SKF). These are motor bearings featuring an electrical insulation layer on their outer or inner races.

Measures to reduce bearing currents

- Use of high-grade bearings with good surface quality.
- Create correct EMC grounding paths.
 - Screened motor cables
 - Through-going screen
 - 360° screen contact
 - High-frequency ground connection
 - HF equipotential bonding band/grounding point
- Use of motor filter (sine filter) to smooth the high-frequency Common-Mode voltage and so reduce the bearing currents. In addition, the du/dt is reduced and the leakage currents are halved.

3.2.19 Calculation of effective drive controller capacity utilization

Calculation of effective drive controller capacity utilization



(1) Overload pulse

Figure 3.12 Effective drive controller capacity utilization

Calculation of effective drive controller current

$$I_{\text{eff}} = \sqrt{\frac{I_1^2 \cdot t_1 + I_2^2 \cdot t_2 + I_3^2 \cdot t_3}{T}}$$

Check that I_{eff} is $< I_N$ controller

The drive controller is determined with $I_{\text{eff}} \leq 0.95 \times I_N$ of the selected drive controller. Note that at least 5 % current reserve should be maintained for the ageing of a drive solution (machine/system).



3.

Check that the max. permissible overload pulse is not exceeded, otherwise the drive controller will shut down due to overload.

$$\left[I_{\text{Load}}^2 - I_{\text{N Controller}}^2 \right] \times t_{\text{Load pulse}}$$

For controllers CDx 0.37 kW to 15 kW:

$$[1.8^2 - 1^2] \times 30 \text{ s} \leq 67.2 \text{ A}^2\text{s}$$

For controllers CDA/CDD/CDB 22 kW to 90 kW:

$$[1.5^2 - 1^2] \times 60 \text{ s} \leq 75 \text{ A}^2\text{s}$$

For controllers CDE 22 kW to 90 kW:

$$[2^2 - 1^2] \times 30 \text{ s} \leq 90 \text{ A}^2\text{s}$$



Note that the rated current (I_N) depends on the selected power stage clock frequency.

3.2.20 Measurement on the drive controller

Measurement on the drive controller is **not** necessary, because the drive controller delivers all required actual values. Actual values such as:

- Motor frequency
- Motor speed/ torque
- Motor apparent current
- Motor active current
- Motor apparent power
- Motor active power
- Motor voltage
- DC-link voltage
- Motor temperature
- Heat sink temperature
- Device interior temperature
- etc.

are available. The actual values can be called up by way of the KP200/300 control unit or the DriveManager user software (with the digital scope function).



If measurements are nevertheless to be taken on the drive controller, the following conditions must be met.

Measurement on the drive controller

Because of the non-sinusoidal variables at the input and output of the drive controller, only measurements with special measuring equipment are permitted. Since such equipment is not usually available to practitioners on-site, conventional measuring equipment can be used as a fallback. A measuring circuit with device data is shown by the following Figure 3.13. It must be made clear, however, that the measuring equipment displays, especially at the drive controller output, deliver only guide values.

When using an oscilloscope to represent the pulsed voltage, measurements should be taken with differential inputs.

In all measurement operations you should remember that the DC-link capacitor on the voltage transformer may still be live long after the device has been shut off.

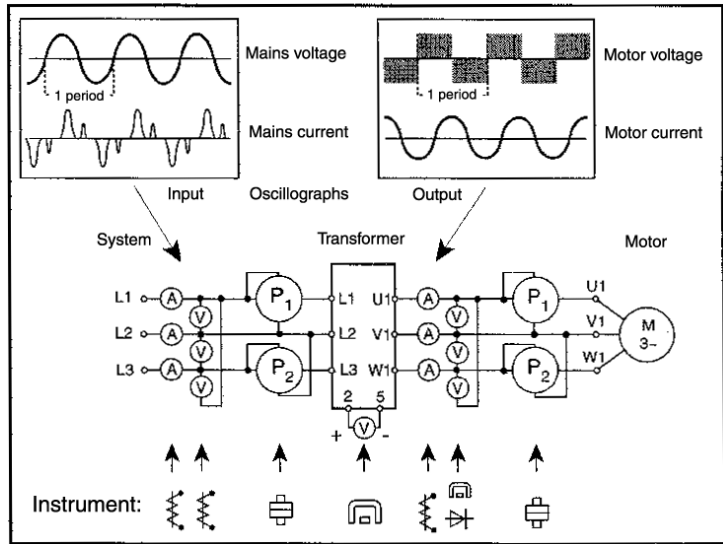


Figure 3.13 Measuring circuit for a voltage drive controller (suggested configuration) with oscilloscopes (block diagrams)

3.2.21 DC network operation (DC coupling)

DC network operation of the c-line drive controllers is permissible only with written approval from Lust.

To issue such an approval we require the following information:

1. What drive controllers and third-party products are to be operated in the DC network?
2. Describe the application case based on the questions set out in section 1.4 "Recording of movement task".
3. How long are the lines between the individual DC-link connections likely to be?

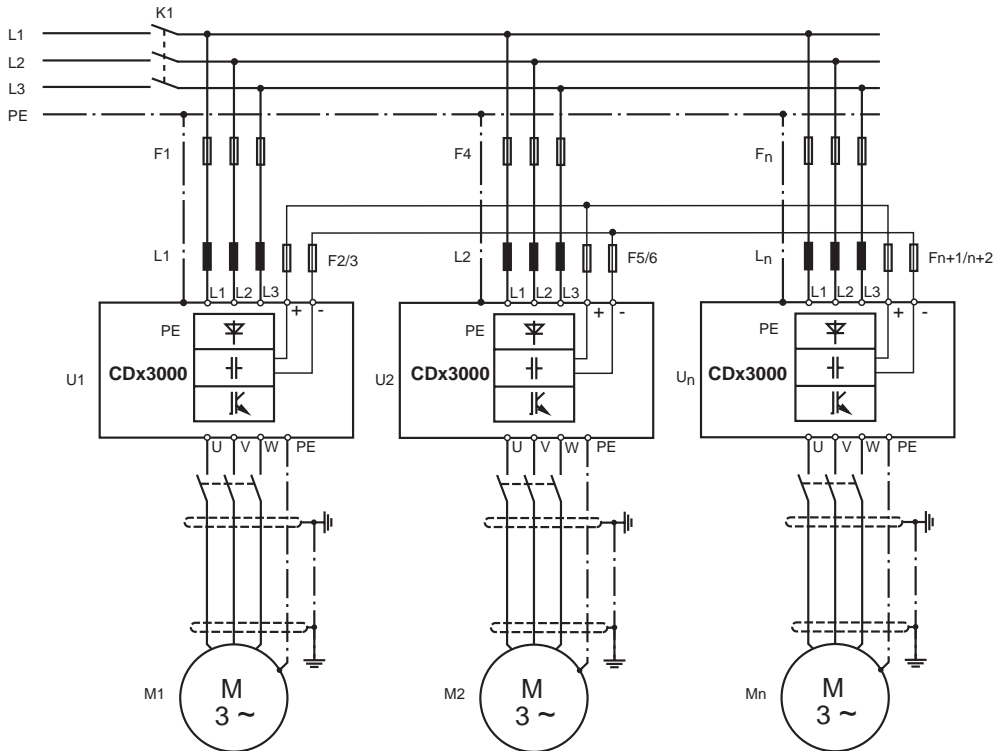


Figure 3.14 Circuitry example - DC network operation with c-line drive controllers

3.2.22 Calculation of the continuous braking power of internal braking resistors

For drive controller series with internal braking resistor (CDx3x.xxx,Wx.x,BR), there is just specified the peek braking power on the data sheet. The continuous braking power has to be calculated. It depends on the actual workload of the controller during application. The drive controller series with internal braking resistor is only efficient, if the actual workload of the controller is smaller than 80% or the braking resistor is provided for a unique emergency stop.

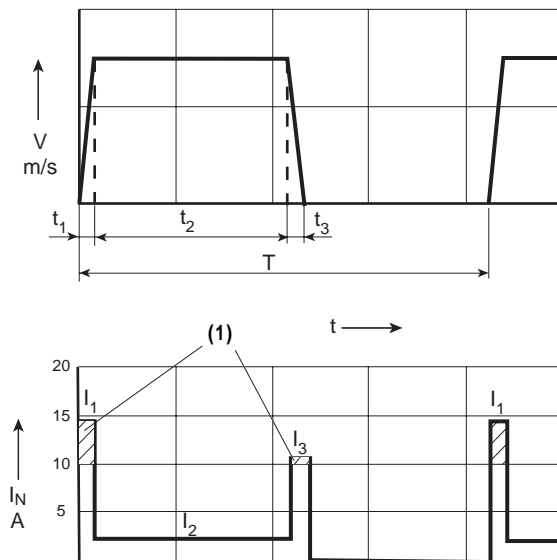
Example:

The continuous braking power of the internal braking resistor is sought for (CDA34.008,Wx.x,BR)

System related conditions:

Drive controller	CDA34.008Wx.x,BR
Switching frequency	8 kHz
Power dissipation of drive controller	162 W
Load cycle see	Fig. 3.15

Calculation of the effective drive controller load



(1) Overload pulse

Fig. 3.15 Effective driver controller load

Calculation of the effective drive controller load:

$$\begin{aligned}
 I_1 &= 14.04 \text{ A} \\
 I_2 &= 2.34 \text{ A} \\
 I_3 &= 10.92 \text{ A} \\
 t_1 &= 0.19 \text{ s} \\
 t_2 &= 2.0 \text{ s} \\
 t_3 &= 0.19 \text{ s} \\
 T &= 3.3 \text{ s}
 \end{aligned}$$

$$I_{\text{eff}} = \sqrt{\frac{I_1^2 \cdot t_1 + I_2^2 \cdot t_2 + I_3^2 \cdot t_3}{T}}$$

$$I_{\text{eff}} = \sqrt{\frac{14,04^2 \cdot 0,19 + 2,34^2 \cdot 2\text{ s} + 10,92^2 \cdot 0,19 \text{ s}}{3,3 \text{ s}}} \approx 4,64 \text{ A}$$



Please pay attention to the maximum permitted power and the current-time integral ($I^2 t$).

$$\text{Auslastung des Gerates (in \%)} = \frac{4,64 \text{ A}}{7,8 \text{ A}} \cdot 100\% \approx 60 \%$$

Calculation of the continuous Braking power (P_{DBR}):

$$\begin{aligned}
 P_{\text{DBR}} &= P_V \cdot \left(1 - \frac{I_{\text{eff}}}{I_N}\right) \\
 &= 162 \text{ W} \cdot \left(1 - \frac{4,64 \text{ A}}{7,8 \text{ A}}\right) \\
 &= 65,63 \text{ W}
 \end{aligned}$$



Attention: This only applies for a utilization of the device from 50% of its rated power and higher. At a utilization of the output stage of less than 50%, the dissipated braking energy must not exceed 50% of the power dissipation of the device.

3.3 c-line field buses

3.3.1 Overview on field buses

	PROFIBUS	CANopen	DeviceNet	Interbus	SERCOS II	SERCOS III	LON
Manufacturer	Siemens, Pepperl+Fuchs, Klöckner-Möller, Schneider Automation a.o.	Chips: Intel, Philips, Semiconductors, Motorola, Siemens Systems: I+ME, Softing, ESD, Bosch, Daimler Benz a.o. Application Layer: CiA (CAN in Automation)	/ Hardware like CAN / Application Layer: ODVA (Open DeviceNet Vendor Association)	Phoenix Contact	Interessengemeinschaft Sercos Interface e.V.	Interessengemeinschaft Sercos Interface e.V.	LNO (LON Nutzer Organisation e.V.)
Topology	Line	Line, (star)	Line, (star)	Ring	Ring	Ring, line	Line, star, ring
Length of bus line	Cu: 100 m at 12 Mbit/s 200 m at 1,5 Mbit/s 400 m at 500 kbit/s 1000 m at 187,5 kbit/s 1200 m at < 93,5 kbit/s LWL: several km	25 m at 1 Mbit/s, 500 m at 125 kbit/s, 5 km at 10 kbit/s	100 m at 500 kbit/s, 250 m at 250 kbit/s, 500 m at 125 kbit/s	400m max. 13 km on Cu basis	Optical fibre cable per transmission link: 50 m plastic OWG, 250 m glass fibre	Fast Ethernet	130 m - 2700 m (Twisted Pair)
Transmission rate	9,6 kBit/s; 19.2 kBit/s; 93.75 kBit/s; 187.5 kBit/s; 500 kBit/s (FMS); 1.5 MBit/s (DP); 12 MBit/s (DP)	10 kbit/s, 20 kbit/s, 50 kbit/s, 125 kbit/s, 250 kbit/s, 500 kbit/s, 800 kbit/s, 1 Mbit/s	125 kbit/s, 250 kbit/s, 500 kbit/s,	500 kbit/s constant	2, 4, 8, 16 Mbit/s	100 Mbit/s	300 Bit/s - 1.25 Mbit/s
Cycle time	Depending on transmission rate and data quantity	Depending on transmission rate and data quantity	Depending on transmission rate and data quantity	1 ms 1 E/A to 7.8 ms at 1096 I/O	62.5 µs, 125 µs, 250 µs up to 65 ms. Depending on transmission rate and data quantity	31,25 µs up to 3 ms (depending on subscribers and data quantity)	Depending on transmission rate and data quantity

Table 3.15 Overview field buses

	PROFIBUS	CANopen	DeviceNet	Interbus	SERCOS II	SERCOS III	LON
Transmission medium	Two-core Cu RS 485 Two-core CU with auxiliary power (IEC1 158-2) optical fibre cable	Two-core Cu, optical	Two-core Cu, optical	Twisted Pair, glass fibre, radio, infrared	Optical fibre cable	Fast Ethernet (copper cable)	Twisted Pair, glass fibre, radio, infrared
Number of subscribers	32 per segment, maximum 126 (with repeater)	Depending on Physical Layer, logically limited to 127	Logically limited to 64 subscribers	512 subscribers, maximum 4096 I/O	254 per OWG ring	max. 254	max. 127 per Subnet dep. on transceiver (max. 32.385 nodes for 255 Subnets)
Telegram length	User data + 9 Byte	130 Bit	130 Bit	256 words	-	-	max. 255 Bytes
User data length	244 Byte	8 Byte	8 Byte		2, 4, 6, 8, 16 Byte	40 to 1494 Byte	typically 10- 16 Bytes

Table 3.15 Overview field buses

3.3.2 CAN-basics

Summary of CAN features

- Variable transmission rate up to 1MBit/s
- Cable length of up to 1000 m with reduced transmission rate
- Self-synchronizing bit coding
- short messages (0-8 Byte)
 - short transmission time
 - guaranteed latency time
- Multi-Master architecture
 - each bus subscriber has access to the transmission medium
 - automatic resolution in case of synchronous access
 - Broadcast communication
- High noise immunity
- Mechanisms for network management and configuration

CANopen structure

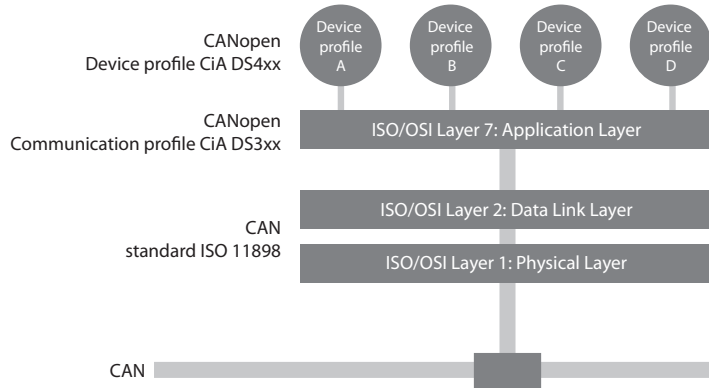


Fig. 3.16 CANopen structure

Important CANopen communication and device profiles

- **CiA DS 301 (V4.02)** - Definition of CANopen application layer, communication profile and network management for CANopen Slaves. Certified as EN-Standard EN 50325-4
- **CiA DR 303-1 (V1.3)** - Defines the type of wiring and connection
- **CiA DS 306 (V1.3)** - Defines the format and content of the electronic data sheet "EDS" for CANopen devices
- **CiA DSP 402 (V2.0)** - Device profile for drives and motion controls (constitution machine, movement modes)

Object directory

- Interface between drive controller and CAN-Bus
- Basis for device description – access to all parameters
 - Mandatory and optional (additional) objects
- The object directory is subdivided into various groups
- Each object is addressed by a 16 bit index, in case of fields additionally with an 8 bit sub-index

Index	Description
0000h	reserved
0001h - 025Fh	Data Types
0260h - 0FFFh	reserved
1000h - 1FFFh	Communication object area
2000h - 5FFFh	Manufacturer specific area
6000h - 9FFFh	Device profile specific area
A000h - BFFFh	Interface profile specific area
C000h - FFFFh	reserved

Table 3.16 Object directory

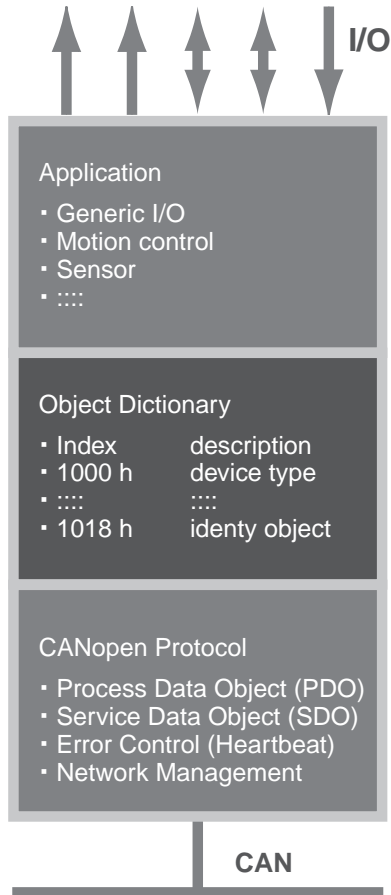
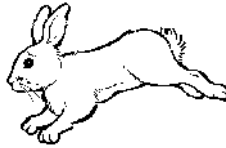


Fig. 3.17 Object directory as interface between application and CAN-Bus

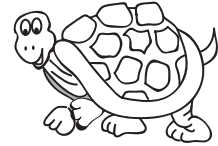
Data objects

PDO (Process Data Object)



- Real-time data
 - Drive controller
- High-priority unambiguous identifiers
- max. 8 Bytes (1 telegram)
- Configurable content (mapping)

SDO (Service Data Object)



- System parameters
 - Parameter handling
 - Parameter set download
 - Access to all parameters
- Low-priority identifiers
- Data distributed over several telegrams
- Data addressed by index

Communication model

The PDO (Process Data Object) enables any data exchange between modules.

The SDO (Service Data Object) enables point-to-point data exchange with a configuration master.

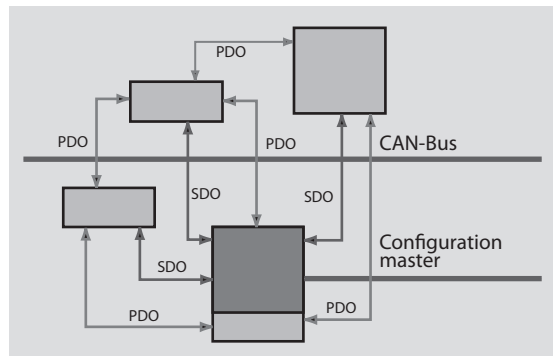


Fig. 3.18 Communication model

Process Data Object (PDO)

- Various types of transmission
 - Synchronous - utilization of the SYNC-Object (cyclic and acyclic in case of event in drive)
 - Asynchronous (event controlled/time controlled)
- Additionally various trigger modes
 - Event triggered (e.g. SYNC or state change)
 - Time controlled (in drive)
 - On request (not supported by c-line-Drives)

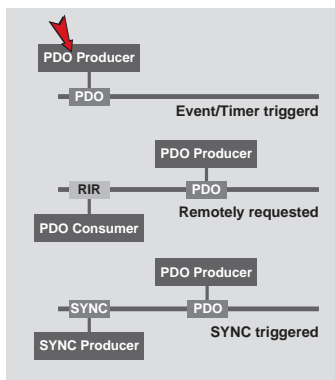


Fig. 3.19 PDO trigger modes

- Configurable PDO-content (mapping)
 - Setting via configuration parameters in object directory
 - Max. 8 byte

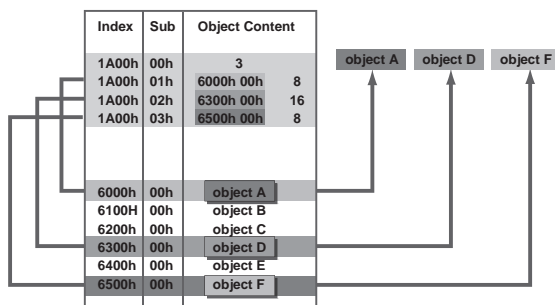


Fig. 3.20 PDO Mapping

Fig. 3.20 shows the mapping of objects 6000h, 6300h and 6500h in TxPD01. For this purpose the contents of TxPD01 are entered into object 1A00h.

Service Data Object (SDO)

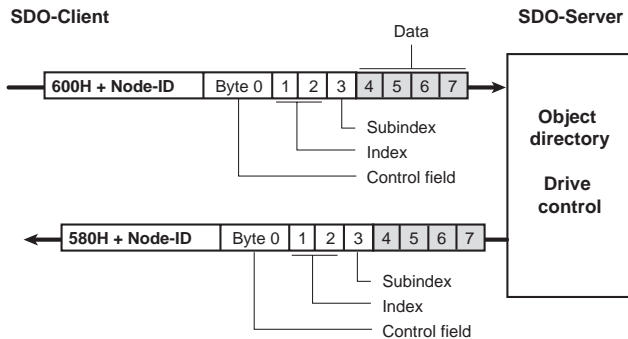


Fig. 3.21 SDO

- Example: Writing parameter 150-Save = 1

write	SDO-ID: 601 h	22	96	20	00	1	0	0	0
answer	SDO-ID: 581 h	60	96	20	0	0	0	0	0

Network management (NMT)

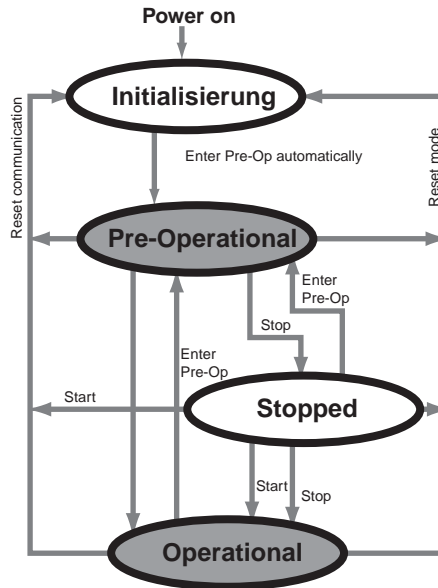


Fig. 3.22 Network management

- State machine of bus system with
 - Boot-Up sequence
 - Control by network master (not implemented in c-line-Drives)
- Various states
 - Pre-Operational
SDO active,
Sync + Emergency possible
 - Operational
SDO + PDOs active
Sync + Emergency possible
 - Stopped
no SDO, PDO and Sync,
only NMT messages (e.g. Heart-Beat)
 - Status transitions
CAN-telegram with COB-ID 0
and 2 data bytes:
1st byte: 1 (Start); 80H (Enter Pre-Op)
2nd byte: Node-ID (0 = all nodes)

SYNC Object

- Function for synchronized data transfer/output in field devices
- SYNC-object is sent by the bus master to all field devices as broadcast telegram
- Jitter possible with higher priority identifiers

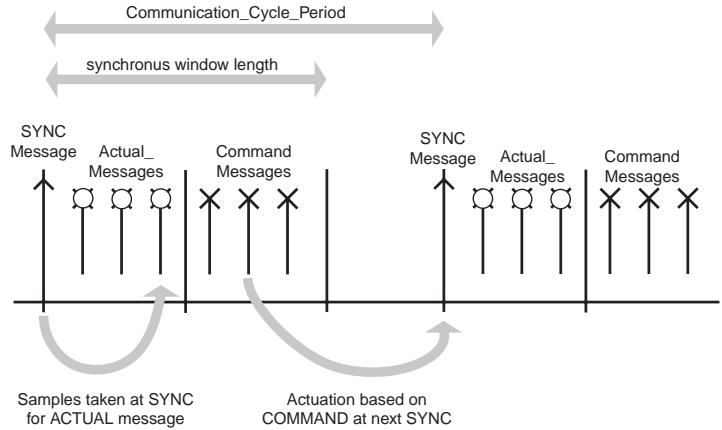
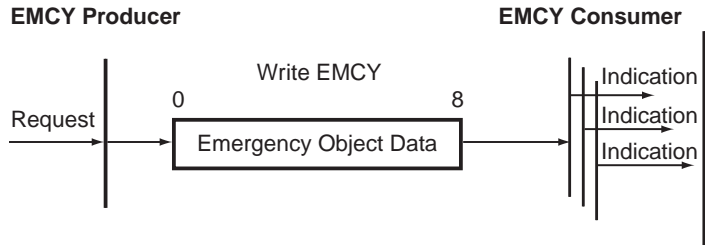


Fig. 3.23 Synchronization

Emergency Object

- Reporting of device error by originator
- Error codes are defined in DS 301 / DSP 402
- Manufacturer specific error codes possible
- Error message is only transmitted once, if error does not reoccur
- Several bus subscribers can receive the message and respond accordingly
- Function is "optional"



Heartbeat Protocol

- Heartbeat is an error control service
 - NMT function
 - Transmission of device status and presence of device
 - Monitoring of whether the node works correctly
- The heartbeat message is cyclically sent by the producer
 - No Remote-Frames (requests) required, as with Node-Guarding
 - The message can be monitored by several consumers
 - Dispatching the message generates a heartbeat event
- No parallel use with Node-Guarding

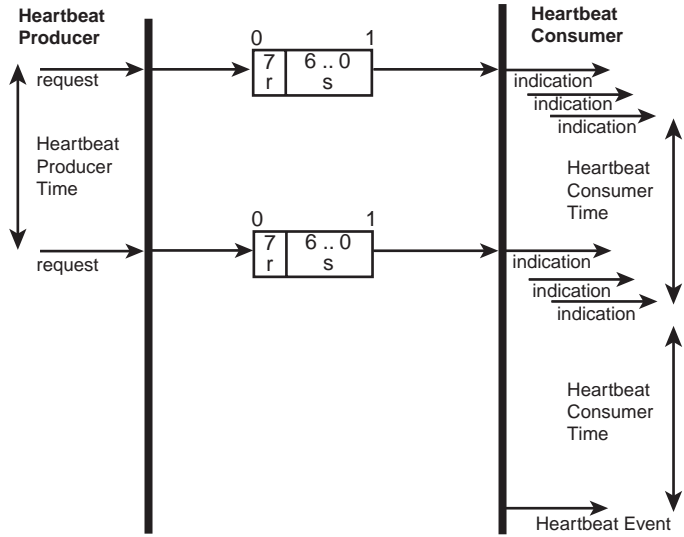


Fig. 3.24 Heartbeat Protocol

Wiring of connections

Transmission speed	Max. length of line over the entire net ¹⁾	
1000 kBaud	25 m	
800 kBaud	50 m	
500 kBaud	100 m	Factory setting
250 kBaud ²⁾	250 m	
125 kBaud ²⁾	500 m	
50 kBaud ³⁾	1000 m	
20 kBaud ³⁾	2500 m	
10 kBaud ³⁾	5000 m	
<p>1) Rounded bus length estimation (worst case) on basis 5 ns/m propagation delay and a total effective device internal in-out delay as follows: 1M-800 kbit/s: 210 ns 500 - 250 kbit/s: 300 ns (includes 2 * 40 ns for optocouplers) 125 kbit/s: 450 ns (includes 2 * 100 ns for optocouplers) 50 - 10 kbit/s: Effective delay = delay recessive to dominant plus dominant to recessive divided by two.</p> <p>2) For bus length greater than about 200 m the use of optocouplers is recommended. If optocouplers are placed between CAN Controller and transceiver this affects the maximum bus length depending upon the propagation delay of the optocouplers i.e. -4m per 10 ns propagation delay of employed optocoupler type.</p> <p>3) For bus length greater than about 1 km bridge or repeater devices may be needed.</p>		

Table 3.17 Transmission speeds



The CiA specification DR303-1 contains recommendations for wiring and the different connector plugs.

Electronic data sheet specification

EDS – Electronic Data Sheet

- The EDS-file contains device specific data and parameters (object directory) according to your type of data, the value range and the access attributes.
- Setup tools for CANopen networks use this file for the graphical visualization of the individual CANopen nodes.
- Available in the Internet together with any drive controller firmware.
- Generation with LUST-CANtool possible

DCF – Device Configuration File

- Description of the configured device
- Additional information about the parameter setting (object).

3.3.3 CANopen profiles

The following section deals with the CANopen profiles, which are available in the positioning control series CDE/CDB/CDF3000. File specifications for the profiles can be found in the current valid user manual for the positioning controls.

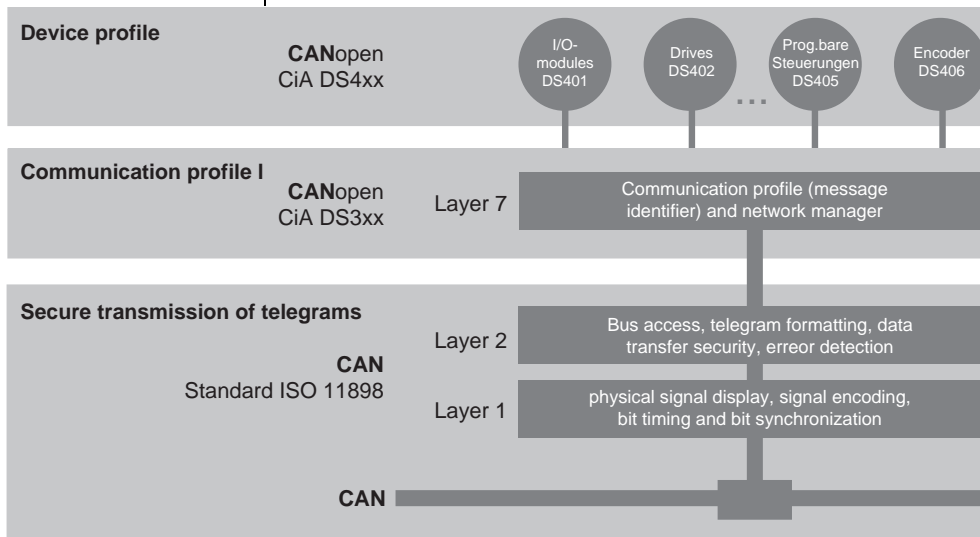


Fig. 3.25 CANopen structure

Device profile DS402

Goal of this profile is the provision of a similar description of the functionality of all drives, which are visible via CAN.

Follows the DRIVECOM-Profile 21 for drives and facilitates the use of already known profiles for manufacturers and users of such devices.

Due to the vast variety of specific properties implemented by the manufacturer of such devices, a uniform description method is required to be able to describe also manufacturer specific performance characteristics.

Replaceability of devices is possible, at least for standard tasks.

For drive manufacturers the availability of a standardized application profile means that an implementation of specific protocols is at least not required for each customer.

The device profile DS402 describes a drive in the following partial sections:

- General motor and drive data
- Device control
 - State machine (start control, quick stop)
 - Control of operating mode (e.g.: velocity mode)
- Specification of conversion variables
 - Factorgroups
- Parameters and control in the individual operating modes
 - Homing mode
 - Profile Velocity Mode
 - Profile Position Mode
 - Interpolated Position Mode

Device profile DS402, state machine

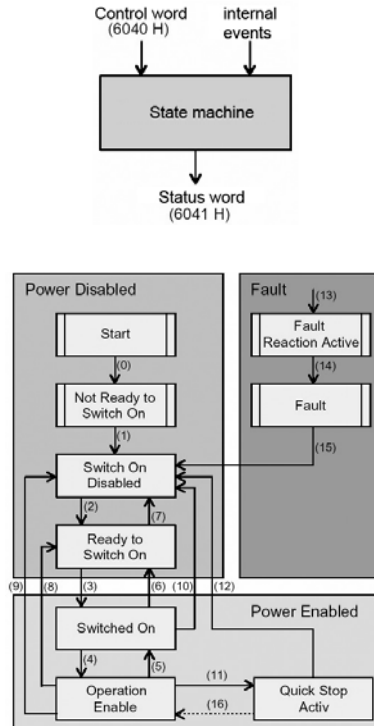


Fig. 3.26 Device profile DS402, state machine

Device profile DS402 control status word

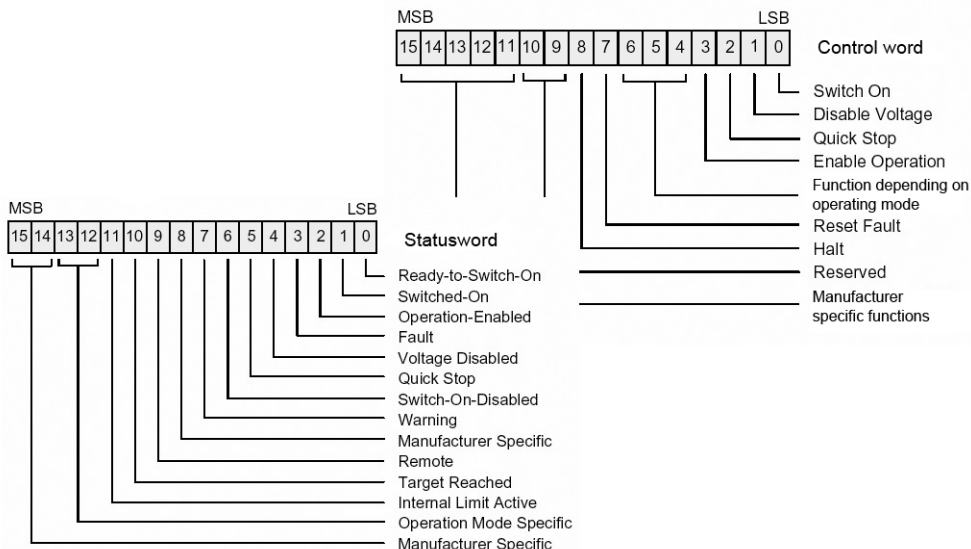


Fig. 3.27 Control status word

Device profile DS402 Factorgroup

- Control uses real physical units (e.g.: mm)
- The Factorgroup converts the SI-units into internal values
- Conversion takes place by specification of:
 - the physical unit
 - dimension and notation of this unit
 - Example: mm: = position_dimension_index =1
position_notation_index = -3
- equivalent factors do exist for velocity and acceleration
- specification entries do additionally exist
 - Encoder resolution
 - Transmission ratio

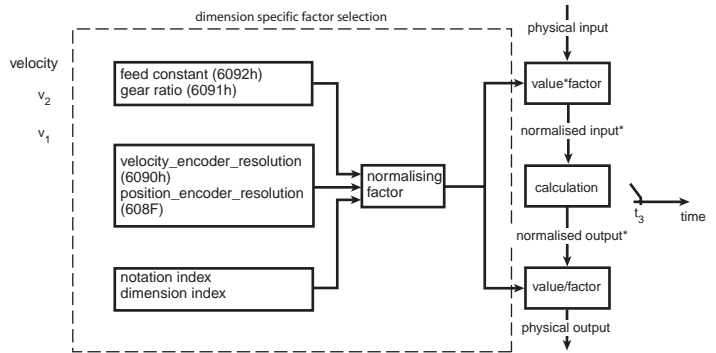


Fig. 3.28 Influence/use of objects from the Factorgroup

Index	Object	Name	Type	Attr.	M/O
6089 _h	VAR	Position notation index	INTEGER8	rw	0
608A _h	VAR	Position dimension index	UNSIGNED8	rw	0
608B _h	VAR	Velocity notation index	INTEGER8	rw	0
608C _h	VAR	Velocity dimension index	UNSIGNED8	rw	0
608D _h	VAR	Acceleration notation index	INTEGER8	rw	0
608E _h	VAR	Acceleration dimension index	UNSIGNED8	rw	0
608F _h	ARRAY	Position encoder resolution	UNSIGNED32	rw	0
6090 _h	ARRAY	Velocity encoder resolution	UNSIGNED32	rw	0
6091 _h	ARRAY	Gear ratio	UNSIGNED32	rw	0
6092 _h	ARRAY	Feed constant	UNSIGNED32	rw	0
6093 _h	ARRAY	Position factor	UNSIGNED32	rw	0
6094 _h	ARRAY	Velocity encoder factor	UNSIGNED32	rw	0
6095 _h	ARRAY	Velocity factor 1	UNSIGNED32	rw	0
6096 _h	ARRAY	Velocity factor 2	UNSIGNED32	rw	0
6097 _h	ARRAY	Acceleration factor	UNSIGNED32	rw	0
607E _h	VAR	Polarity	UNSIGNED8	rw	0

Table 3.18 Objects Factorgroup

- Object 6089_n: Position notation index
- Object 608A_n: Position dimension index
- Object 608B_n: Velocity notation index
- Object 608C_n: Velocity dimension index
- Object 608D_n: Acceleration notation index
- Object 608E_n: Acceleration dimension index ..
- Object 608F_n: Position encoder resolution
- Object 6090_n: Velocity encoder resolution
- Object 6091_n: Gear ratio
- Object 6092_n: Feed constant
- Object 6093_n: Position factor
- Object 6094_n: Velocity encoder factor
- Object 6095_n: Velocity factor 1
- Object 6096_n: Velocity factor 2
- Object 6097_n: Acceleration factor
- Object 607E_n: Polarity

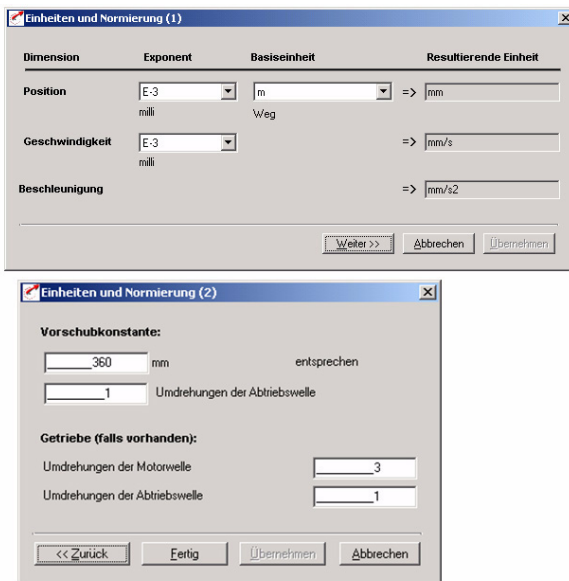


Fig. 3.29 Factorgroup and standardizing assistant in DRIVEMANAGER

Device profile DS402 Homing Mode

Objective of the Homing Mode is the occupation of a reference position with a fixed reference to machine or plant.

The profile specifies a vast variety (approx. 40) of referencing methods. These methods are selected via the object "homing_method".

- with evaluation of limit switches, index signals and encoder signals
- inherent parameters for velocity and acceleration
- the stop bit interrupts referencing

Object 607C_h: Home offset
Object 6098_h: Homing method
Object 6099_h: Homing speeds
Object 609A_h: Homing acceleration ...

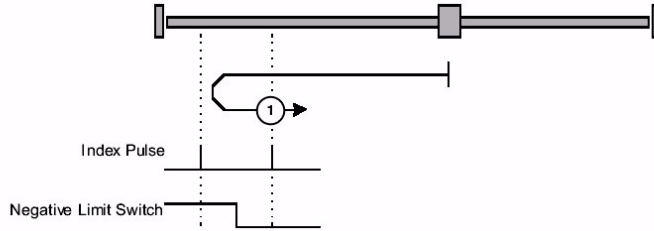
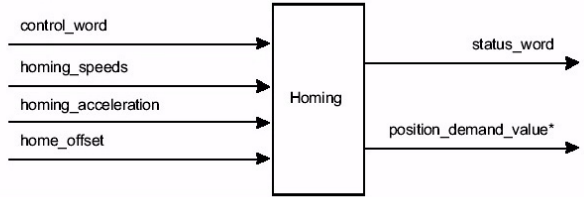


Fig. 3.30 Homing mode

Device profile DS402 Profile Position Mode

The device profile DS402 is the typical operating mode for drives. A comprehensive set of parameters sets the trajectory generator.

The most important specification is the target position (target_position), which is to be reached (relative or absolute) in compliance with travel velocity, acceleration and braking ramp. If a Factorgroup is available these specifications will automatically be converted.

- Single Setpoint: after braking the drive reports that the target position has been reached, a new target position can then be approached.
- Set of Setpoints: During the travel to the target position this position is overwritten by a new target position "change_Set_immediately".

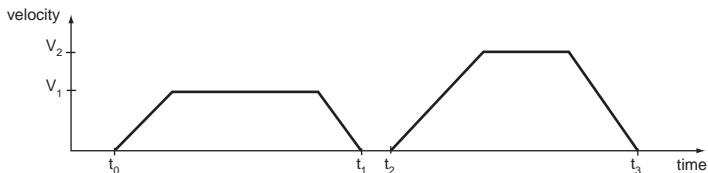


Fig. 3.31 Single set-point

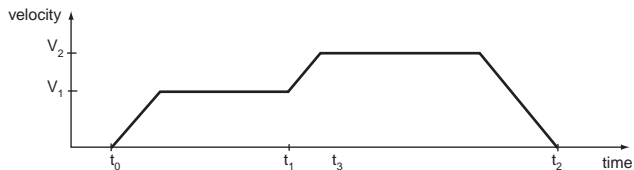


Fig. 3.32 Set of set-points

Index	Object	Name	Type	Attr.	M/O
607A _h	VAR	Target position	INTEGER32	rw	M
607B _h	ARRAY	Position range limit	INTEGER32	rw	0
607D _h	ARRAY	Software position limit	INTEGER32	rw	0
607F _h	VAR	Max. profile velocity	UNSIGNED32	rw	0

Table 3.19 Objects Profile Position Mode

Index	Object	Name	Type	Attr.	M/O
6080 _h	VAR	Max motor speed	UNSIGNED32	rw	0
6081 _h	VAR	Profile velocity	UNSIGNED32	rw	M
6082 _h	VAR	End velocity	UNSIGNED32	rw	0
6083 _h	VAR	Profile acceleration	UNSIGNED32	rw	M
6084 _h	VAR	Profile deceleration	UNSIGNED32	rw	0
6085 _h	VAR	Quick stop deceleration	UNSIGNED32	rw	0
6086 _h	VAR	Motion profile type	INTEGER16	rw	M
60C5 _h	VAR	Max acceleration	UNSIGNED32	rw	0
60C6 _h	VAR	Max deceleration	UNSIGNED32	rw	0

Table 3.19 Objects Profile Position Mode

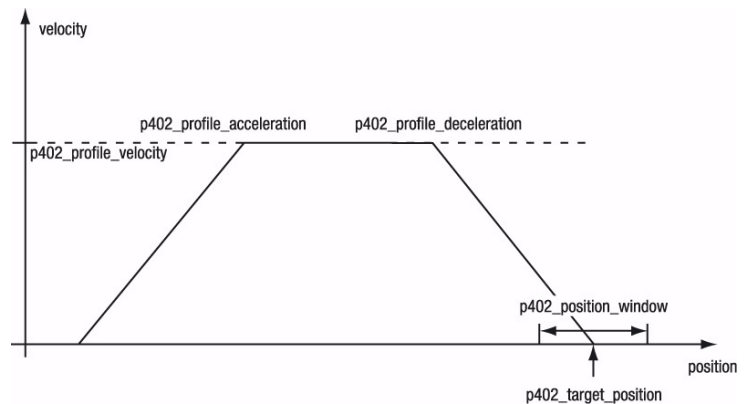


Fig. 3.33 Profile Position Mode

Device profile DS402 Profile Velocity Mode

- Generation of velocity specification by means of a trajectory generator.
- The axis accelerates with the parameterized value "profile_acceleration" up to max. velocity "target_velocity" and then continues travelling with this velocity.
- Target_velocity = 0 or stop bit brakes the drive.

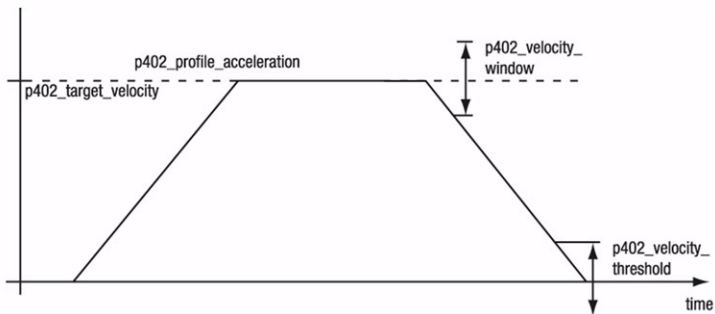


Fig. 3.34 Profile Velocity Mode

Index	Object	Name	Type	Attr.	M/O
6069 _h	VAR	Velocity sensor actual value	INTEGER32	ro	M
606A _h	VAR	Sensor selection code	INTEGER16	rw	0
606B _h	VAR	Velocity demand value	INTEGER32	ro	M
606C _h	VAR	Velocity actual value	INTEGER32	ro	M
606D _h	VAR	Velocity window	UNSIGNED16	rw	0
606E _h	VAR	Velocity window time	UNSIGNED16	rw	0
606F _h	VAR	Velocity threshold	UNSIGNED16	rw	0
6070 _h	VAR	Velocity threshold time	UNSIGNED16	rw	0
60FF _h	VAR	Target velocity	INTEGER32	rw	M
60F8 _h	VAR	Max slippage	INTEGER32	rw	0
60F9 _h	ARRAY	Velocity control parameter set	UNSIGNED16	rw	0

Table 3.20 Profile Velocity Mode

Device profile DS402 Interpolated Position Mode

The Interpolated Position Mode serves the control of several axes with coordinated position (legs of trajectory). The Sync-Service realizes the temporal synchronization of the axes.

If the drive has an input buffer, the position values can be written in burst method (currently not implemented).

The linear interpolation between the position values is the default method. For this purpose at least one position value needs to be stored.



c-line Drives do not have an implemented input buffer.

Example of movement of two axes

1. The initial situation is a leg of trajectory in the plane, which consists of individual points. Each point has an X and a Y coordinate, as well as a point in time, at which the position is to be reached.

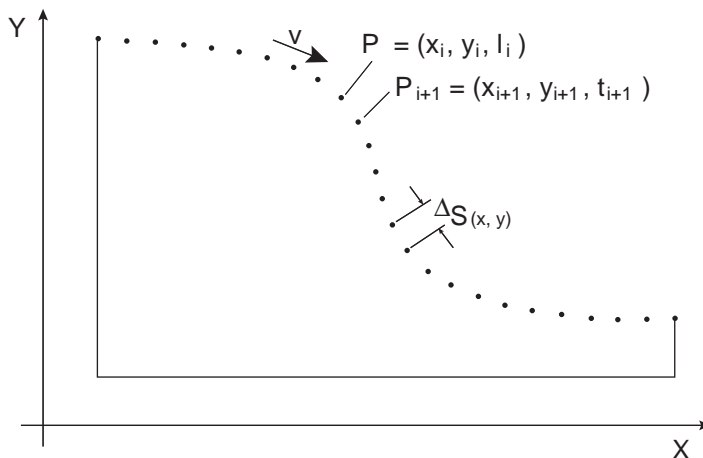


Fig. 3.35 Interpolation for two axes

- From the path curve target positions for each axis (X and Y) can be calculated, in dependence on the time.

calculated position	ip data records for	
	x-axis	y-axis
P_i	x_i, t_i	y_i, t_i
P_{i+1}	x_{i+1}, t_{i+1}	x_{i+1}, t_{i+1}
P_{i+2}	x_{i+2}, t_{i+2}	x_{i+2}, t_{i+2}
P_{i+3}	x_{i+3}, t_{i+3}	x_{i+3}, t_{i+3}
P_{i+n}	x_{i+n}, t_{i+n}	x_{i+n}, t_{i+n}

Table 3.21 Position calculation in interpolated position mode for several axes

- These calculated points are transmitted to the individual axes as "given interpolation positions" at the calculated points in time. Each axis thereby performs a tuned interpolation between the given interpolation positions, according to the set interpolation method. The tuned interpolation cycle results from the cycle of the positioning control.

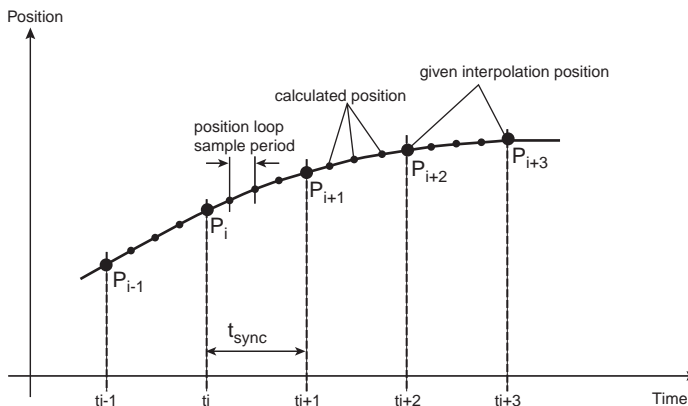


Fig. 3.36 Linear interpolation for one axis



Leg of trajectory: The leg of trajectory is calculated by a superordinate control. Absolute position values are transmitted to the drive control. The buffer depth is 1 (one).

The positioning controls CDE/CDB/CDF3000 are synchronized via Sync-Identifiers and perform a linear interpolation.

Index	Object	Name	Type	Attr.	M/O
60C0h	VAR	Interpolation sub mode select	INTEGER16	rw	0
60C1h	ARRAY	Interpolation data record	INTEGER32	rw	0
60C1h	RECORD	Interpolation time period	Interpolation time period record	rw	0
60C3h	ARRAY	Interpolation sync definition	UNSIGNED8	rw	0
60C4h	RECORD	Interpolation data configuration	Interpolation data configuration record	rw	0

Table 3.22 Objects Interpolated position mode



Further information on objects and their support by c-line drive controls can be found in the "User Manual CANopen Communication".

Interpolated Mode in the CDE/CDB/CDF3000 Firmware >V3.0

- Area of application: Multiple usage applications.
- Alternative to rated velocity specification $\pm 10V$ and encoder simulation.
- The most up-to-date firmware should always be used!
- Drive controls are only Slaves, which process the rated values from a Master!
- Calculation of the leg of trajectory only in the Master control.
- C-line buffer depth = 1
no input buffer for burst of rated positions, which are activated with Sync...
- Transmission of **absolute** rated values (rated position values).
- Currently **ONLY linear** Interpolation between the given interpolation positions from the control.
- Synchronization via Sync Identifier
Synchronization of the Task Discs (1ms Task) and thus synchronous processing of rated values.

Number of axes	Cycle / Busload	
	1000 kBit	500 kBit
1	1 ms / 29 %	2 ms / 29 %
2	1 ms / 52 %	2 ms / 52 %
3	2 ms / 38 %	3 ms / 50 %
4	2 ms / 49 %	3 ms / 66 %
5	2 ms / 61 %	4 ms / 61 %
6	2 ms / 73 %	4 ms / 73 %
7	3 ms / 56 %	5 ms / 67 %
8	3 ms / 64 %	5 ms / 77 %
9	3 ms / 72 %	6 ms / 72 %
10	3 ms / 79 %	6 ms / 79 %

Table 3.23 *Typical capacity*

Attention: Capacity
 Cycle times > 5ms should be avoided!!!
 Busload of approx. 60% still acceptable

Application example printing machine

- Four-colour press with synchronization via CANopen Interpolated Position Mode.
- Trio control as Maser
 Δt of Slaves to 2 CAN Masters
 short cycle times with acceptable busload possible.
- Five axes with CDE3000 and LSH motors
 four colours and one axle for feed
 high-resolution SSI sensor in use.
- All five axes are coordinated via Interpolated Position Mode.

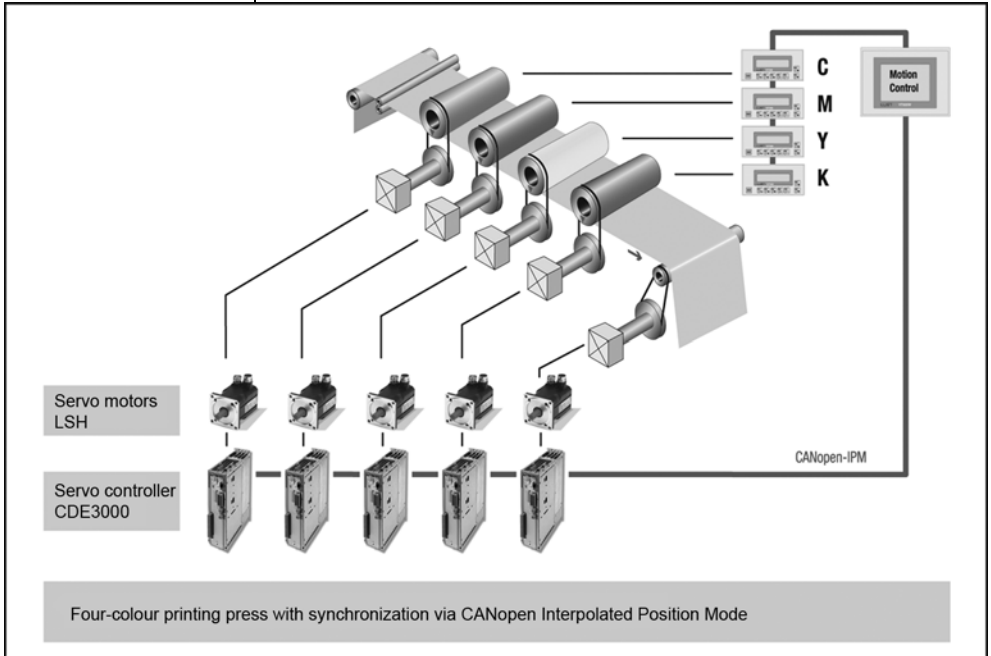


Fig. 3.37 Application example four-colour press

Controls for interpolated position mode

With the following controls the CDE3000 can be operated in Interpolated Position Mode:

Company	Control type
Bachmann electronic GmbH Kreuzäckerweg 33 A-6800 Feldkirch Phone +43 (0)55 22 / 34 97-0 Fax +43 (0)55 22 / 34 97-102	MPC270 with CM202
ECKELMANN AG Berliner Straße 161 65205 Wiesbaden Phone: +49 (0) 611 - 7103-0 Fax: +49 (0) 611 - 7103-133 email: info@eckelmann.de	E-ENC 55
Trio Motion Technology Shannon Way, Tewkesbury, Gloucestershire, GL20 8ND United Kingdom Phone: +44 1684 292333 Fax: +44 1684 297929	MC206

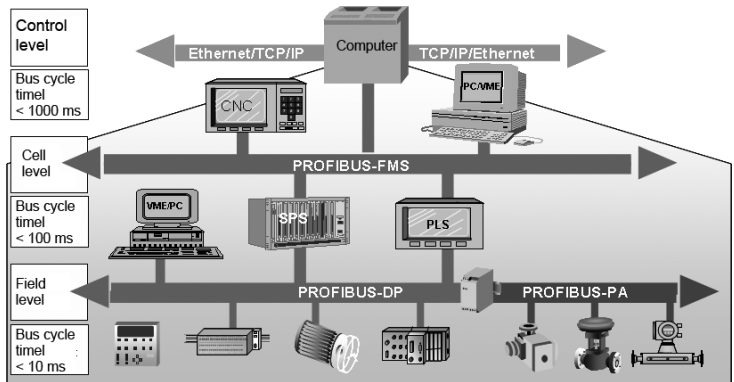
Table 3.24 Controls for interpolated position mode

- Bachmann MP2xx one CPU module
CPU modules with integrated CAN-interface are available
A CAN Master module CM202 can alternatively be used
- Eckelmann E-ENC 55 is a top hat rail PC with integrated CAN-interface
- Trio Motion MC206 is a control with integrated CAN-interface

3.3.4 PROFIBUS-DP Basics

Overview

Transparent communication from sensor / actor to master level.



The PROFIBUS family

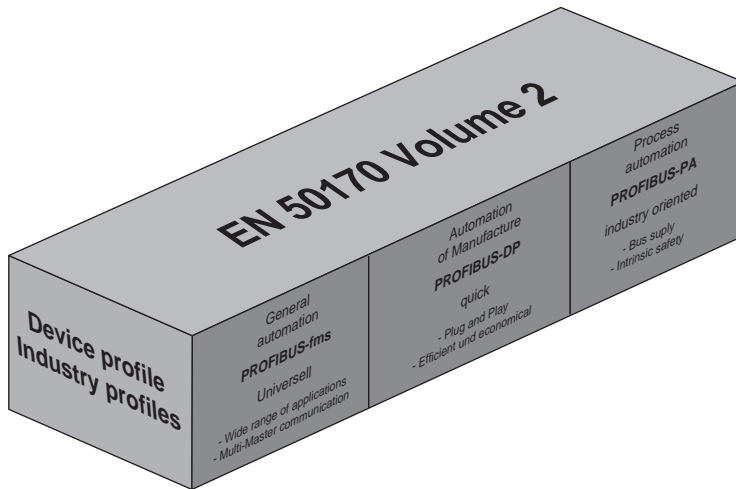
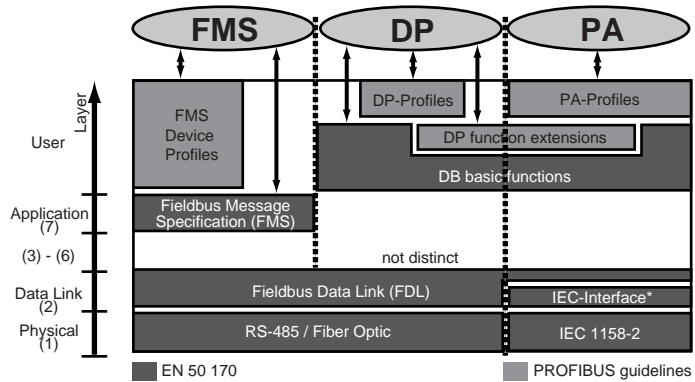


Fig. 3.38 PROFIBUS family

The PROFIBUS protocol meets the requirements of the ISO/OSI reference model for open systems



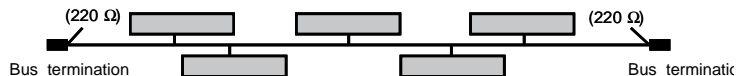
* The integration as appendix 2 to EN 50170 volume 2 has been applied for.

Fig. 3.39 PROFIBUS in the ISO/OSI reference model

Transmission technology

Features of the transmission technology

- High Speed RS 485 (H2)
 - Baud rates of 9.6 kBit/s to 12 MBit/s, selectable in stages
 - Screened, twisted two-strand cable
 - 32 stations per segment, max. 127 stations permitted (Master and Slaves)
 - Bus lengths depending on baud rate
 - 12 MBit/s = 100 m; 1.5 MBit/s = 400m; ≤ 187.5 kBit/s = 1000 m
 - With the use of repeaters (max. 10 units) the bus length can be extended to 10 km
 - 9 PIN, D-Sub plug connector (special plug)
 - The bus topology enables coupling and decoupling of stations during operation, without any conducted interference to the overall system.



Features of the transmission technology

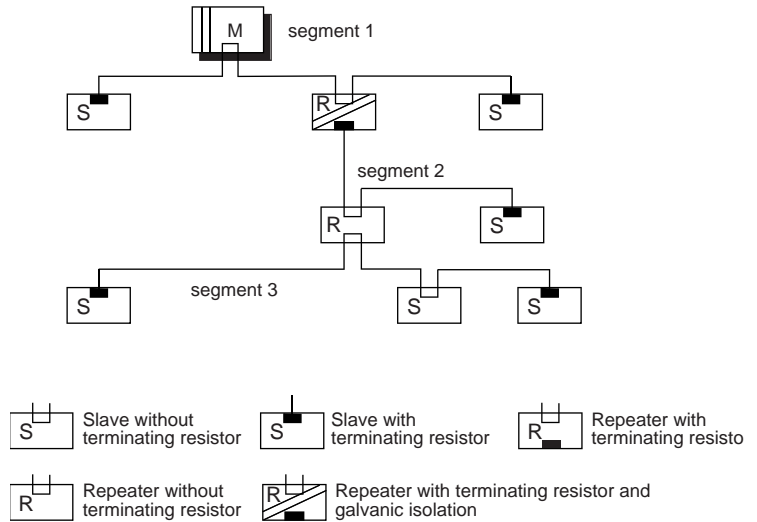


Fig. 3.40 Segmentation of a PROFIBUS system

- Maximum 32 subscribers per segment
- Up to 10 segments in line possible
- Consider baud rate dependent max. extension of bus

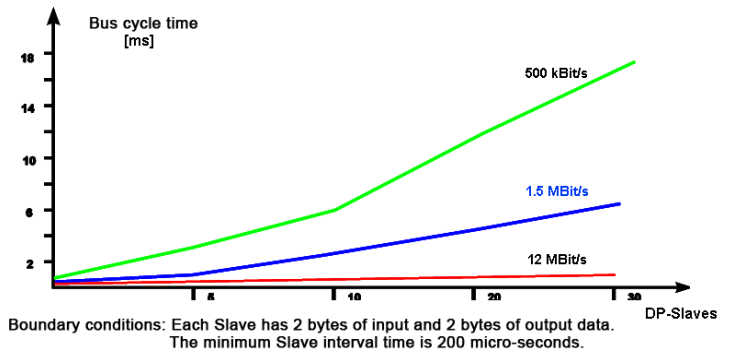


Fig. 3.41 Bus cycle time of a PROFIBUS-DP Mono-Master System

Boundary conditions:

Each Slave has 2 Byte input and 2 Byte output data.
 The minimum Slave interval time is 200 micro-seconds

Communication technology

PROFIBUS uses the Master/Slave method.
 The Slaves are sequentially and cyclically addressed by the Master.

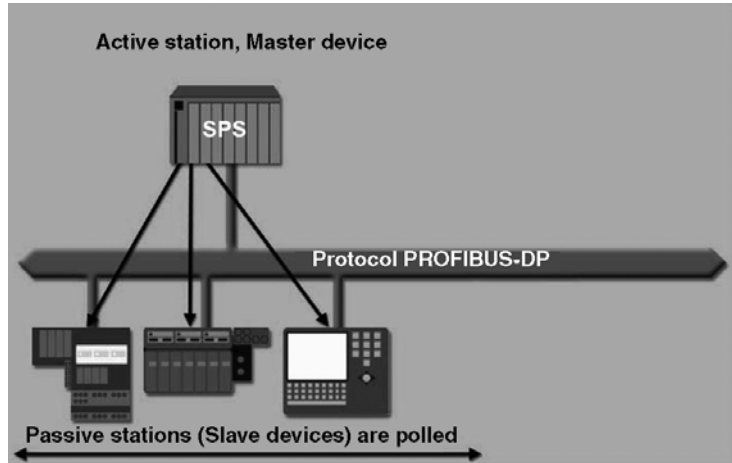


Fig. 3.42 Protocol PROFIBUS DP

Master/Slave principle of PROFIBUS

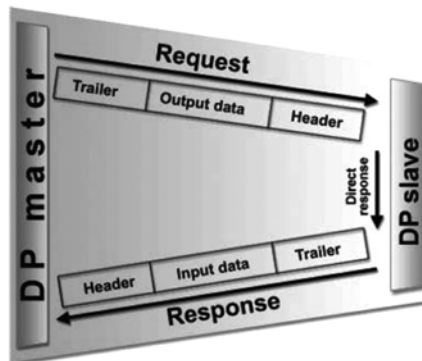


Fig. 3.43 Master/Slave principle

Each PROFIBUS-System is equipped with at least one Master. Maximum 127 devices (Masters and Slaves) can be used in a system. It is also possible to integrate several Masters into one system.

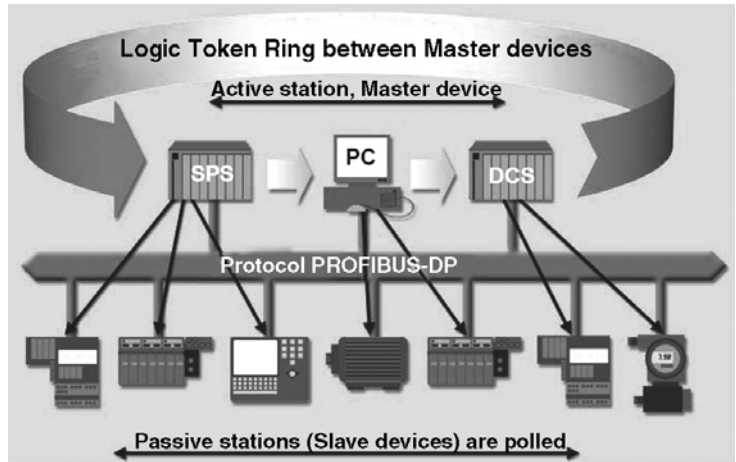


Fig. 3.44 Token ring



Attention: Token and multi-master operation

The Token determines which Master shall have access to the bus and the Slaves. For reasons of safety communication is only possible between one Master and the Slaves assigned to it. I. e. a Slave can **never** receive rated values from different Masters.

The communication protocol PROFIBUS DP

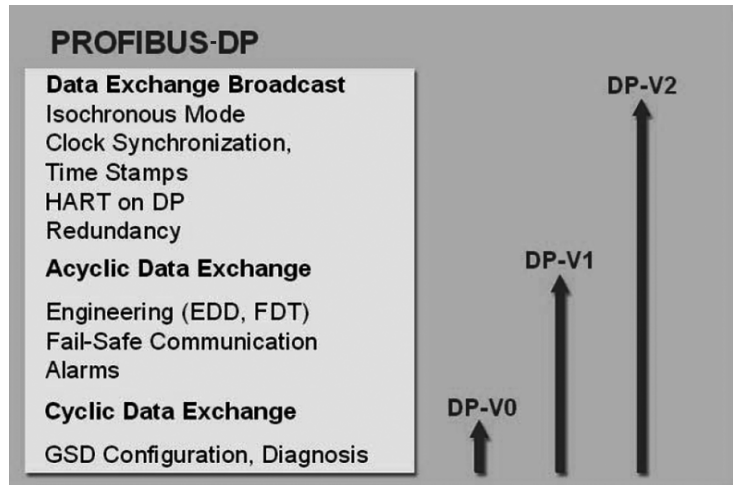


Fig. 3.45 Staggered scope of functions of Profibus-DP



The c-line drive controls use the communication protocol DP-VO. The acyclic data exchange (DP-V1) is under preparation.

Communication with drive controls for C-line-Drives

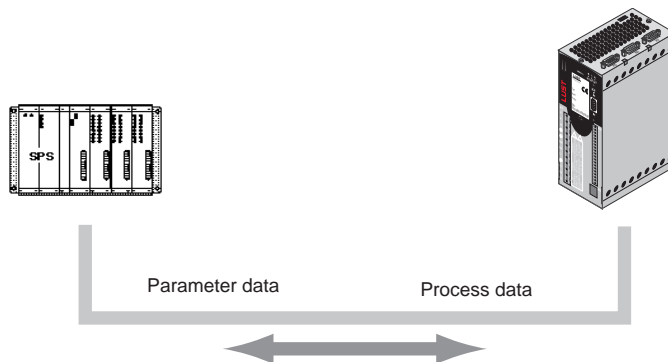


Fig. 3.46 Data exchange

- Parameter channel
 - Parameterization of drive devices
 - Reading out parameters, e.g. error code
- Process data channel
 - Transfer of control and status word
 - Transfer of rated and actual values (velocity, position)

PROFIBUS-DP - device types

DP-Master class 1 (DPM1)

Central control, which communicates with the decentralized I/Os (DP-Slaves).

Several DPM1 in an interconnected network are permitted, typical devices are PLC, PC, VME

DP-Master class 2 (DPM2)

A DPM2 is a projecting, monitoring or engineering tool for commissioning or parameterizing/monitoring the DP-Slaves.

DP-Slave

The DP-Slave is the decentralized device with direct interface to the input/output signals. Typical devices are I/Os, drives, valves, control units.

Profiles of c-line drive controls

- Use of EasyDrive profiles
 - EasyDrive "Basic" for velocity control
 - EasyDrive "DirectPos" for positioning with profile specification via bus and jog mode
 - EasyDrive "TablePos" for positioning with control of device integrated travel set table and jog mode
 - EasyDrive "ProgPos" for velocity control or positioning with control of sequence program and jog mode
- PROFIDRIVE profile **only** for CDA/CDD3000
 - PROFIDRIVE state machine
 - Use in velocity controlled applications
 - Various rated/actual formats (16/16, 32/32, 32/2x16)



Profiles of c-line drive controls: Details to the profiles can be found in the corresponding user manual "PROFIBUS-DP".

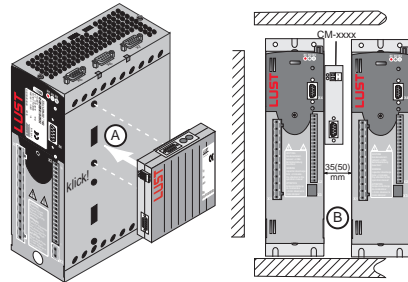
3.3.5 Commissioning of drive controls on PROFIBUS/S7

1.

Assignment of the PROFIBUS address, either at the PROFIBUS option, or in the drive control software. If the software address is unequal zero, it has priority. Addresses between 1 and 126 can be assigned.

2.

Assembly of the PROFIBUS option CM-DPV1 to the drive control, in the top slot. It is important to check the position of the jumpers on the module (for conversion BG6 to BG8).



3.

The PROFIBUS is connected by means of standardized plugs and cables. The correct combination is highly important. Use cables with rigid copper core in plugs with IDC-method of termination and cables with copper strand in screw plugs, as otherwise interferences may occur at high transmission rates.

The PROFIBUS cable is looped through from subscriber (Slave) to subscriber. Each end of the PROFIBUS must be terminated with a terminating resistor. In conventional standard plugs these can be enabled with a switch.

4.

Supply the PROFIBUS option with external 24 V, do not use the internal voltage of the drive control.

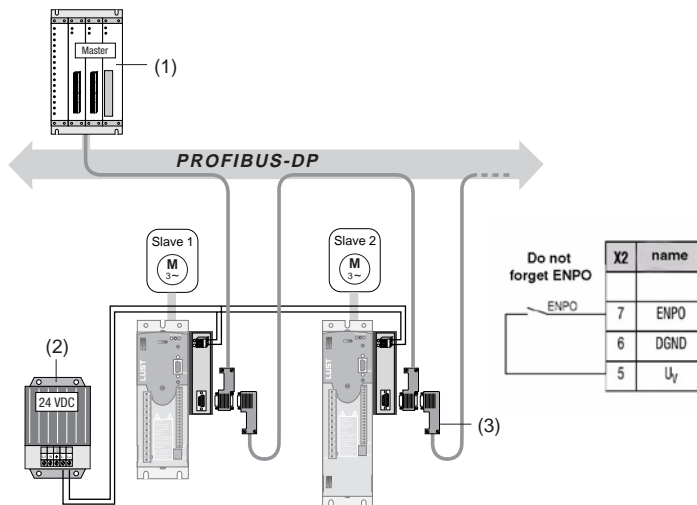


Fig. 3.47 PROFIBUS networking with 24V supply voltage



Wiring of control terminals: Depending on the drive control design the ENPO (control release) or the ISDSH (safe stop) must be activated (wired).

5.

Parameterize the drive control as required by the application. It is thereby important to make sure that the default solution with field bus is selected.



Information on parameterization can be found in the user manual for the corresponding drive control.

6.

Configuration of S7

S7 is a programmable logic control (PLC), normally with integrated PROFIBUS. It is the Master in the bus network. The PROFIBUS performs the data exchange acc. to the Master/Slave principle, i.e. the Slave is addressed by the Master successively in cycles. For this purpose the Master needs some information on each Slave. These are integrated in the hardware configuration through the GSD-file.

The GSD-file can be considered as a data sheet. It contains e.g. information on manufacturer, software status, hardware status, transmission speed, supported services, possible diagnostics, etc..

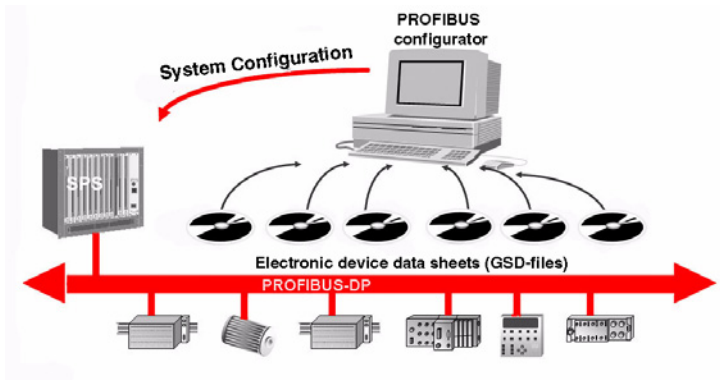
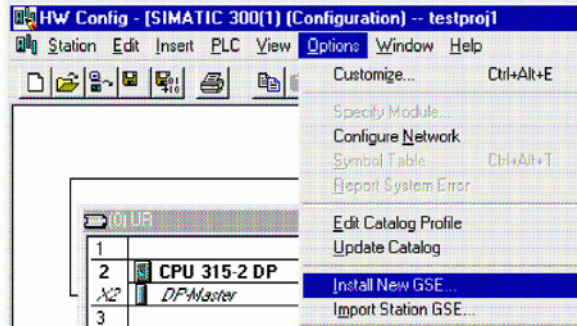


Fig. 3.48 Configuration with GSD-file



Note: The GSD for device integration is fully sufficient for the exchange of measuring values and control variables between field device and automation system.

Integration of the GSD-file into the S7 hardware configuration.
 The GSD-file is added under the menu option "install new GSD-file". The GSD-file is named LUXX0564.GSD (XX index for release).



The GSD-file can be found in the Download area on the Homepage of LUST Antriebstechnik.

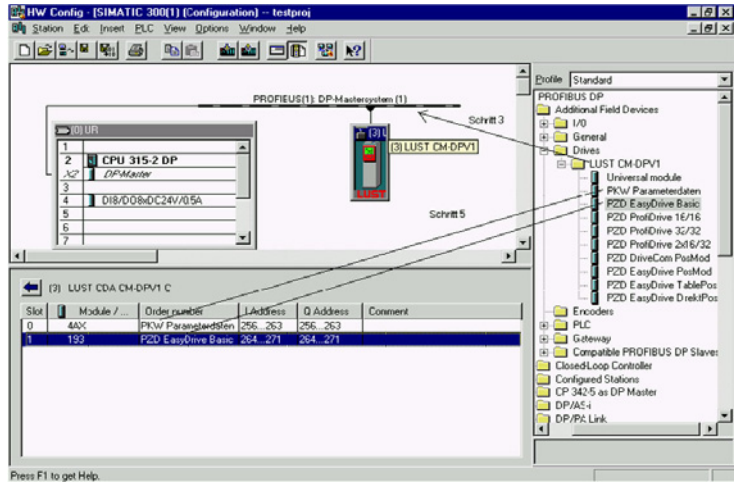


Attention: Select the GSD-file in dependence on the drive control and the module software used by you.

7.

Connecting the module to the PROFIBUS.

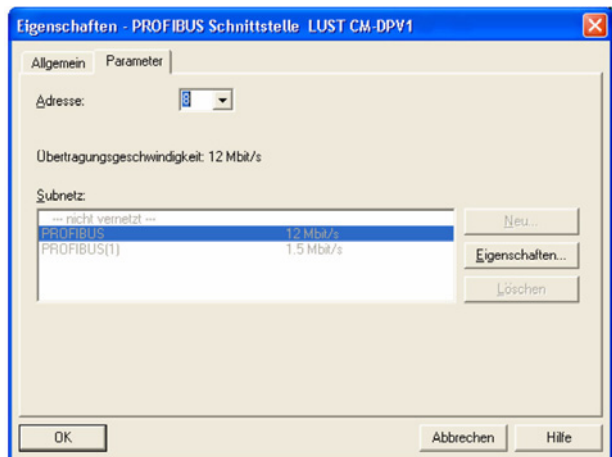
The section rail and the S7 must be integrated in the hardware configuration. This can be simply drawn from the catalogue on the left hand side into the middle window. After successful implementation of the GDS-file you can find it in the catalogue under: PROFIBUS DP -> Other field devices -> Drives -> Lust CM-DPV1 V2.00. This module is then linked to the PROFIBUS.



8.

Assignment of the PROFIBUS address in the hardware configuration.

When linking the module to the PROFIBUS, the following window is automatically displayed. Under "Address" set the adjusted address of the drive control.



9.

In the module the PKW parameter data mode must be entered in "Slot 0" and the parameterized Easy Drive mode in "Slot 1". The exchange of parameters and data uses this implemented modules during later cyclic operation.

10.

Saving and loading configuration of S7.

11.

After switching on S7 and drive control with optional module, this will, after successful parameterization, change to cyclic data transfer. The green LED lights up.

12.

Now programming of the S7 can be started. There the data exchange with the Slave must be set up via SFC 14 and SFC 15.



Simple examples for the initial exchange of data can be found on the Homepage. These program samples contain a table of variables. This list can be opened in the Simatic in the opened project inside the left hand column under "Project name" -> Simatic -> CPU -> S7 Program -> modules. This table of variables enables to send of the control word of the drive control and to receive the status word. Any other programming is left to the PLC programmer.



Further information and documents

Further information can be found on the Homepage of the PROFIBUS user organization (PNO): <http://www.profibus.de>

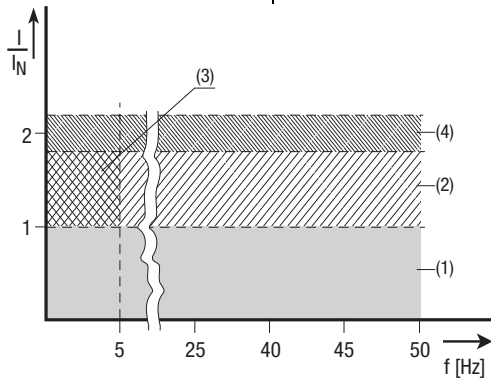
such as e. g.

- PROFIBUS basics and overview
 - Downloads (e.g. specifications), partly access only with subscriber login
 - Web-based training (<http://www.profibus.com/wbt/index2.html>)
-

3.4 c-line drive controller system CDA3000

3.4.1 Current capacity of drive controllers CDA3000

The maximum permissible drive controller output current and the peak current are dependent on the mains voltage, the motor cable length, the power stage switching frequency and the ambient temperature. If the conditions change, the maximum permissible current capacity of the drive controllers also changes. Refer to the following graphs and tables.



*Intermittent $I_N > I_{eff}$

$$I_{eff} = \sqrt{\frac{1}{T} \cdot \sum_{i=1}^n I_i^2 \cdot t_i}$$

- (1) **Continuous operation**
- (2) **Intermittent operation* > 5 Hz Rotating field frequency**
 Drive controllers 0.37 to 15 kW
 $I/I_N = 1.8$ (for 30 s at 4 kHz)
 $I/I_N = 1.8$ (for 30 s at 8 kHz)
 $I/I_N = 1.8$ (for 30 s at 16 kHz)
 Drive controllers 22 to 90 kW
 $I/I_N = 1.5$ (for 60 s at 4 kHz)
 $I/I_N = 1.5$ (for 60 s at 8 kHz)
- (3) **Intermittent* 0 to 5 Hz rotating field frequency**
 Drive controllers 0.37 to 15 kW
 $I/I_N = 1.8$ (for 30 s at 4 kHz)
 $I/I_N = 1.25-1.8$ (for 30 s at 8 kHz)
 Drive controllers 22 to 90 kW
 $I/I_N = 1.5$ (for 60 s at 4 kHz)
 $I/I_N = 1-1.5$ (for 60 s at 8 kHz)
- (4) **Pulse mode**
 Drive controllers 0.37 to 15 kW
 $I/I_N = \text{approx. } 2.2$ (at 4, 8, 16 kHz)
 Drive controllers 22 to 90 kW
 $I/I_N = \text{approx. } 1.8$ (at 4, 8 kHz)

Drive controllers for 230 V systems

Drive controller	Rec. 4-pole standard motor [kW]	Switching frequency of power stage [kHz]	Rated current [A]	Peak current for intermittent mode 0 to 5 Hz [A]	Peak current for intermittent mode > 5 Hz [A]	Max. cooling temperature/ rated current 230 V [°C, A]
CDA32,004.Cx.x ¹⁾	0.75	4	4	7.2	7.2	55, 3.3
		8	4	7.2	7.2	55, 2.8
		16	3	5.4	5.4	55, 2.2
CDA32,006.Cx.x ¹⁾	1.1	4	5.5	9.9	9.9	55, 4.9
		8	5.5	9.9	9.9	55, 4.1
		16	4.3	7.7	7.7	55, 3.1

Table 3.25 Drive controllers for 230 V systems

Drive controller	Rec. 4-pole standard motor [kW]	Switching frequency of power stage [kHz]	Rated current [A]	Peak current for intermittent mode 0 to 5 Hz [A]	Peak current for intermittent mode > 5 Hz [A]	Max. cooling temperature/ rated current 230 V [°C, A]
CDA32,008.Cx.x ¹⁾	1.5	4 8 16	7.1 7.1 5.5	12.8 12.8 8	12.8 12.8 9.9	55, 6.1 55, 5.4 55, 4.2
Peak current for 30 s with drive controller 0.75 to 15 kW Cooling air temperature: 45 °C at power stage switching frequency 4 kHz 40 °C at power stage switching frequency 8, 16 kHz 1) With heat sink HS3... or additional cooling surface				Mains voltage 1 x 230 V -20 % +15 % Motor cable length 10 m Mounting height 1000 m above MSL End-to-end mounting		

Table 3.25 Drive controllers for 230 V systems

Drive controllers for 400/460 V systems:

Drive controller	Rec. 4-pole standard motor [kW]	Switching frequency of power stage [kHz]	Rated current I _N [A] at 400 V ²⁾	Rated current I _N [A] at 460 V ³⁾	Peak current for intermittent mode 0 to 5 Hz [A]	Peak current for intermittent mode > 5 Hz [A]	Max. cooling temperature/ rated current 400/460 V [°C, A/A]
CDA34,003.Cx.x	0.75	4 8 16	2.2 2.2 1.0	2.2 2.2 1.0	4 4 1.1	4 4 1.8	55, 2.2/2.2 55, 1.3/1.25 40, 1.0/1.0
CDA34,005.Cx.x ¹⁾	1.5	4 8 16	4.1 4.1 2.4	4.1 3.6 -	7.4 7.4 4.3	7.4 7.4 4.3	55, 3.2/3.2 55, 2.6/2 -, -
CDA34,006.Cx.x ¹⁾	2.2	4 8 16	5.7 5.7 2.6	5.7 5.7 -	10.3 10.3 4.7	10.3 10.3 4.7	55, 5.1/5.1 55, 4.7/4.7 -, -
CDA34,008.Wx.x	3.0	4 8 16	7.8 7.8 5	7.8 7.8 -	14 14 7.8	14 14 9	55, 7.8/7.5 55, 7.0/6.2 55, 4.4/-
CDA34,010.Wx.x	4.0	4 8 16	10 10 6.2	10 8.8 -	18 16.5 7.8	18 18 11	55, 8.2/7.5 55, 7.0/6.2 55, 4.4/-
CDA34,014.Wx.x	5.5	4 8 16	14 14 6.6	14 12.2 -	25 21 9.2	25 21 11.9	55, 13/12 55, 10/7 55, 3/-

Table 3.26 Drive controllers for 400/460 V systems

Drive controller	Rec. 4-pole standard motor [kW]	Switching frequency of power stage [kHz]	Rated current I_N [A] at 400 V ²⁾	Rated current I_N [A] at 460 V ³⁾	Peak current for intermittent mode 0 to 5 Hz [A]	Peak current for intermittent mode > 5 Hz [A]	Max. cooling temperature/ rated current 400/460 V [°C, A/A]
CDA34,017.Wx.x	7.5	4 8 16	17 17 8	17 13.5 -	31 21.2 9,2	31 31 14.4	55, 14/14 55, 11/8 55, 4/-
CDA34,024.Wx.x	11	4 8 16	24 24 15	24 24 -	43 40 22	43 43 27	55, 23/22 55, 20/17 55, 13/-
CDA34,032.Wx.x	15	4 8 16	32 32 20	32 28 -	58 40 22	58 58 36	55, 25/25 55, 21/18 55, 14/-
CDA34,045.Wx.x	22	4 8	45 45	45 39	68 54	68 68	50, 33,7/33,7 50, 33,7/29
CDA34,060.Wx.x	30	4 8	60 60	60 52	90 71	90 90	50, 45/39 50, 45/39
CDA34,072.Wx.x	37	4 8	72 72	72 62	112 78	112 112	50, 54/54 50, 54/47
CDA34,090.Wx.x	45	4 8	90 90	90 78	135 104	135 135	50, 67.5/67.5 50, 67.5/58
CDA34,110.Wx.x	55	4 8	110 110	110 96	165 110	165 165	50, 82/82 50, 82/72
CDA34,143.Wx.x	75	4 8	143 143	143 124	215 143	215 215	50, 107/107 50, 107/93
CDA34,170.Wx.x	90	4 8	170 170	170 147	255 212	255 255	50, 127/127 50, 127/110
CDA34,250.Wx.x	132	4	250	250	255	300	-
Peak current for 30 s with inverter modules 0.37 to 15 kW Peak current for 60 s with inverter modules 22 to 132 kW Cooling air temperature: 45 °C at power stage switching frequency 4 kHz (up to CDA34,032) 40 °C at power stage switching frequency 8, 16 kHz (up to CDA34,032) 40 °C at power stage switching frequency 4 kHz (from CDA34,045)						2) Mains voltage 3 x 400 V ±10 % 3) Mains voltage 3 x 460 V ±10 % Motor cable length 10 m Mounting height 1000 m above MSL End-to-end mounting	
1) With heat sink HS3... or additional cooling surface							

Table 3.26 Drive controllers for 400/460 V systems

3.4.2 Project planning for three-phase AC motors

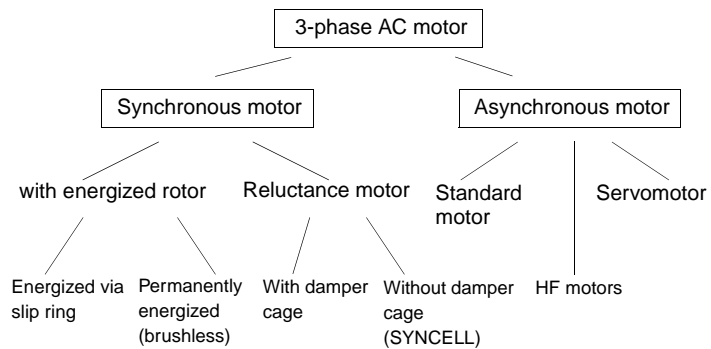
A wide variety of three-phase AC motors can be run on the drive controller system. Three-phase AC motors are manufactured in synchronous and asynchronous design versions. The stator winding is designed such that, when in service in a three-phase AC system, a rotating field is created in the motor which drives the rotor. The rotation speed is determined by the following variables:

$$n_s = \frac{f \cdot 60}{P}$$

n_s = synchronous speed
 P = number of pole pairs
 f = stator frequency

The motor type is determined by the rotor introduced into the rotating field.

Overview of three-phase AC motors



Areas of application for three-phase AC motors

Motor type	Working principle	Application
Standard three-phase AC motor	Asynchronous	In all industrial sectors. Around 10-25 % of all motors are speed-variable via drive controllers.
Synchronous motor with damper cage	Synchronous	In the textile industry for: spoolers, viscose pumps, galette drives, roller motors etc. Further areas of application are in the glass and paper industry as winding drives, etc.
Reluctance motor	Asynchronous/ Synchronous	In the textile industry for: spoolers, viscose pumps, galette drives, roller motors etc. Further areas of application are in drafting equipment and for synchronous running of two axles.
High-frequency motor	Asynchronous	In the timber processing industry as the main drive. Further areas of application are grinding and milling spindles, centrifuges, vacuum pumps and winders.
Asynchronous servomotor	Asynchronous	In the packaging and food industries as a clock and positioning drive. Further applications as the main drive for machine tools.
Displacement-type armature motor	Asynchronous with motor brake	In conveyor systems as a traction and lifting motor.

Table 3.27 Areas of application for three-phase AC motors

Project planning notes for three-phase AC motors

Motor type	Project planning notes
Standard three-phase AC motor	Section 2.5.1
Asynchronous servomotor	Section 2.5.2
Displacement-type armature motor	In a displacement-type armature motor the brake is ventilated by the magnetic field of the motor. The motor must always be run with the VFC control method. The "Current injection" software function must be adapted. Note: A high current flows when the motor is idling. Operation at low speeds is only permissible for short periods of time.
Reluctance motor	The reluctance motor is a special motor which must be tested anew prior to every production deployment (see section 2.3.1).
Synchronous motor with damper cage	The synchronous motor is likewise a special motor which must be tested anew prior to every production deployment (see section 2.3.2).
High-frequency motors (HF motors)	HF motors are usually run with constant torque, at high frequencies up to 1600 Hz. For more information see section 2.3.3.

Table 3.28 Project planning notes for synchronous and asynchronous three-phase AC motors

3.4.3 Efficiency of the motor control methods of the CDA3000

During commissioning of the drive controller three different control methods can be selected. The asynchronous motor is identified automatically by the drive controller based on the "plug-and-play" principle. All control loops are optimized in the process.

Voltage Frequency Control (VFC)

With VFC the voltage of the motor is modified proportional to the output frequency of the drive controller. This method is particularly suitable for reluctance motors, synchronous motors and special motors.

Sensorless Flux Control (SFC)

The new control method SFC, applicable to asynchronous motors, calculates the rotor speed and the current angle of the rotor from the electrical variables. Based on the calculated information, the currents to form the torque can be fed into the motor in a favourable way. In this way, outstanding control characteristics are attained even without the use of a cost-intensive encoder.

Field-Oriented Regulation (FOR)

In FOR the rotor and speed positions are ascertained with an encoder. Based on those measurement variables, the flux- and torque-forming currents can always be fed into the motor in optimum positions relative to each other. This produces maximum dynamics and smoothness.

General characteristics of the motor control methods	VFC Voltage Frequency Control	SFC Sensorless Flux Control	FOR Field Oriented Regulation
Torque rise time	approx. 10 ms	<2 ms	< 2ms
Dynamic disturbance correction	NO	YES	YES
Standstill torque	NO	NO	YES
Correction time for a load surge of $1 \times M_N$	<100 ms	<100 ms	<100 ms
Anti-stall protection	Limited	YES	YES
Speed manipulating range $M_{Const.}$	1:20	1:50	>1:10000
Static speed accuracy n/n_N	<2 %	<1 %	Quartz-accurate
Frequency resolution	0.01 Hz	0.0625 Hz	2^{-16} Hz

Table 3.29 Efficiency of the motor control methods with standard three-phase AC motor

General characteristics of the motor control methods	VFC Voltage Frequency Control	SFC Sensorless Flux Control	FOR Field Oriented Regulation
Motor principle	Asynchronous Synchronous Reluctance	Asynchronous	Asynchronous
Multi-motor operation	Yes	No	No
Encoder evaluation	No	No	Yes

Table 3.29 Efficiency of the motor control methods with standard three-phase AC motor



SFC: The SFC motor control method for the first time provides an optimal drive solution for machines such as ...

- Dispersers
- Document shredders
- Meat cutters and mincers
- Shredders
- Reducing machines
- Industrial coffee mills
- Breakers
- Mills. etc.

Break-away and acceleration torques dependent on motor control method

Characteristic	VFC Voltage Frequency Control	SFC Sensorless Flux Control	FOR Field Oriented Regulation
Break-away torque ¹⁾ with standard motor ($U_N = 400\text{ V}$)	$1.6 \times M_N$	$1.8 \times M_N$	$2 \times M_N$
Break-away torque ¹⁾ with asynchronous servomotor ($U_N = 330\text{ V}$)	$2.5 \times M_N$	$2.6 \times M_N$	$2.8 \times M_N$
Acceleration torque ¹⁾ with standard motor ($U_N = 400\text{ V}$)	$1.2 \times M_N$	$1.8 \times M_N$	$2 \times M_N$
Acceleration torque ¹⁾ with asynchronous servomotor ($U_N = 330\text{ V}$)	$1.6 \times M_N$	$1.8 \times M_N$	$2 \times M_N$
¹⁾ $I_{\text{Drive controller}} = 2 \times I_{\text{Motor}}$			

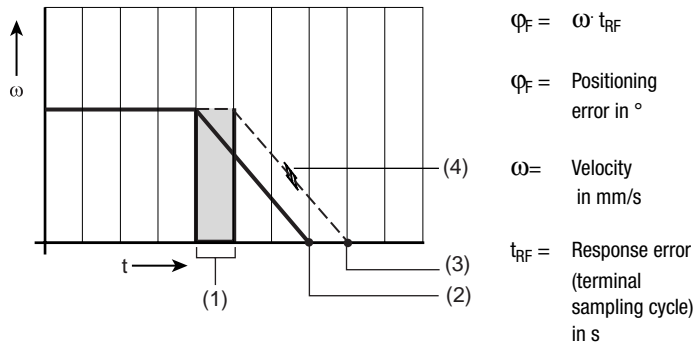
Table 3.30 Break-away and acceleration torques

The table above indicates what typical torque is available on the motor shaft of an asynchronous machine when the machine is driven by a CDA3000 drive controller. The maximum rated motor current is limited by the drive controller to $2 \times I_{N\text{-Motor}}$.



For data relating to the asynchronous servomotors refer to section 2.2.2.

Positioning accuracy with Start/Stop operation (without encoder feedback) as a function of motor control method



- (1) Sampling cycle of control terminals (CDA3000 = 1 ms) on drive controller (t_{RF} =response error)
- (2) Target position 1 (stop signal comes together with read-in of control signals on drive controller)
- (3) Target position 2 (stop signal comes directly after read-in of control signals on drive controller)
- (4) Slip range (depending on control mode the braking ramp is slip-dependent)

Figure 3.49 Start/Stop positioning

Characteristic	VFC Voltage Frequency Control	SFC Sensorless Flux Control	FOR Field Oriented Regulation
Braking time 100 ms, external moment of inertia = motor moment of inertia			
Standard motor (U _N = 400 V) 1500 rpm to 0 rpm	10°	9°	9°
Standard motor (U _N = 400 V) 150 rpm to 0 rpm	4°	4°	3°
Asynchronous servomotor (U _N = 330 V) 1500 rpm to 0 rpm	12°	10°	8°
Asynchronous servomotor (U _N = 330 V) 150 rpm to 0 rpm	6°	5°	4°
Braking time 500 ms, external moment of inertia = motor moment of inertia			
Standard motor (U _N = 400 V) 1500 rpm to 0 rpm	9°	9°	9°
Standard motor (U _N = 400 V) 150 rpm to 0 rpm	4°	4°	3°
Asynchronous servomotor (U _N = 330 V) 1500 rpm to 0 rpm	12°	10°	8°
Asynchronous servomotor (U _N = 330 V) 150 rpm to 0 rpm	6°	5°	4°
Values referred to the motor shaft			

Table 3.31 Typical positioning errors referred to the motor shaft in °



10° positioning error, referred to the motor shaft, is equivalent to a positioning error of a traction drive (i=20, drive pinion 60 mm) of +0.15 mm. For more information on the subject of Start/Stop operation refer to section 1.3.3.

$$\Delta_s = \frac{\pi \cdot d \cdot 10^\circ}{360^\circ \cdot i} = [\text{mm}] \quad d = \text{Diameter of drive pinion in mm}$$

3.4.4 Standard drive controller operation

Initial commissioning automatically optimizes the control circuits such that, with drive controller output assigned equal to motor output, the typical power output and torque characteristic shown in Figure 3.50 is produced.

Typical torque characteristic of a standard three-phase AC motor in standard drive controller operation $P_{\text{drive controller}} = P_{\text{motor}}$

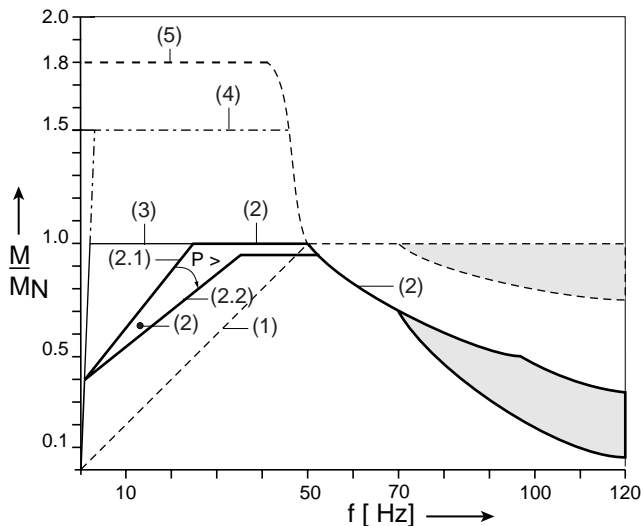


Figure 3.50 Typical torque characteristic of a standard three-phase AC motor

- (1) Delivered power output of a standard three-phase AC motor in standard drive controller operation
- (2) Permissible torque characteristic of an internally cooled standard three-phase AC motor in standard drive controller operation
 - (2.1) Typical characteristic at motor power outputs <4 kW
 - (2.2) Typical characteristic at motor power outputs >15 kW



The typical limit values (2.1) and (2.2) can be increased by approximately 20 % in accordance with thermal class "F".

Precise specifications can be obtained from your motor manufacturer.

- (3) Permissible torque characteristic of an adequately externally cooled standard three-phase AC motors with standard drive controller. It should, however, be noted that at motor power outputs >15 kW a rotor fan is very often used, meaning that the characteristic (3) may need to be reduced.

- (4) Maximum permissible torque of a standard three-phase AC motor to VDE 0530 part 1 (120s).
Maximum torque with drive controllers which permit 150 % overload and have activated motor control method SFC or FOR.
- (5) Maximum torque with drive controllers which permit 180 % overload and have activated motor control method SFC or FOR.



For break-away and acceleration torques dependent on motor control method refer to section 3.4.3.

Special applications

Design (solution)	Application
Motor power lower than power output of drive controllers	Area of application of solution: <ul style="list-style-type: none"> • In applications with acceleration times <500 ms, see section 2.2.1. • In applications requiring high overload torques.
Motor power higher than power output of drive controllers	Area of application of solution: <ul style="list-style-type: none"> • In applications in which internally cooled motors are to be used in continuous operation (S1) over a very broad manipulating range. Note: The motor current consumed in continuous operation must not exceed the rated current of the drive controller.
Six-pole motor on drive controller	Area of application of solution: <ul style="list-style-type: none"> • In applications such as mills, mixers and extruders etc.
Operation of a motor with field weakening	Area of application of solution: <ul style="list-style-type: none"> • In applications with falling load torque such as winders, coilers and lathes etc. For more information see section 3.4.7
Operation of special motors on drive controller	Area of application of solution: <ul style="list-style-type: none"> • See section 2.3
Operation of a motor with 25 % field weakening	Area of application of solution: <ul style="list-style-type: none"> • In applications such as traction and lifting drives. For more information see section 3.4.7
Operation of a motor with 87 Hz characteristic	Area of application of solution: <ul style="list-style-type: none"> • In applications such as traction and lifting drives with expanded manipulating range at constant torque delivery. For more information see section 3.4.8
Several motors on one drive controller	Area of application of solution: <ul style="list-style-type: none"> • In conveying, textile machinery engineering etc. For more information see section 3.4.7

Table 3.32 Special applications

3.4.5 70 Hz characteristic with 25 % field weakening

Traction and lifting drives which operate with 25 % field weakening (70 Hz maximum frequency) offer a wide variety of advantages:

- 40 % more break-away and acceleration torque can be attained without increasing the cost of the drive controller solution.
- Greater economy can be achieved based on saving on an external cooler or reducing the motor power output by one type step.

Beispiel: Drive design with 50 Hz ($F_{\max} = 50$ Hz) and 70 Hz characteristic ($F_{\max} = 70$ Hz)

- Speed manipulating range from 20 to 95 rpm on the gear output shaft
- Output torque on gear output shaft of 150 Nm
- Operation mode S1 (continuous operation), ED = 100 %
- There is no time requirement for the startup and braking response.

1. Drive design with 50 Hz

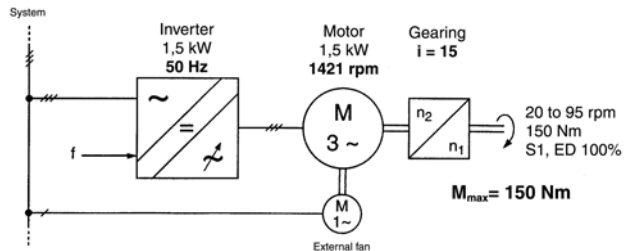


Figure 3.51 50 Hz drive design



The drive design shown above occurs in similar form in almost all fields of engineering. Initial commissioning automatically sets up all three motor control methods.

2. Drive design with 70 Hz

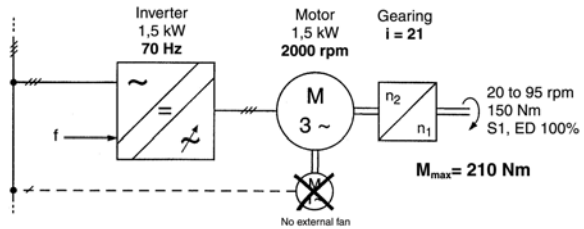


Figure 3.52 70 Hz drive design

In the 70 Hz drive design with 25 % field weakening the maximum speed of the 1.5 kW motor is increased by way of the drive controller from 1421 rpm (50 Hz) to 2000 rpm (70 Hz). The adaptation of the desired output speed on the gearbox is compensated by a higher transmission. However, since a two-stage gearing is required in both cases, the increase in transmission has no influence on cost.



In this case, too, all the motor control methods are set up automatically by initial commissioning. In addition, the max. output frequency needs to be set to 70 Hz in the "Output frequency limitation" software function.

3. Comparison of gear output torques in a drive design with 50 Hz and 70 Hz characteristic

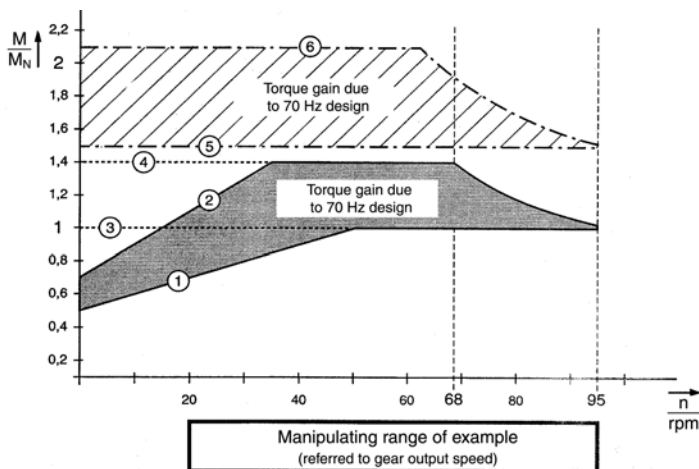


Figure 3.53 Comparison of gear output torques in a drive design for 50 and 70 Hz

Curve 50 Hz	Curve 70 Hz	Notes
1	2	Typical permissible torque characteristic of an internally cooled standard motor (1.5 kW)
3	4	Typical permissible torque characteristic of an externally cooled standard motor (1.5 kW)
5	6	Maximum attainable torque for 60 s of a drive with 1.5 times overload and automatic load compensation

Table 3.33 Comparison of gear output torques in a drive design for 50 and 70 Hz

In summary 40 % higher acceleration torque

In a drive design for 70 Hz the motor is run at a speed higher by the factor 1.4. As a result the maximum power output delivered by the motor is achieved as low as a frequency of 50 Hz and remains constant beyond that level up to 70 Hz. Above 50 Hz the torque falls proportional to the drive controller output frequency. The higher rotation speed of the motor shaft is compensated by s transmission ratio increased by a factor 1.4.

As a result of the speed adjustment the available torque increases by 40 % between 0 and 50 Hz and 0 and 68 rpm. This is equivalent to 40 % more acceleration torque with no increase in cost.

40 % more overload reserve and break-away torque

Proportional to the acceleration torque, a 40 % higher maximum torque is of course also achieved (see characteristics 5 and 6 in Figure 3.50) and thus also a 40 % higher break-away torque.

60 % larger speed manipulating range

The motor speed increased by a factor of 1.4 produces an approx. 60 % larger speed manipulating range on the gear output shaft. Referred to the application set out in Figure 3.51, Figure 3.52 and Figure 3.53 the 70 Hz design even means that no external cooler is needed, and so the space take-up is reduced.

Or a reduction in motor power by one type step

A drive design with field weakening (70 Hz design) can, however, also be designed to usually produce a reduction in motor power by one type step. A reduced motor power saves space and money.

It should, however, be noted that the choice of maximum speed has a major influence on the required acceleration torque and thus on the acceleration time. In practice, at desired acceleration times below 400 ms no reduction in the motor power or drive controller output by one type step is usually attained.

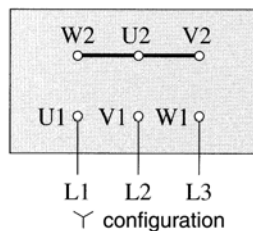
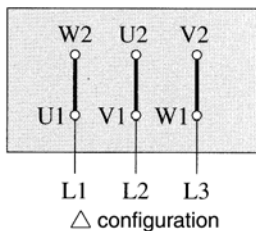
3.4.6 87 Hz characteristic / Expanded manipulating range

The operating range with constant torque of a 400 V / 50 Hz motor in star configuration can be expanded to 87 Hz in delta configuration.

Example: Motor 4 kW/50 Hz in delta configuration

- Rated power 4 kW
- Rated speed 1420 rpm
- Rated voltage 230/400 V
- Delta/Star

1. Reconfigure motor to delta configuration (230 V / delta)



2. Select drive controller power

$$P_{\text{Inverter}} \geq P_{\text{Motor}} \cdot \sqrt{3} =$$

$$= 4 \text{ kW} \cdot 1.73 = 6.9 \text{ kW}$$

Selected drive controllers: CDA34,017
 Rated power 7.5 kW
 Rated voltage 0 ... 400 V
 Max. output frequency 0 ... 100 Hz

3. Drive solution: 87 Hz characteristic

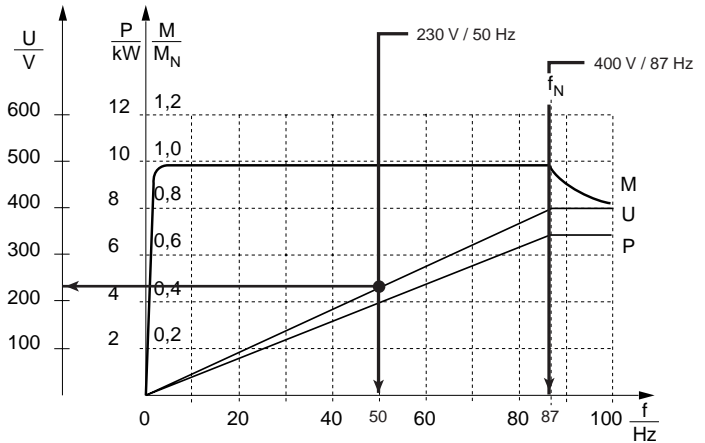


Figure 3.54 Constant torque range to 87 Hz

Design/Application



Design/solution	Applications
Motor with 4 kW / 50 Hz in star configuration on drive controller CDA34,010 (4 kW)	<p>Area of application of solution:</p> <ul style="list-style-type: none"> In applications with constant torque delivery to 50 Hz
Motor with 4 kW / 50 Hz in delta configuration on drive controller CDA34,017 (7.5 kW)	<p>Area of application of solution:</p> <ul style="list-style-type: none"> In applications with constant torque delivery to 87 Hz, e.g. lifting drives <p> Precise data relating to the full-load power (S1, ED 100%) can only be given by the motor manufacturers.</p> <p> During initial commissioning all the parameters for this application are automatically set.</p>

Table 3.34 Applications



The choice of maximum frequency has a major influence on the acceleration power.

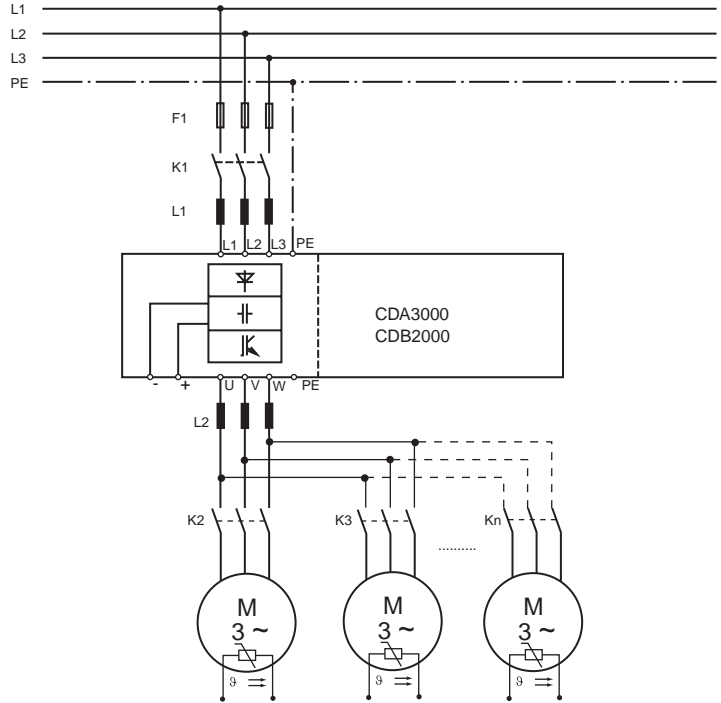
$$P_{\text{MBE}} = \frac{J_{\text{M}} \cdot n^2}{91,2 \cdot t_{\text{BE}}}$$

J_{M}	Motor moment of inertia (rotor) in [kgm ²]
t_{BE}	Acceleration time in [s]
P_{MBE}	Motor acceleration power in [W]

The acceleration power rises with the square of the speed increase (e.g. caused by the choice of max. 87 Hz instead of 50 Hz).

3.4.7 Multi-motor operation on one drive controller

The CDA3000 drive controllers can be run with several motors configured in parallel. Depending on drive task, various project planning conditions must be met.



L1= Line choke
L2= Motor choke

Figure 3.55 Multi-motor operation on one drive controller

Project planning notes for multi-motor operation


Subject	Project planning notes
Current rating of drive controller	The sum of the motor currents must be less than the rated output current of the drive controller $\sum \text{of motor currents, } (I_{M1} + I_{M2} + I_{Mn}) < I_{\text{drive controller}}$
Motor control method	Multi-motor operation is only permitted with the VFC motor control method.
Motor choke	If motors are switched on or off in operation, a motor output choke must always be used. The motor choke limits the du/dt and thus the leakage currents, and protects against switching voltage overload resulting from switching of the motor inductance.
Motor cable length	The total length of the overall motor cable is produced by adding the individual lengths per motor.
Motor protection	In multi-motor operation the parallel-connected motors can only be protected by an in-series configuration of the motor Klixon switches via the inverter. If this is not desired, a thermistor protective relay or PKZM circuit-breaker must be fitted for each motor.
All motors have the same power output	In this application the torque characteristics of all motors remain roughly equal.
The motors have different power outputs	If the motor outputs are very different, problems may occur on startup and at low speeds. This is because of the high stator resistance of small motors and the resultant high voltage drop on the stator coil. In practice: With a power ratio of around 1:4 between the motors, the starting torque of the smallest motor is still approx. 70 % of the nominal torque. If the torque of approx. 70 % is not sufficient, a larger motor must be used. <div style="display: flex; align-items: center;">  <p style="border-top: 1px solid black; border-bottom: 1px solid black; padding: 5px 0;">If all the motors are started together, the small motor will start up later, because the slip frequency is higher.</p> </div>

Table 3.35 *Project planning notes for multi-motor operation*


Subject	Project planning notes
Speed proportionality	Differing motor output speeds can only be attained by using motors with differing rated speeds, e.g. 1440 rpm and 2880 rpm. The speed ratio of approx. 1:2 is maintained during the speed change. The accuracy depends on the slip and thus on the load.
Shut-off and activation of individual motors	<p>Shut-off of motors, see section 3.2.13</p> <p>When connecting motors, ensure that the connection current is not higher than the drive controller peak current. It is advantageous if the drive controller load is >40 %.</p> <p>This 40 % base load backs up the output voltage of the drive controller at the moment of connection of the motor.</p> <div style="display: flex; align-items: center; margin-top: 10px;">  <p>During connection the motor must not be run in the field weakening range, since the connected motor would otherwise have to run at reduced runup torque.</p> </div>

Table 3.35 *Project planning notes for multi-motor operation*

3.4.8 Encoder selection for FOR mode with CDA3000

The inverter modules as standard permit operation of a three-phase asynchronous machine with Field Oriented Regulation (FOR), providing the inverter drive system featuring three-phase asynchronous motors with a similar quality of control and load capacity as servo drive systems featuring resolver feedback or DC drives.

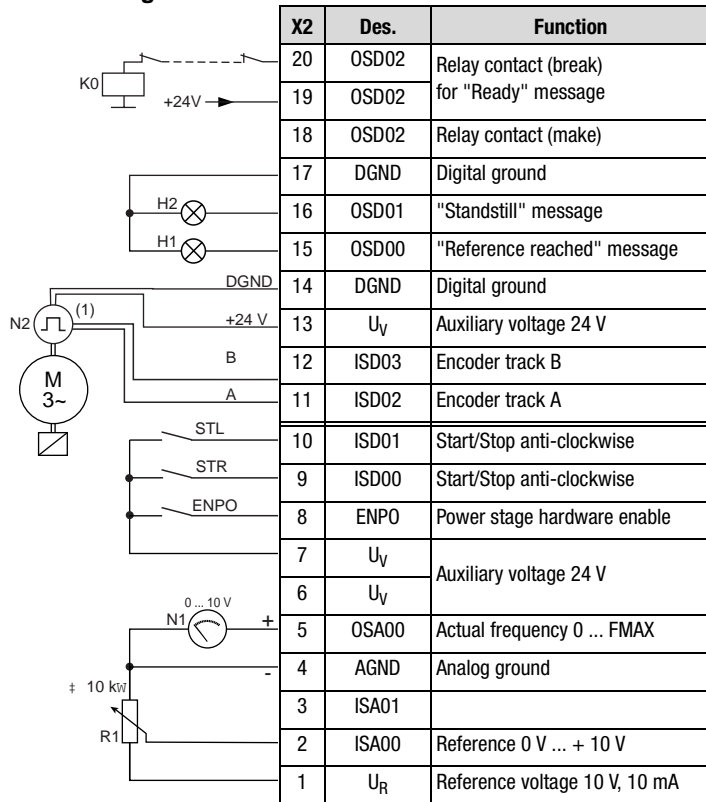
The encoder connection for the FOR control mode is made via the digital inputs ISD02 (X2/11) and ISD03 (X2/12) of the CDA3000 inverter module. The pulse signal delivered by the encoder is additionally quadrupled by the inverter module, providing a high-grade speed control with outstanding smooth running properties.

Suitable encoders must deliver a square signal with PLC level, as IEC1131 compatible inputs ($L = <5\text{ V}$, $H = >18\text{ V}$) are used to evaluate the encoder signals. Encoder systems with this voltage range (10 - 30 V) are termed HTL encoders. The HTL encoders have a push-pull power stage, with A and B tracks at a 90° phase offset. The rotary encoders mostly additionally deliver two inverted signals \bar{A} and \bar{B} . The additional \bar{A} and \bar{B} signals are not needed for CDA3000 inverter modules.



Encoders without inverted output signals can also be evaluated. Encoders of this kind (encoder bearings, magnetic ring encoders) are in widespread use in simple applications. When using these encoders, the special operating conditions, such as short-circuit proofing, magnetic interference etc., must be considered. For details of these special features refer to the encoder manufacturers' data sheets. Use of such encoders requires precise analysis, and can only be approved on a project-specific basis.

Connection example from operation manual "Terminal assignment 4"



- (1) Only encoder type HTL (24 V supply) usable. The encoder is evaluated only in control mode FOR. For notes on the encoder see Figure 3.57.

Figure 3.56 Control terminal assignment, rotational drive with encoder evaluation

Encoder

A HTL encoder (24 V supply) can be connected to terminals X2/11 and 12. Permissible pulse counts are in the range 32 to 16384 pulses per rev. in the stepwidth for the pulses of 2^n with $n = 5$ to 14.

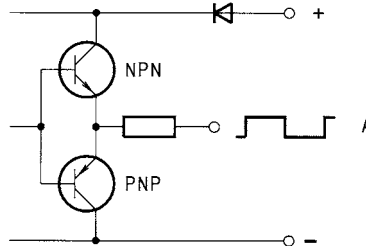


Figure 3.57 Block diagram, HTL output circuit

Specification of digital inputs ISD02 and ISD03

- $f_{limit} = 150 \text{ kHz}$
- IEC1131-compatible (L = < 5 V, H = > 18 V)

The following project planning notes must also be observed:

- Cable length max. 30 metres, with encoder specified in Table 3.38.
- Screened twisted-pair cable with approx. 60 nF/km.
- Observe max. current sampling for encoder supply from inverter module of $\leq 80 \text{ mA}$.

Maximum number of lines of encoder

$$SZ_{max} = \frac{9 \cdot 10^6}{n_{max}}$$

SZ_{max} Maximum number of lines of encoder in pulses per rev.

n_{max} Maximum speed of motor in rpm

Maximum motor speed [rpm]	Encoder lines per revolution [pulses per rev.]	Maximum frequency [Hz]	
		2-pole ASM	4-pole ASM
8788	1024	146	292
4393	2048	73	146
2196	4096	36	73

Table 3.36 Maximum speed when using encoders with differing lines per revolution

Example for $n_{\max} = 6000$

Calculated: $SZ_{\max} = \frac{9 \cdot 10^6}{6000} = 1500$ pulses per rev.

Selected: An encoder with a line count of < 1500 pulses per rev.
The optimum encoder has 1024 pulses per rev.

Minimum motor speed

Formula for calculating the minimum motor speed depending on the encoder lines per revolution so that one pulse of the encoder can be evaluated each scan cycle of the inverter module.

$$n_{\min} = \frac{3000}{SZ} \cdot \frac{1}{\min}$$

SZ Encoder lines in pulses per rev.
 n_{\min} Minimum speed of motor in rpm

Minimum speeds for speed control

Encoder lines per revolution [pulses per rev.]	Minimum motor speed [rpm]	Minimum frequency [Hz]	
		2-pole ASM	4-pole ASM
32	94	1.6	3.3
64	48	0.8	1.6
128	24	0.4	0.8
256	12	0.2	0.4
512	6	0.1	0.2
1024	3	0.05	0.1
2048	1.5	0.03	0.05
4096	0.8	0.02	0.04
8192	0.4	0.01	0.03
16384	0.2	0.01	0.01

Table 3.37 Minimum speeds when using encoders with differing lines per revolution

Recommended encoder types

During approval testing, not only was the encoder input (ISD02/3) qualified in accordance with EN 61000-4-2 to 5, the interaction between encoders from different manufacturers and the inverter module as well as the Field Oriented Regulation were tested. The tested encoders are listed in Table 3.38.

Type	Stegmann	Stegmann	Thalhein	IVO
Properties	DG60 ELB	HG660 AKR	ITD40A4Y2 1024HBI	GI 356.1604A29
Design	Built-on encoder	Hollow-shaft encoder	Hollow-shaft encoder	Built-on encoder Syn.Fl. 58 mm
Tested lines per rev.	1024	1024	2048	1024
Max. input frequency at ISD02/03	150 kHz	150 kHz	150 kHz	150 kHz
Tested cable length	30 m	30 m	30 m	30 m
EN61000-4-4 Burst	4 kV	4 kV	4 kV	4 kV
Cable type	Screened cable approx. 60 nF/km	Screened cable approx. 60 nF/km	Screened cable approx. 60 nF/km	Screened cable approx. 60 nF/km

Table 3.38 Tested encoders on the CDA3000 inverter module

Type	Stegmann	Stegmann	Thalheim	IVO
Properties	DG60 ELB	HG660 AKR	ITD40A4Y2 1024HBI	GI 356.1604A29
Current supply	< 60 mA	< 60 mA	< 60 mA	< 60 mA
Voltage supply	10 - 30 V DC	10 - 30 V DC	10 - 30 V DC	10 - 30 V DC
Polarity reversal protection	Yes	Yes	Yes	Yes

Table 3.38 Tested encoders on the CDA3000 inverter module



Note on mechanical design:

- No shock impacting on encoder housings and shafts, e.g. from hammer blows etc.
- Uniform axial loading (use balancing elements)
- Provide IP protection or explosion-proofing as appropriate
- Select encoder cable according to mechanical requirements (e.g. fixed layout, festoon compatibility, ambient conditions etc.)

Hollow-shaft designs have proved successful in retrofitting of built-on encoders. In this, the encoder is fitted directly onto the second shaft end of the motor and fixed in place over the motor housing. This avoids complex axial centring of the encoder and motor.

3.4.9 Programming examples for applications with CDA3000-PLC

The PLC firmware comprises the basic software - see CDA3000 user documentation - and a PLC application platform based on it.

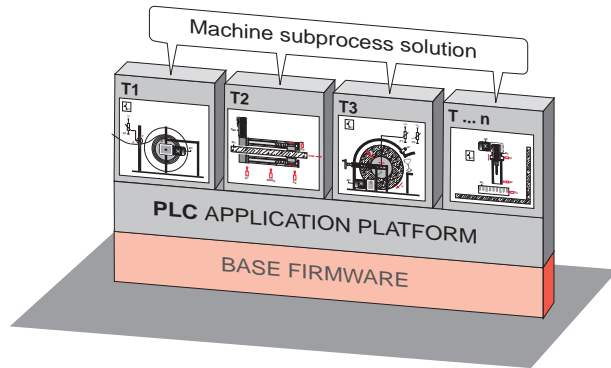


Figure 3.58 PLC firmware

The area of application of the PLC application platform for writing automation programs permits a wide variety of new solutions, also supported by a graduated series of operator panels.

The machine subprocesses for which solutions have already been delivered are:

I/O oriented processes

Movement solutions in which the subprocess sequences are essentially dictated by I/O signals from the processing processes. Of note in this are:

- Feed unit for drilling or sinking
- Belt and trolley drives
- Door and gate drives
- Pump installations with float switch
- Pallet lifting and rotating platforms

Timed processes

Movement solutions in which subprocess sequences are essentially dictated by time. Typical applications are:

- Stirrers and mixers e.g. for paints
- A wide range of centrifuges and dispersers
- Milling and reducing machines

Closed-loop processes

Movement solutions in which process variables such as torque, tensile force, pressure, temperature or position need to be kept constant in the processing process. This involves subprocesses such as:

- Wobbler or dancer control for coiling/spooling
- Anti-blocking control for reducing machines
- Simple positioning tasks for traction, rotary, door and gate drives
- Classic pressure, temperature and flow control



The following programming exercises are intended for the CDA3000-PLC inverter series. The task and the suggested solutions have been tested in terms of safety.

Lust Antriebstechnik GmbH can consequently accept no responsibility or liability arising from use of the programming exercises.

Timed box belt drive

When the box cuts the light beam of the light barrier L1 the conveyor belt FB is started. The maximum conveying speed is preset by potentiometer P1.

The cycle time of the conveyor belt FB is preset by potentiometer P2. When the time preset by potentiometer P2 has elapsed the inverter M1, FU1 is shut off and the belt runs down to a stop.

Diagram

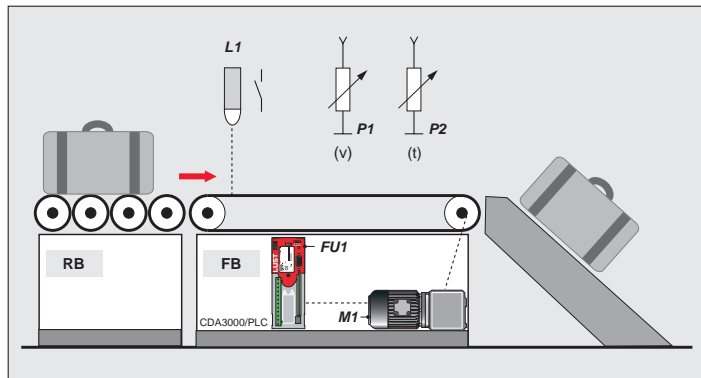


Figure 3.59 Timed box belt drive

Sequence program

```

; Sequence program for CDA-PLC, e.g. Box belt drive

;Initialization
;Reference input via analog input ISA0 with corresponding scaling
in device parameters

%TEXT(box belt)
DEF H000= Max. cycle time
DEF H001= Auxiliary variable
DEF H002= Analog input
END

%P00
N010 SET H000=20000;      Maximum cycle time in ms
N020 SET H001=H000;      Auxiliary variable
N021 SET H001:1023;      Resolution of analog input 10-bit

N050 JMP (IS00=0) N050;  Wait for release signal from
;                          light barrier
N060 SET ENCTRL=1;       Start control

;Read timer value from analog input ISA1
N070 SET H002=ISA1;      Analog value in H002
N075 SET H002*H001;      Calculate-in resolution of analog input

;Initialize timer
N080 SET Z00=H002
N085 JMP (Z00!=0) N085;  Wait for timer to elapse

;Stop control
N090 SET ENCTRL = 0

N100 JMP N020;   Go back
END

```



Other typical application examples are stirrers and mixers for paint and other media as well as centrifuges, mills and reducing machines.

Drill feed unit

The drilling assembly consists of a drilling spindle, feed unit and conveyor. The following deals only with the "drilling" subprocess, meaning the spindle and feed drive.

Basic setting

The drill unit is at its basic setting when

- the feed unit is at the top position (S1 damped),
- the drilling assembly is free (S3 not damped) and
- spindle M1, FU1 is switched off.

Function sequence

When the workpiece W1 is in the drilling assembly (S3 damped) and the Start button b1 is pressed, the drill unit is released to start machining.

The drill spindle M1, FU1 runs up to machining speed. Once the drill spindle M1, FU1 has reached machining speed, the drill unit is lowered via the feed drive M2, FU2.

When the bottom sensor (S2) is approached the reversal point is reached. The feed unit M2, FU2 reverses, causing the drill spindle to return to its basic setting.

When the top sensor (S1) is approached the feed drive M2, FU2 and the drill spindle M1, FU1 stop automatically. The workpiece is taken out by the conveyor and the process can start again from the beginning.

The rotation speed of the spindle and rate of feed are set on the operator panel OP.

Diagram

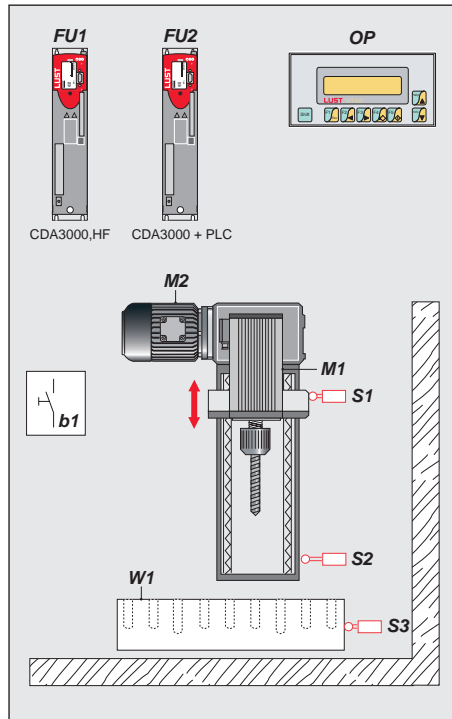


Figure 3.60 Drill feed unit

Sequence program

```

;Specimen program - Feed unit

;Inputs:
;M001=Start feed
;IS01=Pre-stop NC contact
;IS02=Top limit switch NC contact
;IS03=Bottom limit switch NO contact

%TEXT (feed)
DEF H000 = Reference_0
DEF H001 = Timer_1
DEF M002 = Initialized
DEF H002 = Input frequency
DEF H003 = Slow jog frequency
DEF H004 = Waiting time
DEF H010 = Quick jog_positive
DEF H011 = Quick jog_negative
DEF H012 = Slow jog_positive
DEF H013 = Slow jog_negative
DEF M001 = Start movement
END
    
```

```

; sequence program for CDA-PLC
%P00
N005 SET H000=0;           reference 0
N010 SET H001=1000;       value for timer 1
N015 JMP (M002=1) N031;   skip initialization
N020 SET H002=70;        reference feed Hz
N030 SET H003=20;        slow jog
N031 SET H004=200;       waiting time operating point
N032 SET M002=1

N040 SET H010=H002;       operating variable quick jog positive
N041 SET H011=H002;       operating variable quick jog negative
N042 INV H011

N050 SET H012=H003;       operating variable slow jog positive
N051 SET H013=H003
N052 INV H013

N060 JMP (M001=1) N100;   start feed
N065 JMP (IS02=0) N040;   axis at top limit switch
N070 SET REFFRQ=H010;     move axis to top limit switch
N075 JMP (IS02=1) N075;   wait for limit switch to be reached
N080 SET REFFRQ=H000;     stop axis
N081 SET OS00=1;         axis at top position
N082 SET OS01=0
N085 JMP N040;           close loop

N100 SET REFFRQ=H011;     start feed - quick jog
N105 SET OS00=0;         axis moves
N109 JMP (M001=0) N040
N110 JMP (IS01=1) N109;   monitor pre-stop contact
N120 SET REFFRQ=H013;     switch slow jog
N129 JMP (M001=0) N040
N130 JMP (IS03=0) N129;   wait for bottom limit switch
N140 SET REFFRQ=H000;     stop axis

N150 JMP (M001=0) N040
N151 SET REFFRQ=H012;     return to pre-stop
N152 JMP (M001=0) N040
N153 JMP (IS01=0) N152
N154 WAIT H004
N155 JMP N120;           feed

N190 JMP N040
END                       ;program end

```



Other typical application examples are belt and trolley drives, door and gate drives, pallet lifting and rotating platforms and pump installations with float switch for example.

Shredder with overload detector

Reducing machines of different kinds (crushers, mincers, shredders etc.) are deployed in various applications, such as in the food industry and the construction industry, as well as in the office environment. A frequent problem during reduction is blockage of the drive.

This example shows a shredder with an overload detector and automatic release (roller reverse) in the event of a blockage. The user can set parameters to control the functioning of the overload detector. For this, the user enters response times in case of overload, a minimum time for overload and the number of attempted release movements by way of the recipe management system.

Function description

When the drive FU1.M1 is started by pressing the button b1 the rollers of the crusher rotate at a programmable fixed frequency in the forward direction A. During operation the PLC takes over from FU1 the monitoring of the motor current I within a programmable threshold. If the threshold is exceeded, i.e. in case of overload or blockage of the roller, the drive is stopped, provided the preset overload time has elapsed. After a likewise programmable time a reversal of the roller in direction B is triggered (release). The duration of the reversal can likewise be controlled by PLC timer. After the reversal normal operation in direction A is resumed. If an overload occurs repeatedly (number of times programmable in PLC) within a programmable time, the drive is stopped.

All timers and threshold values are set on the operator panel OP by way of the built-in recipe management system.

Diagram

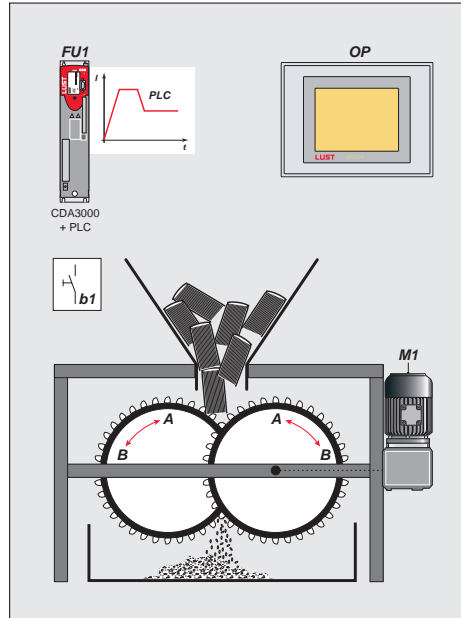


Figure 3.61 Shredder with overload detector

Sequence program

```

; sequence program for CDA shredder

; inputs
; IS00 - start control
; IS01 - start sequence program

; outputs
; OS00 - overload warning
; OS01 - reference reached
; OS02 - S-RDY

%TEXT(shredder)
DEF H001 = timer_overload
DEF H002 = pause time_overload
DEF H003 = reversing time
DEF H004 = timer_repeat
DEF H005 = counter_reverse
DEF H006 = max_repeats
DEF H010 = reference_operation
DEF H011 = reference_reverse
DEF F000 = apparent current
DEF F001 = threshold
END

%P00
;init
    
```



```

N005 SET H001 = 500;           response time on overload (ms),
Z000
N010 SET H002 = 500;           pause time on overload (ms)
N015 SET H003 = 3000;         reversing time (ms)
N020 SET H004 = 20000;        timer repeats reverse
N025 SET H005 = 0;           counter reverse attempts
N030 SET H006 = 3;           max. value counter
N035 SET H010 = 50;          reference forward (Hz)
N040 SET H011 = -20;         reference reverse (Hz)

N045 SET F000 = 0;           apparent current
N050 SET F001 = 1;           threshold overload

;main program
N055 SET H005 = 0
N060 SET Z001 = H004;         timer repeats reverse
N065 SET REFFRQ = H010;      forward

N070 SET F000 = PARA[408];    get apparent current
N075 JMP (Z001 = 0) N055;     timer repeats reset
N080 JMP (F000 < F001) N070

N085 SET Z000 = H001;         timer response time overload

N090 SET F000 = PARA[408];    get apparent current

N095 JMP (F000 < F001) N070;  overload eliminated?
N100 JMP (Z000 != 0) N090;   timer elapsed?

N105 SET REFFRQ = H000;      stop drive
N110 WAIT H002 ;             wait pause time

N115 JMP (H005 = H006) N145;  reversed too often

N120 SET REFFRQ = H011;      reference reverse
N125 SET H005 + 1;           reverse counter
N130 WAIT H003 ;             reversing time
N135 WAIT H002 ;             pause time

N140 JMP N065 ;              go back to forward

N145 NOP
END ;                          Program end

```

Another solution to this application is shown by the following program. The sequence is slightly different to the function description set out above.

```

; plc program for shredder
parameter
; 270-FFIX1 = reference forward
; 271-FFIX2 = reference reverse
; Line 55 special function warning current
; inputs
; IS00 - Start forward
; IS01 - Start reverse
; IS02 - Stop
; IS03 - fault reset
; outputs
; OS00 - c_rdy
; OS01 - reference reached
; OS02 - warning current limit
%TEXT(shredder)
DEF H000 = value timer reverse
DEF H001 = value timer repeat
DEF H002 = max repeat
DEF H003 = repeat
DEF M000 = STA_WIS

```

```

DEF Z000 = timer reverse
DEF Z001 = timer repeat
DEF F000 = reference forward
DEF F001 = reference reverse
DEF F003 = reference 0
END

%P00
;Init
N005 SET H000 = 5000;    timer reverse
N006 SET H001 = 600000; timer repeat
N007 SET H002 = 3;      max count repeat
N010 SET F000 = PARA[270];reference forward
N011 SET F001= PARA[271];reference reverse
N012 SET F003=0

;main
N030 SET REFFRQ=F003
N035 SET OS02=0

N040 JMP (IS00=1) N050; start forward
N041 JMP (IS01=1) N200; start reverse
N043 JMP N040

N050 SET H003=1
N051 SET Z001 = H001;    timer repeats reverse
N052 SET ENCTRL=1;     enable control
N053 SET REFFRQ = F000; forward
N054 WAIT 2000;        waiting for acceleration

N055 SET M000 = STA_WIS; warning current?
N056 JMP (Z001=0) N050; timer repeats reset
N057 JMP (IS02=1) N030
N060 JMP (M000=0) N055; no warning

N070 SET Z000=H000;    timer reverse
N071 SET H003+1;      count reverse
N075 JMP (H003>H002) N150;max count reverse
N080 SET REFFRQ = F001; reference reverse
N085 JMP (Z000=0) N053; timer reverse
N090 JMP (IS02=1) N030; stop required
N095 SET M000 = 0
N100 JMP N085

N150 SET REFFRQ=F003; stop
N155 SET OS02=1
N160 JMP (IS03=0)N160; Waiting for reset
N165 SET OS02=0
N170 JMP N030

N200 SET ENCTRL=1;    enable control
N201 SET REFFRQ = F001; start reverse
N210 JMP (IS02=1) N030; stop required
N220 JMP N210

END                                ;program end

```



Other typical applications are anti-blocking controls for mixers, mills and reducing machines.

Wire uncoiling drive

The uncoiling drive described here supplies a dry or wet wire drawing machine with material. The solution to the autonomous subprocess involves integration of the drive solution into the automatic operation mode and the setup mode.

Function description

The uncoil speed is regulated via the drive unit FU1.M1 and the implemented process controller and a feedback via dancer T. A setup mode is implemented to help the user mount a fresh coil of wire on the spindle D. The setup mode is activated only at standstill by a switch b1 and via control input IS02 on the frequency inverter FU1.

In setup mode the drive FU1.M1 runs at a fixed speed and monitors the motor current. The motor current remains below a programmable limit until the dog on the drive shaft picks up the wire coil. Then the drive FU1.M1 must stop immediately so the operator can fix the coil on the drive shaft.

Monitoring of the dancer position P2 in automatic mode detects the point from which wire is drawn off and automatically activates the drive control FU1.M1.

Diagram

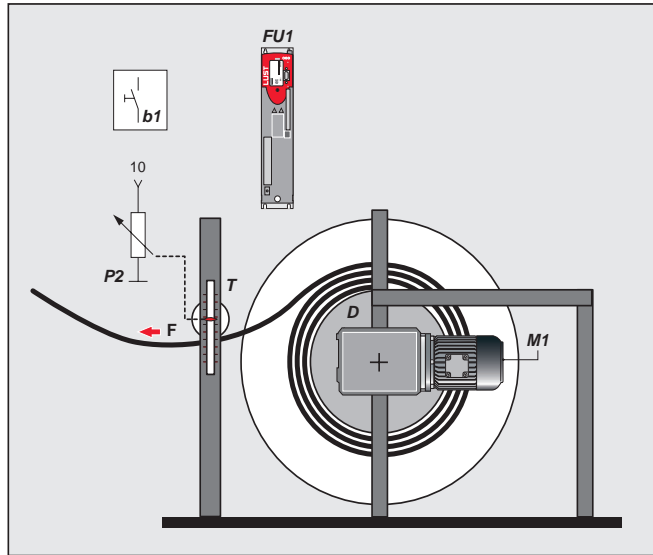


Figure 3.62 Wire uncoiling drive

Sequence program

```

; sequence program for CDA-PLC, wire uncoiling
; (coiler with dancer control)
; dancer control via process controller in firmware

%TEXT(coiler)
DEF H001=Threshold
DEF H002=Waiting time
DEF H000=Analog value
DEF M001=Warning_current
END

%P00
;initialization
N010 SET H001=10;           threshold dancer
N011 SET H002=500;         waiting time startup in ms

;main program
N020 JMP (IS02=1) N100;    setup mode with fixed frequency
N030 SET H000=ISA0;        monitor dancer excursion
N035 JMP (H000<H001) N020;start on dancer excursion

;control process
N050 SET ENCTRL=1;        enable control
N060 SET H000=ISA0;        monitor dancer excursion
N065 JMP (H000>H001) N060;stop at dancer end position
N070 SET ENCTRL=0;        control off
N080 JMP N020

;setup mode

```

```
N100 SET ENCTRL=1;          enable control
N110 WAIT H002;            waiting time startup
N115 SET M001=STA_WIS;     warning threshold apparent current
                           exceeded?
N120 JMP (IS02=0) N020;    setup mode cancelled
N125 JMP (M001=0) N115;    load surge monitored?
N130 SET ENCTRL=0;        control off
N140 JMP N020
```

END



Other typical application examples are wobblers and dancer controls for coiling/spooling drives.

Diameter-dependent velocity control

This specimen PLC program controls the main drive of a polishing machine. The circumferential velocity must be kept constant taking into account the wear of the polishing wheel.

Function description

The drive FU1.M1 is switched on by the switch b1. The reference value for the circumferential velocity ω is transmitted via the potentiometer P2 to the sequence program.

The program works directly in user units, i.e. the circumferential velocity has the unit [m/s] and the wheel circumference the unit [m]. The scalings necessary for this are defined in the sequence program. In the specimen program this is scaled to the customer-specific manipulating range of 10 m/s-34.5 m/s.

If the polishing wheel is worn, a handwheel can be turned to adjust it to maintain the optimum distance to the working surface at all time. This mechanical adjuster at the same time delivers a 0-10 V analog signal for the adjustment range via the potentiometer P1. The adjustment position is directly proportional to the diameter of the polishing wheel x . If the diameter then changes, the new reference frequency of the main drive M1 is calculated from the analog information at the specified constant circumferential velocity. In this example the diameter of the wheel is between 0.55 m and 0.96 m (\Rightarrow circumference 1.73 m - 3.01 m).

The initiator S1 monitors the distance between the polishing wheel and the protective cover. If the distance is too small starting of the main drive is prevented, or if it is running, the drive is stopped.

Diagram

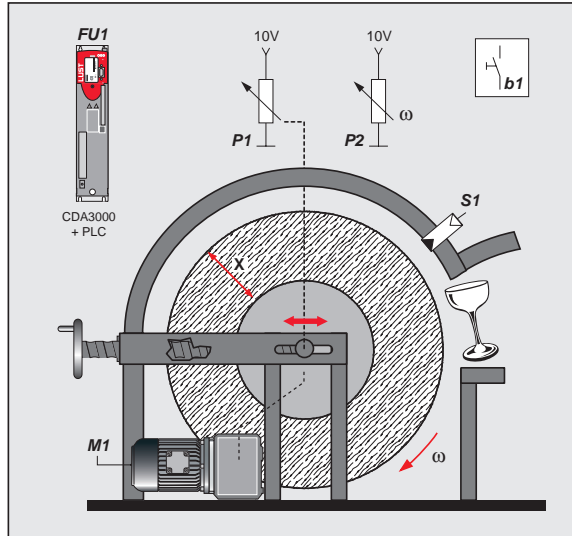


Figure 3.63 Diameter-dependent velocity control

Sequence program

```

; sequence program for CDA-PLC polishing machine
; info:
; velocity reference via ISA0, with following customer-specific
; settings
;   0V = 10m/s
;   10V = 34.5m/s   -> Delta = 24.5m/s   -> Resolution 2.45m/s/V
;
; circumference reference via potentiometer at ISA1, with
; following customer-spec. settings
;   0V -> 0.96m => 3.01m max. circumference
;   10V -> 0.55m => 1.73m min. circumference -> Delta = 1.28m ->
;   Resolution 0.128m/V
;
;
%TEXT(grinding wheel)
DEF F000=Analog value 0
DEF F003=Analog value 1
DEF F002=Reference_m_per_s
DEF F005=Circumference_m
DEF F007=Reference_U_per_min
DEF F009=Reference_in_Hz
END

;F002=ISA0 Reference in m/s, auxiliary variables (F000-001)
;F005=ISA1 Actual in m, auxiliary variables (F003-004)

%P00
;reference and actual definition

```

```

N010 SET F000=PARAM[416]; get analog value 0
N015 SET F000*2.45;      scaling in m/s
N020 SET F001=F000
N021 SET F001+10;      reference in m/s +offset of 10m/s
N022 SET F002=F001;      save reference

N030 SET F003=PARAM[417]; get analog value 1
N035 SET F003*0.128;    scaling in m
N040 SET F004=3.01;     max. circumference = 3.01m
N041 SET F004-F003;     actual circumference in m
N042 SET F005=F004;     current circumference in m

;calculation reference in m/s
N050 SET F006=F002
N055 SET F006*60;       conversion m/min
N065 SET F006:F005;     conversion into revolutions per min on
; grinding wheel
N070 SET F007=F006;     save reference in F007

;calculation speed -> frequency
N100 SET F008=F007;     get speed
N110 SET F008*2;        include gear reduction ratio 1:2
;
N115 SET F008:20;       calculate rotating field frequency:
; f=n*pp/60, pp=3
N120 SET F009=F008;     save reference in Hz

N150 SET REFFRQ=F009;   set frequency reference

N250 JMP N010
END                      ;program end

```



Other typical applications are coiling/spooling drives with diameter control.

3.4.10 Low motor losses based on CDA3000 with high-frequency PWM

Why is the modulation of the PWM signal so key? – The PWM pattern of the output voltage simulates the sinusoidal characteristic of the motor current on an inductor. The more the sine shape is corrupted by poor PWM patterns, the higher is the harmonic content. It is a fact that the fundamental converts effective power. The harmonics result in additional remagnetizing losses and cause unnecessary heat loss. This is thermally critically especially for the compact high-speed spindles.

With the microcontroller technology available today a variety of PWM methods can already be created. The c-line DRIVES CDA3000, HF inverter family uses the high-performance Siemens SAB80C167 microcontroller. Despite this, the C167 microcontroller's resources alone are not adequate to meet the demands of HF ... PWM.

By skilled coupling of two modulation units (C167 and CPLD) ¹⁾ calculation of the voltage space vector was increased to twice the power stage clock frequency (max. 32 kHz) and precise calculation of both PWM edges was enabled.

The result is positively reflected in the low harmonic content of the motor current. The motor heat-up is significantly reduced. In the diagram shown (siehe Figure 3.64), for clearer illustration the harmonics were measured with reference to the fundamental of the motor current. The influences of the Fourier analysis on the current by the filter and motor in themselves are of minor importance in this practice-oriented measurement.

1) (CMOS programmable logic device)

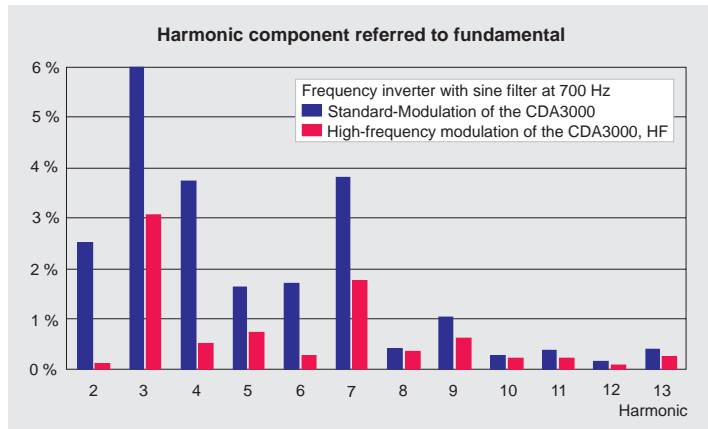


Figure 3.64 Reduction in current harmonics based on CDA3000 with HF modulation

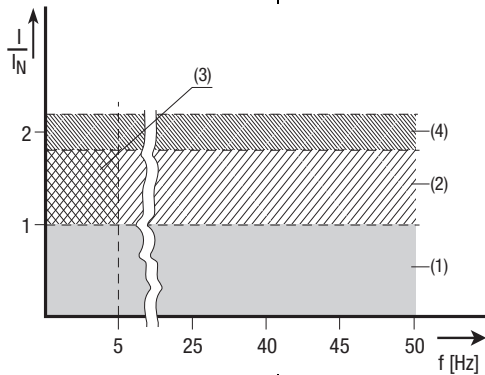
The area of application of high-frequency drives such as high-speed spindles extends across a broad spectrum: As main drives in the woodworking industry; grinding and milling spindle drives in metalworking; centrifuge drives in medical technology; vacuum pump drives; cooling fan drives in laser technology; and, not least, as spooling drives in the textile industry. The applications are diverse, but the question remains: What impact does the temperature reduction have in practice? What advantages result, for example, for the company operating the machine tool? This does not need lengthy consideration, because the main effect of a temperature reduction in this segment is seen in the increased machine productivity. The following sets out a number of key points for machine tool drives which apply similarly to the above-mentioned drives:

- Higher machining accuracy based on little extension of the motor shaft
- Smoother running and so quieter operation results in better micrographs
- Longer life of the precision bearings and lubricating oils extends service intervals
- Reduced stress on the winding insulation enhances availability

3.5 c-line positioning drive CDE/CDB3000

3.5.1 Current capacity of positioning drives CDE/CDB3000

The maximum permissible positioning drive output current and the peak current are dependent on the mains voltage, the motor cable length, the power stage switching frequency and the ambient temperature. If the conditions change, the maximum permissible current capacity of the positioning drives also changes - refer to the following graphs and tables.



*Intermittent $I_N > I_{eff}$

$$I_{eff} = \sqrt{\frac{1}{T} \cdot \sum_{i=1}^n I_i^2 \cdot t_i}$$

- (1) **Continuous operation**
- (2) **Intermittent* > 5 Hz Rotating field frequency**
 Positioning drive 0.7 to 15 kW (CDE/CDB)
 $I/I_N = 1.8$ for 30 s at 4/8/16 kHz
 Positioning drive 45 at 170 A (CDE)
 $I/I_N = 2.0$ for 3 s at 4/8 kHz
 Positioning drive 22 to 90 kW (CDB)
 $I/I_N = 1.5$ for 30 s at 4/8 kHz
- (3) **Intermittent* 0 to 5 Hz Rotating field frequency**
 Positioning drive 0.7 to 15 kW (CDE/CDB)
 $I/I_N = 1.8$ for 30 s at 4 kHz
 $I/I_N = 1.25 - 1.8$ for 30 s at 8 kHz
 Positioning drive 45 to 170 A (CDE)
 $I/I_N = 2.0$ for 3 s at 4/8 kHz
 Positioning drive 22 to 90 kW (CDB)
 $I/I_N = 1.5$ for 30 s at 4 kHz
 $I/I_N = 1.0-1.15$ for 30 s at 8 kHz
- (4) **Pulse mode**
 Positioning drive 0.7 to 15 kW
 $I/I_N = \text{approx. } 2.2$ at 4/8/16 kHz
 Positioning drive 45 to 170 A (CDE)
 $I/I_N = \text{approx. } 2.2$ at 4/8 kHz
 Positioning drive 22 to 90 kW (CDB)
 $I/I_N = \text{approx. } 1.8$ at 4/8 kHz

Positioning drives for 230 V systems

Positioning module	Rec. 4-pole standard motor [kW]	Switching frequency of power stage [kHz]	Rated current [A]	Peak current for intermittent mode 0 to 5 Hz [A]	Peak current for intermittent mode > 5 Hz [A]
CDE/CDB32,003.Cx.x	0.37	4 8 12 16	2.4 2.4 2.1 1.8	4.3 4.3 3.75 3.2	4.3 4.3 3.75 3.2
CDE/CDB 32,004.Cx.x ¹⁾	0.75	4 8 12 16	4 4 3.5 3	7.2 7.2 5.7 5.0	7.2 7.2 6.3 5.4
CDB32,008.Cx.x ¹⁾ CDE/CDB 32,008.Wx.x	1.5	4 8 12 16	7.1 7.1 6.3 5.5	12.8 12.8 10 8	12.8 12.8 11.35 9.9
Peak current for 30 s with positioning drive 0.375 to 1.5 kW / 2.4 to 7.1 A Cooling air temperature 45 °C (40 °C CDB32,008.Cx.x) at power stage switching frequency 4 kHz 40 °C at power stage switching frequency 8, 16 kHz 1) With heat sink HS3... or additional cooling surface				Mains voltage 1 x 230 V -20 % +15 % Motor cable length 10 m Mounting height 1000 m above MSL End-to-end mounting	

Table 3.39 Positioning drives for 230 V systems

Positioning drives for 400/460 V systems

Positioning module	Rec. 4-pole standard motor [kW]	Switching frequency of power stage [kHz]	Rated current I_N [A] at 400 V	Rated current I_N [A] at 460 V	Peak current for intermittent mode 0 to 5 Hz [A]	Peak current for intermittent mode > 5 Hz [A]
CDE/CDB 34,003.Cx.x	0.75	4	2.2	2.2	4	4
		8	2.2	2.2	4	4
		12	1.6	1.6	2.9	2.9
		16	1.0	1.0	1.8	1.8
CDE/CDB 34,005.Wx.x	1.5	4	4.1	4.1	7.4	7.4
		8	4.1	3.6	7.4	7.4
		12	3.2	-	5.7	5.7
		16	2.4	-	4.3	4.3
CDE/CDB 34,006.Wx.x	2.2	4	5.7	5.7	10.3	10.3
		8	5.7	5.7	10.3(CDE)/ 7.8(CDB)	10.3
		12	4.15	-	7.5(CDE)/ 6.4(CDB)	7.5
		16	2.6	-	4.7	4.7
CDE/CDB 34,008.Wx.x	3.0	4	7.8	7.8	14	14
		8	7.8	7.8	14	14
		12	6.4	-	11	11
		16	5	-	7.8	9
CDE/CDB 34,005.Wx.x	4.0	4	10	10	18	18
		8	10	8.8	18	18
		12	8.1	-	13	14.5
		16	6.2	-	7.8	11
CDE/CDB 34,014.Wx.x	5.5	4	14	14	25	25
		8	14	12.2	25	25
		12	10.3	-	18	18
		16	6.6	-	12	12
CDE/CDB 34,006.Wx.x	7.5	4	17	17	31	31
		8	17	13.5	31	31
		12	12.5	-	23	23
		16	8	-	14	14
CDE/CDB 34,024.Wx.x	11	4	24	24	43	43
		8	24	24	43	43
		12	19.5	-	35	35
		16	15	-	27	27

Cooling air temperature 45 °C (40 °C CDB34,003.Cx.x)
 at power stage switching frequency 4 kHz
 40 °C at power stage switching frequency 8, 16 kHz

Motor cable length 10 m
 Mounting height 1000 m above MSL
 End-to-end mounting

¹⁾ Devices available as from 3rd quarter 2006.

²⁾ Not available at time of going to press.

Table 3.40 Positioning drives for 400/460 V systems

Positioning module	Rec. 4-pole standard motor [kW]	Switching frequency of power stage [kHz]	Rated current I_N [A] at 400 V	Rated current I_N [A] at 460 V	Peak current for intermittent mode 0 to 5 Hz [A]	Peak current for intermittent mode > 5 Hz [A]
CDE/CDB 34,008.Wx.x	15	4	32	32	58	58
		8	32	28	58	58
		12	26	-	39	47
		16	20	-	32	36
CDE34,044.Wx.x	-	4 8	45	45	90	90
CDE34,058.Wx.x	-	4 8	60	60	120	120
CDE34,070.Wx.x	-	4 8	72	72	144	144
CDE34,088.Wx.x ¹⁾	-	4 8	90	90	2)	180
CDE34,108.Wx.x ¹⁾	-	4 8	110	110	2)	220
CDE34,140.Wx.x ¹⁾	-	4 8	143	143	2)	286
CDE34,168.Wx.x ¹⁾	-	4 8	170	170	2)	306
CDB34,044.Wx.x	22 kW	4	45	45	67	67
		8	45	45	52	67
CDB34,058.Wx.x	30 kW	4	60	60	90	90
		8	60	60	60	90
CDB34,070.Wx.x	37 kW	4	72	72	108	108
		8	72	72	74	108
CDB34,088.Wx.x ¹⁾	45 kW	4	90	90	2)	135
		8	90	90	2)	135
CDB34,108.Wx.x ¹⁾	55 kW	4	110	110	2)	165
		8	110	110	2)	165
CDB34,140.Wx.x ¹⁾	75 kW	4	143	143	2)	215
		8	143	143	2)	215
CDB34,168.Wx.x ¹⁾	90 kW	4	170	170	2)	255
		8	170	170	2)	255

Cooling air temperature 45 °C (40 °C CDB34,003.Cx.x)
at power stage switching frequency 4 kHz
40 °C at power stage switching frequency 8, 16 kHz

Motor cable length 10 m
Mounting height 1000 m above MSL
End-to-end mounting

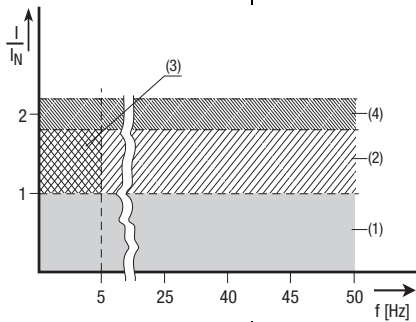
¹⁾ Devices available as from 3rd quarter 2006.

²⁾ Not available at time of going to press.

Table 3.40 Positioning drives for 400/460 V systems

3.6 c-line servo and direct drive controllers CDD3000

3.6.1 Current capacity of servo and direct drive controllers



(1) Continuous operation

(2) Intermittent* > 5 Hz rotating field frequency

Servocontrollers 2.4 A to 32 A:

$I/I_N = 1.8$ (for 30 s at 4 kHz)

$I/I_N = 1.8$ (for 30 s at 8 kHz)

$I/I_N = 1.8$ (for 30 s at 16 kHz)

Servocontrollers 45 A to 170 A:

$I/I_N = 1.5$ (for 60 s at 4 kHz)

$I/I_N = 1.5$ (for 60 s at 8 kHz)

(3) Intermittent* 0 to 5 Hz rotating field frequency

Servocontrollers 2.4 A to 32 A:

$I/I_N = 1.8$ (for 30 s at 4 kHz)

$I/I_N = 1.25-1.8$ (for 30 s at 8 kHz)

Servocontrollers 45 A to 170 A:

$I/I_N = 1.5$ (for 60 s at 4 kHz)

$I/I_N = 1-1.5$ (for 60 s at 8 kHz)

(4) Pulse mode

Servocontrollers 2.4 A to 32 A:

$I/I_N = \text{approx. } 2.2$ (at 4, 8, 16 kHz)

Servocontrollers 45 A to 170 A:

$I/I_N = \text{approx. } 1.8$ (at 4, 8 kHz)

$$*\text{Intermittent } I_N > I_{\text{eff}} \quad I_{\text{eff}} = \sqrt{\frac{1}{T} \cdot \sum_{i=1}^n I_i^2 \cdot t_i}$$

Servocontrollers for 230 V systems

Servocontroller	Device rated power output [kVA]	Switching frequency of power stage [kHz]	Rated current [A]	Peak current for intermittent mode 0 to 5 Hz [A]	Peak current for intermittent mode > 5 Hz [A]
CDD32,003.Cx.x	1.0	4	2.4	4.3	4.3
		8	2.4	4.3	4.3
		16	1.8	3.2	3.2
CDD32,004.Cx.x ¹⁾	1.6	4	4	7.2	7.2
		8	4	7.2	7.2
		16	3	5.4	5.4
CDD32,006.Cx.x ¹⁾	2.2	4	5.5	9.9	9.9
		8	5.5	9.9	9.9
		16	4.3	7.7	7.7
CDD32,008.Cx.x ¹⁾	2.8	4	7.1	12.8	12.8
		8	7.1	12.8	12.8
		16	5.5	8	9.9

Peak current for 30 s with servocontrollers 2.4 to 32 A
 Cooling air temperature: 45 °C at power stage switching frequency 4 kHz
 40 °C at power stage switching frequency 8, 16 kHz
 1) With heat sink HS3... or additional cooling surface

Mains voltage 1 x 230 V
 Motor cable length 10 m
 Mounting height 1000 m above MSL
 End-to-end mounting

Table 3.41 Positioning drives for 230 V systems

Servocontrollers for 400/460 V systems

Servocontroller	Device rated power [kVA]	Switching frequency of power stage [kHz]	Rated current I _N [A] at 400 V ²⁾	Rated current I _N [A] at 460 V ³⁾	Peak current for intermittent mode 0 to 5 Hz [A]	Peak current for intermittent mode > 5 Hz [A]
CDD34,003.Cx.x	1.5	4	2.2	2.2	4	4
		8	2.2	2.2	4	4
		16	1.0	1.0	1.1	1.8
CDD34,005.Cx.x ¹⁾	2.8	4	4.1	4.1	7.4	7.4
		8	4.1	3.6	7.4	7.4
		16	2.4	-	4.3	4.3
CDD34,006.Cx.x ¹⁾	3.9	4	5.7	5.7	10.3	10.3
		8	5.7	5.7	10.3	10.3
		16	2.6	-	4.7	4.7
CDD34,008.Wx.x	5.4	4	7.8	7.8	14	14
		8	7.8	7.8	14	14
		16	5	-	7.8	9

Table 3.42 Positioning drives for 400/460 V systems

Servocontroller	Device rated power [kVA]	Switching frequency of power stage [kHz]	Rated current I_N [A] at 400 V ²⁾	Rated current I_N [A] at 460 V ³⁾	Peak current for intermittent mode 0 to 5 Hz [A]	Peak current for intermittent mode > 5 Hz [A]
CDD34.010,Wx.x	6.9	4 8 16	10 10 6.2	10 8.8 -	18 16.5 7.8	18 18 11
CDD34.014,Wx.x	9.7	4 8 16	14 14 6.6	14 12.2 -	25 21 9.2	25 25 11.9
CDD34.017,Wx.x	11.8	4 8 16	17 17 8	17 13.5 -	31 21.2 9.2	31 31 14.4
CDD34.024,Wx.x	16.6	4 8 16	24 24 15	24 24 -	43 40 22	43 43 27
CDD34.032,Wx.x	22.2	4 8 16	32 32 20	32 28 -	58 40 22	58 58 36
CDD34.045,Cx.x	32.8	4 8	45 45	45 39	68 54	68 68
CDD34.060,Cx.x	43.8	4 8	60 60	60 52	90 71	90 90
CDD34.072,Wx.x	52.5	4 8	72 72	72 62	112 78	112 112
CDD34.090,Wx.x	65.6	4 8	90 90	90 78	135 104	135 135
CDD34.110,Wx.x	80	4 8	110 110	110 96	165 110	165 165
CDD34.143,Wx.x	104	4 8	143 143	143 124	215 143	215 215
CDD34.170,Wx.x	124	4 8	170 170	170 147	255 212	255 255
Peak current for 30 s with servocontrollers 2.4 to 32 A Peak current for 60 s with servocontroller 45 to 170 A Cooling air temperature: 45 °C at power stage switching frequency 4 kHz 40 °C at power stage switching frequency 8, 16 kHz 1) With heat sink HS3... or additional cooling surface					1) With motor cable length 10 m Mounting height 1000 m above MSL End-to-end mounting 2) Mains voltage 3 x 400 V ±10 % 3) Mains voltage 3 x 460 V ±10 %	

Table 3.42 Positioning drives for 400/460 V systems

4 Selecting the additional components

- 4.1 Selecting the line choke4-2**
 - 4.1.1 Benefits of a three-phase line choke4-4
 - 4.1.2 Line choke to conform to EN 61000-3-24-7
- 4.2 Selecting the braking resistors4-8**
- 4.3 Selecting the mains filters4-14**
 - 4.3.1 Permissible motor cable length with internal RFI filter4-14
 - 4.3.2 Permissible motor cable length with external RFI filter4-16
- 4.4 Selecting the motor choke4-19**
 - 4.4.1 Technical data4-19
 - 4.4.2 Advanced project planning rule4-20
- 4.5 Selecting the motor filters4-22**
 - 4.5.1 Technical data4-22
 - 4.5.2 Advanced project planing4-24



4.1 Selecting the line choke

Function	Effect
<ul style="list-style-type: none"> Use of the line choke reduces the voltage distortion in the system. The limit values to be observed for variable-speed power drives are laid down in the standards EN61800-3 and IEC1800-3. Of course, the line choke also offers protection against transient system voltage peaks. 	<ul style="list-style-type: none"> Reduction of voltage distortion (THD)¹ Reduction of commutation notches Reduction of the amplitude of the line charging current Increase in service life of the DC-link capacitors (electrolytic capacitors) Attenuation of transient voltage peaks from contaminated systems

1) THD = Total Harmonic Distortion



Use of the line choke is necessary:

- Where the drive controllers are used in industrial systems of environment class 3, as per EN 61000-2-4 and above (hostile industrial environment).

Characteristics of environment class 3 include:

- Mains voltage fluctuations $> \pm 10\% U_N$
- Short-time interruptions between 10 ms and 60 s
- Mains voltage asymmetry $> 3\%$

Environment class 3 typically applies where:

- a major part of the load is supplied by power converters (dc choppers or soft-start equipment),
 - welding machines are present,
 - induction or arc furnaces are present,
 - large motors are started frequently and
 - loads fluctuate rapidly.
- To comply with the limit values (standard (EN 61800-3) for variable-speed power drives (PDS's) intended for use in industrial environments (2nd environment). Verification can only be provided by on-site measurements.

For basic principles and definitions of terms on this subject refer to section 5.3.

- With a dc-link between multiple drive controllers. For more information on this subject refer to section 3.2.21 "DC network operation".

4. For operation of higher-powered drive controllers, such as the CDA3000 and CDD3000 series above 30 kW.
 5. If the CDE/CDB3000 drive controller series above 22 kW are operated with external mains filters. For precise data refer to the applicable operation manual.
-

1

2

3

4

5

6

A

4.1.1 Benefits of a three-phase line choke



In the following the example of a 4 kW drive controller is taken to demonstrate the benefits to the application of using a three-phase line choke with 4 % short-circuit voltage.

A line impedance of 0.6 mH was assumed for the calculation. This value results from IEC1800-3 para. 6.1.2 (short-circuit current of system = 250 times fundamental current of load).

For the calculation when using a line choke a total line impedance of 6 mH was assumed. This value results from IEC1800-3 para. 6.1.2 and from the use of a line choke with 4 % short-circuit voltage (U_K).

Harmonics load

Harmonic	Percentage without line choke	Percentage with line choke	Amplitude without line choke	Amplitude with line choke
1 (fundamental)	100 %	100 %	8.58 A	8.31 A
5	76 %	30 %	6.4 A	2.55 A
7	57 %	8.9 %	4.9 A	0.74 A
11	21 %	6 %	1.85 A	0.5 A
13 to 41	36 %	10.9 %	3.15 A	0.91 A

Table 4.1 Percentage shares of currents due to harmonics based on the example of a 4 kW drive controller

System load

	Without line choke		With line choke		Change
	4 kW drive controller, line impedance 0.6 mH		4 kW drive controller, line impedance 6 mH		Without line choke / With line choke
Voltage distortion (THD)	99 %		33 %		-67 %
Mains current amplitude	18.9 A		9.7 A		-48 %
Mains current effective	8.5 A		6.23 A		-27 %
Commutation notches referred to the mains voltage	28 V		8 V		-70%
Life of the DC-link capacitors (electrolytic capacitors)	Nominal life		2 to 3 times nominal life		+200 to 300 %

Table 4.2 Change in system load resulting from insertion of a power choke with 4 % short-circuit voltage based on the example of a 4 kW drive controller



The total voltage distortion THD is calculated from the individual harmonics according to the following formula:

$$THD = \frac{\sqrt{U_5^2 + U_7^2 + \dots + U_{41}^2}}{U_{eff}} \quad U_n \text{ as \% of } U_{fundamental}$$

Mains voltage asymmetry

	Without line choke			With line choke		
	4 kW drive controller, line impedance 0.6 mH			4 kW drive controller, line impedance 6 mH		
Mains voltage asymmetry	0 %	+3 %	-3 %	0 %	+3 %	-3 %
Mains current amplitude	18.9 A	25.4 A	25.1 A	9.7 A	10.7 A	11 A
Mains current effective	8.5 A	10.5 A	10.2 A	6.2 A	6.7 A	6.8 A

Table 4.3 Effect of the power choke with asymmetrical mains voltage based on the example of a 4 kW drive controller



According to IEC1000-2-4 the mains voltage asymmetry may be only 2 %.

In summary

The example shows that the benefit of a line choke with 4 % short-circuit voltage is wide-ranging, and so it should not be omitted from any machine or system.



In the CDE/CDB3000 drive controllers above 22 kW/44 A, no electrolytic capacitors are used in the DC link. The devices are fitted with a slim DC link made of metal-plastic-propylene capacitors.

The drive controllers with MPP capacitors cause lower mains charging currents and mains feedback.

Subject	CDA/D3000 (22 - 37 kW)	CDE/B3000 (22 - 37 kW)
Capacitors used	Electrolytic capacitors	Metal plastic propylene (MPP) capacitors (foil capacitors)
General everyday usage	Electrolytic capacitors - D.C.-link (thick D.C.-link)	Narrow D.C.-link
Capacitor lifetime	Limited, 20.000 to 60.000 hours depending on application	> 100.000 hours
Temperature resistance	normal	Higher temperature resistance than electrolytic capacitors
Dielectric strength	normal	Increased surge voltage endurance and self-healing
System perturbation	The 5th harmonic of the current can be limited to approx. 35% by means of the power choke	The 5th harmonic of the current can be limited to approx. 25 % by means of the power choke
ZK ripple	normal	Higher ripple than with electrolytic capacitor D.C.-link

Table 4.4 D.C.-link concepts

4.1.2 Line choke to conform to EN 61000-3-2

Drive controllers, positioning drives and servocontrollers are "professional devices" under the terms of EN 61000, so that at a rated power output of ≤ 1 kW they fall within the scope of the standard.

Where 1-phase drive units of ≤ 1 kW are connected directly to the public low-voltage system (environment 1), either measures to conform to the standard must be taken or the responsible utility company must issue a connection permit.

The following table shows the maximum permissible amplitudes of the current harmonics for 1-phase drive units with connected loads ≤ 1 kW, to EN 61000-3-2.

Order of harmonics	Permissible limit [A]
3	2.30
5	1.14
7	0.77
9	0.40
11	0.33
13	0.21
15	0.15
17	0.13

Table 4.5 Max. permissible amplitudes of current harmonics

Conformance to EN 61000-3-2 with line choke

Conformance to EN 61000-3-2 is possible up to a rated motor power output of about 550 W (4-pole standard motor). For this you must use a single-phase line choke (e.g. type: LR32.5) with 6 %¹⁾ short-circuit voltage.



Attention: For single-phase PWM drive controllers with connected loads >550 W, conformance to EN 61000-3-2 is only possible if an active mains rectifier is deployed for sinusoidal mains current tapping. In practice, this means using PWM drive controllers with a so-called PFC²⁾ (Power Factor Controller).

1) UK = 6 % at 230 V = 13.8 V

2) A PFC is designed according to the principle of a step-up converter. A characteristic of an active input configuration of this kind is that the output voltage of the PFC is always higher than the (system) input voltage.

4.2 Selecting the braking resistors

During regenerative operation, e.g. when applying the brake to the drive, the motor returns energy to the drive controller. This increases the voltage in the DC link. If the voltage exceeds a permissible value, the internal braking transistor is activated and the regenerative energy is converted into heat by way of the externally connected braking resistor.

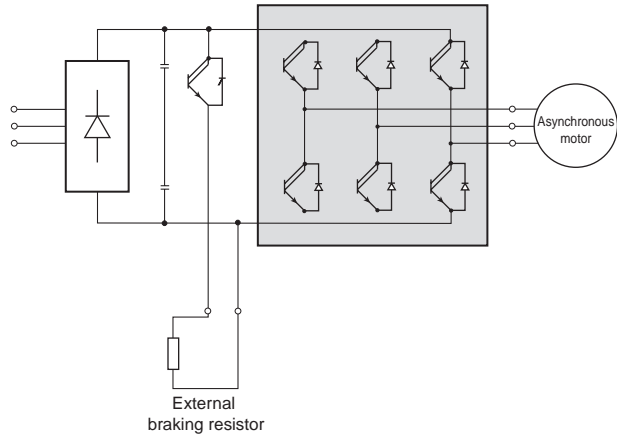


Figure 4.1 Block diagram of a drive controller with braking chopper

Technical data	Design	as per diagram A1 and A11	as per diagram A2	as per diagram A3 and A4
Surface temperature		> 200 °C	80 °C	80 °C
Touch protection		No	Yes (< 80 °C)	Yes (< 80 °C)
voltage		max. 800 V	max. 800 V	max. 800 V
High-voltage strength		4000 V	4000 V	1800 V
Temperature monitoring		Yes, with bimetallic protector (breaking capacity 0.5 A/ 230 V)		
Acceptance tests		CE-conformant		
UL Recognition		On request		No
Connection		1 m long PTFE-insulated litz wire	Ceramic terminals	Ceramic terminals
Diagrams				

Braking resistor						
Tech.data Order ref.	Cont. braking power [W]	Resistance ⁶⁾ [$\Omega \pm 10\%$]	Peak braking power [W]		Protection	Diagram
			390 VDC ¹⁾	750 VDC ²⁾		
BR-270.01, 540 ⁴⁾	35	270 (243)	560	2080	IP23	A11
BR-160.01, 540 ⁴⁾	35	160 (144)	950	3)	IP23	A11
BR-090.01, 540 ⁴⁾	35	90 (81)	1690	3)	IP23	A11
BR-110.01, 540 ⁴⁾	35	110 (99)	1380	3)	IP23	A11
BR-110.02, 540 ⁴⁾	150	110 (99)	1380	5110	IP23	A1
BR-200.02, 540 ⁴⁾	150	200 (180)	760	2810	IP23	A1
BR-270.02, 540 ⁴⁾	150	270 (243)	560	2080	IP23	A1
BR-160.02, 540 ⁴⁾	150	160 (144)	950	3500	IP23	A1
BR-110.03, 541	300	110 (99)	1380	5110	IP23 ⁵⁾	A2
BR-200.03, 541	300	200 (180)	760	2810	IP23 ⁵⁾	A2
BR-270.03, 541	300	270 (243)	560	2080	IP23 ⁵⁾	A2
BR-160.03, 541	300	160 (144)	950	3500	IP23 ⁵⁾	A2
BR-090.03, 541	300	90 (81)	1690	6250	IP23 ⁵⁾	A2
BR-090.10, 201	1000	90 (81)	1690	6250	IP20	A3
BR-090.10, 541	1000	90 (81)	1690	6250	IP23 ⁵⁾	A4
BR-042.20, 201	2000	42 (37.5)	-	13390	IP20	A3
BR-042.20, 541	2000	42 (37.5)	-	13390	IP23 ⁵⁾	A4
BR-015.60, 541	6000	15 (13.5)	-	37500	IP23 ⁵⁾	A4
BR-010.80, 541	8000	10 (9)	-	56250	IP23 ⁵⁾	A4



When selecting the braking resistors, it must be ensured that for c-line DRIVES drive controllers the minimum permissible resistance load is specified without further tolerance.

- 1) 1 x 230 V mains connection -20 % +15 %
- 2) 3 x 460 V mains connection -25 % +10 %
- 3) Not permitted for operation on inverter modules with 3 x 400/460 V mains connection
- 4) The braking resistors can be operated at double continuous braking power if provided with optimum cooling.
Consult your project engineer.
- 5) Adapter box in IP54
- 6) Specify minimum resistance in brackets



Special designs in different lengths with different terminals and/or multiple modules are also available on request.

Calculation of effective braking power

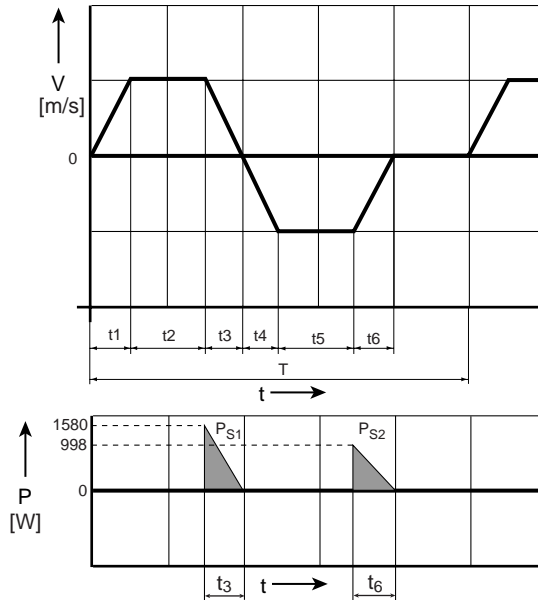


Figure 4.2 Effective braking power

$$P_D = \frac{t_3 + t_6}{T} \cdot \frac{P_{S1} + P_{S2}}{2} = [W]$$

P_S = Peak braking power

P_D = Continuous braking power

T = Sampling time (work cycle)

t_1 = 0.2 s

t_2 = 3 s

t_3 = 0.2 s

t_4 = 0.2 s

t_5 = 3 s

t_6 = 0.2 s

T = 8.4 s



The sampling time T must be < 150 s.

Example: Calculation example for Figure 4.2

- Drive controller CDA34.005
- Minimum ohmic resistance
of an external braking resistor 180 Ω
- Load cycle see Figure 4.2

1. Calculation

$$P_D = \frac{t_3 + t_6}{T} \cdot \frac{P_{S1} + P_{S2}}{2}$$

$$P_D = \frac{0.2s + 0.2s}{8.4s} \cdot \frac{1580W + 998W}{2} = 61.4 W$$

2. Choice of braking resistor

Braking resistor BR-270.02,540 was chosen

Peak braking power: 2080 W
 Continuous braking power: 150 W
 Minimum resistance: 243 Ω (270 Ω - 10 %)



The resistance must not be less than the minimum ohmic connected load permitted by the inverter module.



For definition of continuous breaking power of the drive controller with integrated braking resistor, please see chapter 3.2.22.

Parallel/series configuration of braking resistors

By means of a parallel configuration of braking resistors the peak braking power can be adapted to the specific application.

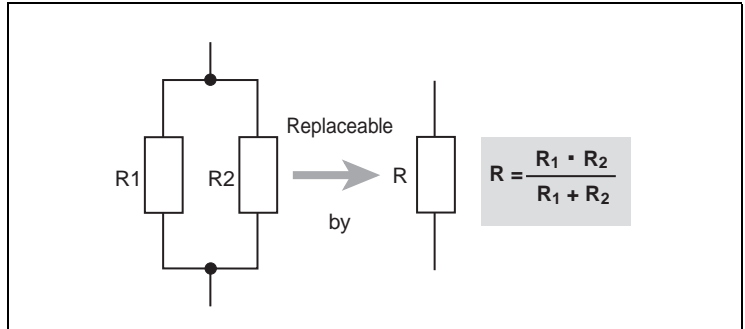


Figure 4.3 Parallel configuration of two resistors

By means of a series configuration the continuous braking power can be adapted to the specific application.

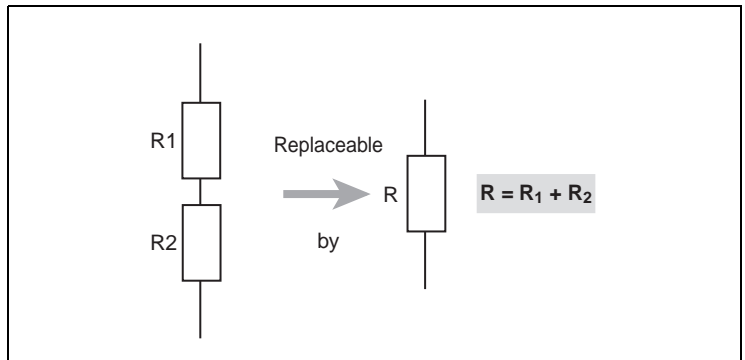


Figure 4.4 Parallel configuration of two resistors

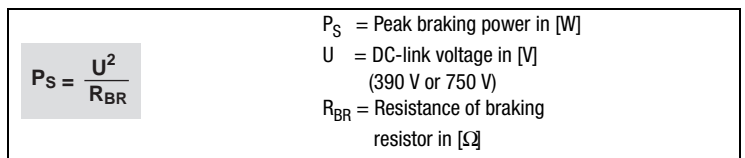


Figure 4.5 Calculation of peak braking power

4.3 Selecting the mains filters

For details on the subject of electromagnetic compatibility (EMC) refer to section 5.5.

4.3.1 Permissible motor cable length with internal RFI filter

Drive controller	4 kHz power stage clock frequency		8 kHz power stage clock frequency		16 kHz power stage clock frequency	
	With integral mains filter		With integral mains filter		With integral mains filter	
	Industrial	Residential	Industrial	Residential	Industrial	Residential
CDE/B32.003	1)	1)	20	10	25	10
CDE/B32.004	1)	1)	20	10	25	10
CDE/B32.006	25	10	20	10	25	10
CDE/B32.008	25	10	20	10	25	10
CDE/B34.003	10	10	25	10	1)	1)
CDE/B34.005	10	10	25	10	25	1)
CDE/B34.006	10	10	25	10	25	1)
CDE/B34.008	25	10	25	10	25	1)
CDE/B34.010	25	10	25	10	25	1)
CDE/B34.014	1)	10	25	10 ²⁾	25	1)
CDE/B34.017	1)	10	25	10 ²⁾	25	1)
CDE/B34.044	25	10	25	10	-	-
CDE/B34.058	25	10	25	10	-	-
CDE/B34.070	25	10	25	10	-	-

Table 4.6 Permissible motor cable length with integral mains filter dependent on standard 61800-3

Explanatory notes on Table 4.6

Residential	Limit to EN 61800-3 (category C2), restricted availability. For more information on this subject refer to section 5.5. Maximum permissible motor cable length at which the interference emission (>9 kHz) is below the permissible limits. Only 10 metres was checked in the measurements.
Industrial:	Limit to EN 61800-3 (category C3), restricted availability. For more information on this subject refer to section 5.5. Maximum permissible motor cable length at which the interference emission (>9 kHz) is below the permissible limits. Only 25 metres was checked in the measurements.
1)	The interference emission at 10 and/or 25 metres was above the limits stipulated by the standard. This does not mean, however, that the mains filter is not working, but merely that it is not working optimally across the full frequency band. To conform to the standard, therefore, an external mains filter must be used.
2)	To conform to the standard, line chokes ($u_K=4\%$) must be set.
12 kHz power stage clock frequency	At 12 kHz power stage clock frequency external mains filters must be used, as no measurement results with an internal mains filter are available.
Measurement method:	The permissible length of the motor cable was determined according to the standard (stipulated measurement method) - see section 5.5.3.



Always follow the installation rules set out in the operation manuals.

4.3.2 Permissible motor cable length with external RFI filter

Ambient conditions	EMCxx.x
Rated voltage	3 x 480 V, max. +10 %, 50/60 Hz
Ambient temperature	typically -25 °C to +40 °C, with power reduction up to 60 °C (1.3 %/°C)
Mounting height	1000 m, with power reduction up to 4000 m (6 %/1000 m)
Relative air humidity	15 ... 85 %, condensation not permitted
Storage/transportation temperature	-25 °C to +70 °C/-40 °C to +85 °C
Protection	IP00, input terminals VBG4
Permissible contamination	P2 to EN 61558-1
UL Recognition	All mains filters have UL recognition for the US and Canadian markets.
RFI suppression to EN61800-3 (residential, category C2)	Motor cable length up to 100 m permitted
RFI suppression to EN61800-3 (industrial, category C3)	Motor cable length up to 150 m permitted



Hinweis: Use of external RFI filters also enables category C1 to be attained with shorter motor cable lengths. If this is important to you, talk to our sales engineers or your project engineer.

Three-phase mains filters for side mounting						
Order ref.	Tech.data Suitable for drive controllers	Rated current [A]	Total power loss [W]	Leakage current [mA]	Weight [kg]	Terminals [mm ²]
EMC 10.0	CDA/CDD/CDE/CDB34.008 CDA/CDD/CDE/CDB34.010	10	13	< 1.2	1.7	0.2...4, PE M5
EMC 17.0	CDA/CDD/CDE/CDB34.014 CDA/CDD/CDE/CDB34.017	17	21	< 1.5	1.8	0.2...4, PE M5
EMC 35.0	CDA/CDD/CDE/CDB34.024 CDA/CDD/CDE/CDB34.032	35	27	< 1.2	2.5	0.2...6, PE M5
EMC 50.0	CDA/CDD/CDE/CDB34.044 ^{1) 2)} CDA/CDD/CDE/CDB34.045 ^{1) 2)}	50	31	< 1.6	3.4	0.5...16, PE M5
EMC 63.0	CDA/CDD/CDE/CDB34.058 ^{1) 2)} CDA/CDD/CDE/CDB34.060 ^{1) 2)}	63	53	< 5.5	6.0	0.5...16, PE M6
EMC 80.0	CDA/CDD/CDE/CDB34.070 ^{1) 2)} CDA/CDD/CDE/CDB34.072 ^{1) 2)}	80	68	< 10	6.0	0.75...35, PE M8
EMC 100.0	CDA/CDD34.090 ¹⁾	100	68	< 10	6.0	0.75...35, PE M8
EMC 125.0	CDA/CDD34.110 ¹⁾	125	82	< 10	10.0	16...50, PE M10
EMC 150.0	CDA/CDD34.143 ¹⁾	150	88	< 10	10.0	35...95, PE M10
EMC 180.0	CDA/CDD34.170 ¹⁾	180	150	< 13	15.5	Pin M12
EMC 250.0	CDA34.250 ¹⁾	250	180	< 13	18.2	Pin M12

1) The drive controllers (CDA34.045 to CDA34.250) must be operated with line chokes.
2) Because of the precharging technology, in the case of drive controller CDE/CDB3000 it must be ensured that the line choke is installed between the drive controller and the mains filter, otherwise the mains filter may be damaged.



Always follow the installation rules set out in the operation manuals.

Extract from CDE/CDB3000 operation manual

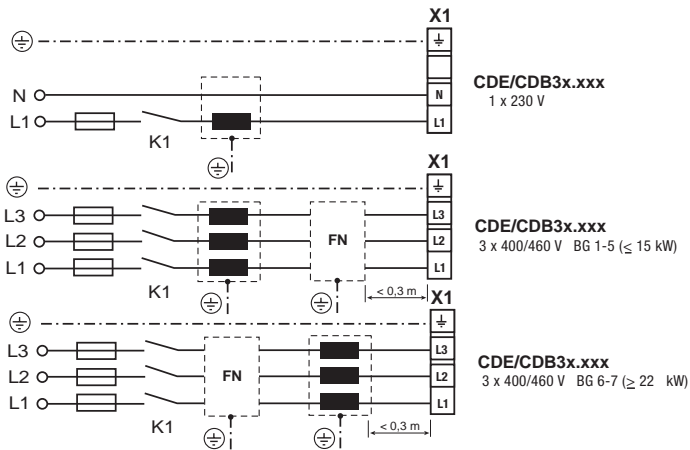


Figure 4.6 Mains connection



Attention: Because of the precharging technology in sizes 6 and 7 (≥ 22 kW) it must be ensured that the line choke is installed between the drive controller and the mains filter, otherwise the mains filter may be damaged.



Attention: Danger to life! Never wire or disconnect electrical connections while they are live! Before working on the device disconnect the power. Wait until the DC-link voltage at terminals X1/L+ and L- (size 1-5) and X21/ DC+, DC- (size 6-7) has fallen to the safety-low voltage before working on the device (approx. 10 min.).

4.4 Selecting the motor choke

Function	Effect
<ul style="list-style-type: none"> Use of the motor choke reduces the voltage steepness (du/dt) on the motor terminals. The motor choke also suppresses interference caused by switching in the motor cable. 	<ul style="list-style-type: none"> Reduces the voltage steepness (du/dt) on the motor winding to <1000 V/μs (typically approx. 4000/μs). Reduces the switch overvoltage caused by switching in the motor cable.

4.4.1 Technical data

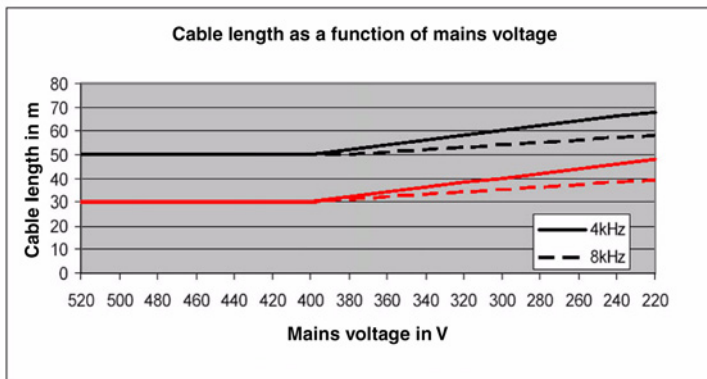
Ambient conditions	MR34.xxx
Rated voltage	3 x 460 V, +10 %
Overload factor	1.8 x I _N for 40 s up to rated current 32 A 1.5 x I _N for 60 s at rated current 45 to 170 A
Ambient temperature	-25 °C to +45 °C, with power reduction up to 60 °C (2.5 % /°C)
Mounting height	1000 m, with power reduction to 2000 m (12.5 %/1000 m)
Relative air humidity	15 ... 85 %, condensation not permitted
Storage temperature	-25 °C to +70 °C
Protection	IP00, terminals VBG4
Permissible contamination	P2 to EN 61558-1, vertical wall mounting
Connections	Up to type MR34.24 screw-type terminals, larger motor chokes flat connection with threaded bolt
UL Recognition	All motor chokes have UL recognition for the US and Canadian markets.
Power stage rotating field frequency/clock frequency	max. 150 Hz/ 4 to 8 kHz
Standstill torque (rotating field zero)	every 120 s, max. 5 s
du/dt	typically < 1000 V/μs

Motor choke							
Tech.data	Suitable for drive controllers	Rated current [A]	Power loss [W]	Motor cable max. length [m]	Max. capacitance per unit length [pF/m]	Inductance [mH]	Weight [kg]
Order ref.							
MR34.10	CDA32.004 to CDA34.010	9.4	70	30	L - L = 140 L - Screen = 210	0.9	4.5
MR34.24	CDA34.014 to CDA34.024	24	120	50	L - L = 140 L - Screen = 210	0.45	10
MR34.45	CDA34.032 CDA34.045	46	130	50	L - L = 170 L - Screen = 260	0.15	10.3
MR34.90	CDA34.060 to CDA34.090	91	145	30	L - L = 190 L - Screen = 300	0.05	10.5
MR34.110	CDA34.110	150	160	50	L - L = 190 L - Screen = 300	0.05	20
MR34.170	CDA34.143 CDA34.170	176	210	30	L - L = 190 L - Screen = 300	0.05	28

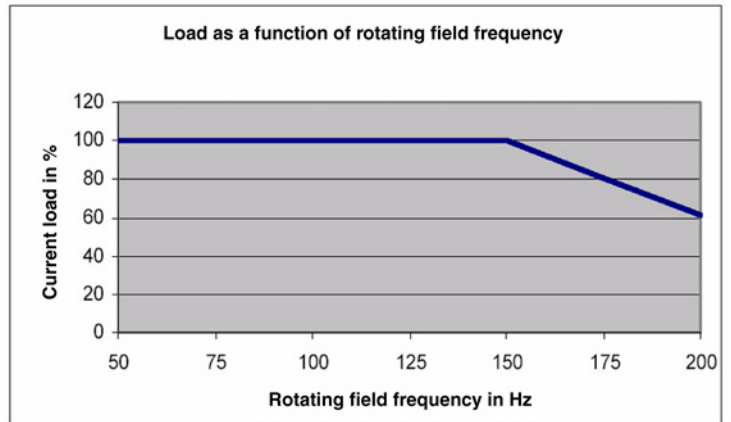
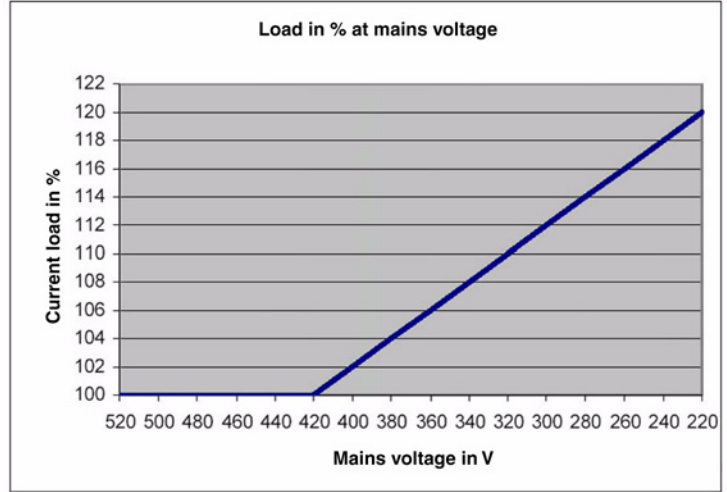


The short-circuit voltage of the motor choke is 2 % to 5 % of the rated voltage. At a rotating field frequency of 50 Hz the short-circuit voltage is approximately 2 %.

4.4.2 Advanced project planning rule



When using a low-capacitance motor cable (type: Prototflex/Siemens) the permissible motor cable length may be multiplied by the factor 1.4 (50 m x 1.4 = 70 m).



Special designs are also available on request.

4.5 Selecting the motor filters

Function	Effect
<ul style="list-style-type: none"> Use of the motor filter generates a sinusoidal output voltage with low ripple voltage (typically approx. 10 V). 	<p>The motor filter reduces:</p> <ul style="list-style-type: none"> the du/dt voltage load on motor winding, the noise in the motor winding, the leakage currents (conductor-earth voltage) by around half, the switching overvoltage caused by switching in the motor cable, the bearing currents which may occur as a result of high-frequency common-mode voltages.

4.5.1 Technical data

Ambient conditions	MRF34.xxx
Version	Motor choke with capacitor for drive controller to EN 61558, VDE0570
Rated voltage	3 x 460 V, +10 %
Overload factor	1.8 x I _N for 40 s up to rated current 32 A 1.5 x I _N for 60 s at rated current 45 to 250 A
Ambient temperature	-25 °C to +45 °C, with power reduction up to 60 °C (2.5 % /°C)
Mounting height	1000 m, with power reduction to 2000 m (7.5 %/1000 m)
Relative air humidity	15 ... 85 %, condensation not permitted
Storage temperature	-25 °C to +70 °C
Protection / Connections	IP00, terminals VBG4 / screw terminals
Permissible contamination	P2 to EN 61558-1, vertical wall mounting
UL Recognition	All motor filters have UL recognition for the US and Canadian markets.
Power stage rotating field frequency/clock frequency	max. 150 Hz at 4 to 8 kHz
Standstill torque (rotating field zero)	max. 5 s, every 120 s
Motor cable length, shielded	max. 250 m
Output voltage	Sinusoidal with low, overlaid ripple voltage

Motor filter						
Tech.data Order ref.	Suitable for drive controllers	Rated current [A]	Power loss [W]	Max. capacitance per unit length of motor cable [pF/m]	Connection cross-section [mm ²]	Weight [kg]
MRF34.10	CDA32.004 to CDA34.010	10	70	L - L = 140 L - Screen = 210	4	5.5
MRF34.17	CDA34.014	16.5	120		10	8.5
MRF34.24	CDA34.024	24	150	L - L = 170 L - Screen = 260	16	14.5
MRF34.32	CDAA34.032	32	170		16	19
MRF34.45	CDA34.045	48	190	L - L = 190 L - Screen = 300	16	25.5
MRF34.60	CDA34.060	61	220		35	33.5
MRF34.72	CDA34.072	72	250	L - L = 190 L - Screen = 300	35	37
MRF34.90	CDA34.090	90	290		50	53
MRF34.110	CDA34.110	115	350	L - L = 190 L - Screen = 300	95	66
MRF34.170	CDA34.143 CDA34.170	180	450		150	75



The short-circuit voltage of the motor filter is approximately 4-8 % of the rated voltage. At a rotating field frequency of 50 Hz the short-circuit voltage is approximately 3 %, with an increase in power factor of around 2 %.

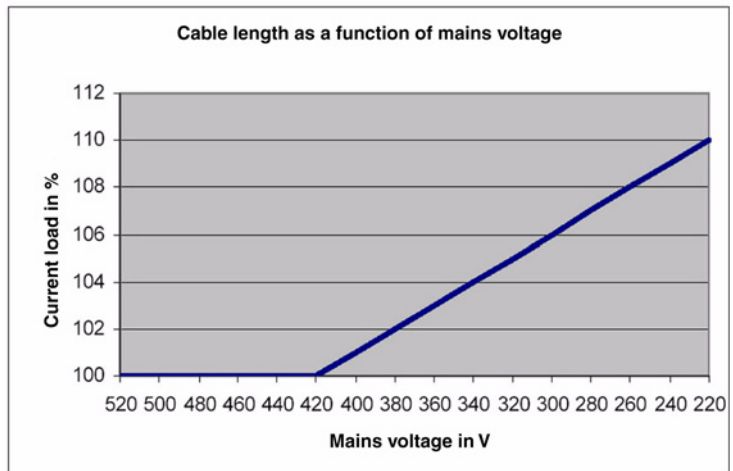
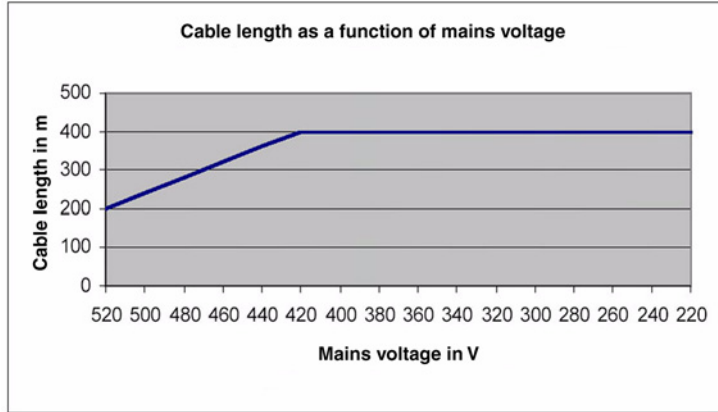
Further project planning notes:

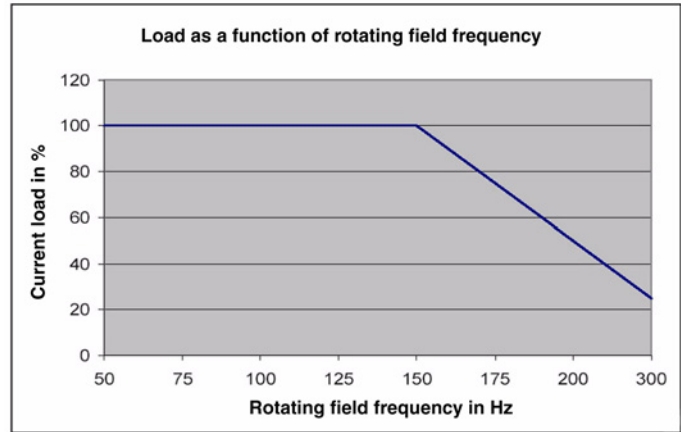
- For initial charging of the capacitors an additional approximately 10 % of the motor filter rated current is required. It must be ensured that the current injection and start-up current is reduced accordingly.
- Motor identification must **not** be performed with MRF34.xxx. Disconnect motor choke during identification.
- The motor filter may only be used in VFC (Voltage Frequency Control) mode.

4.5.2 Advanced project planing



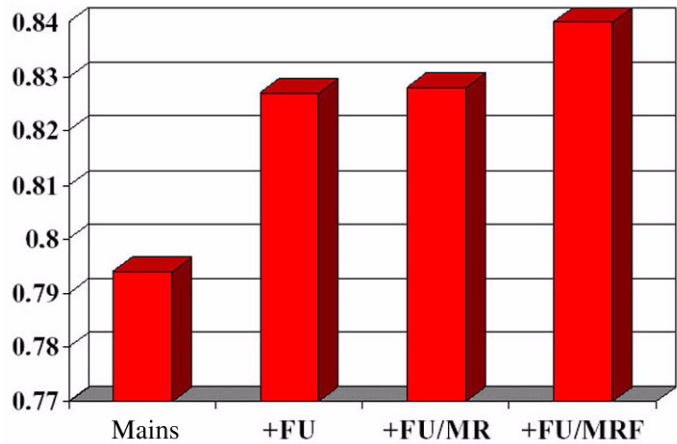
When using a low-capacitance motor cable (type: Prototflex/Siemens) the permissible motor cable length may be multiplied by the factor 1.4 (400 m x 1.4 = 560 m).





Improvement in motor power factor by using motor filter MRF34.xxx

- Example measurement on a 15 kW motor in part load range

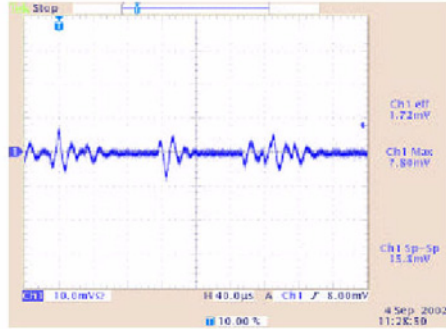
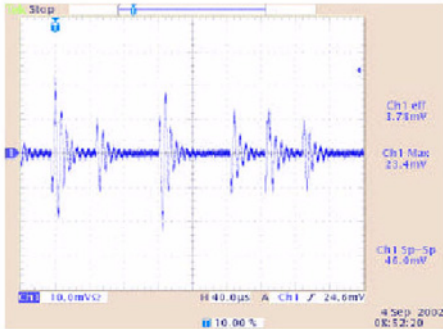


Reduction in leakage current by using motor filter MRF34.xxx

- The leakage current caused by the PWM clock signal and the capacitance per unit length of the motor cable in the motor cable screen is greatly reduced (halved) by using a motor filter.

Typical leakage current with 50 m motor cable, without motor filter MRF 1.89 Aeff/23 App

Typical leakage current with 50 m motor cable, with motor filter MRF 0.86 Aeff/7.9 App



Calculation of leakage current per m:

Without motor filter: $1.89 \text{ A} / 50 \text{ m} = 38 \text{ mA}$
 with motor filter: $0.86 \text{ A} / 50 \text{ m} = 17 \text{ mA}$

With motor filter the leakage current drops by approx. 55% per meter.

Reduction in emitted interference spectrum (unscreened motor cables) by motor filter MRF

- Only unscreened motor cables and the motor were assessed.
- As in practice, the drive controller and filter are mounted in the cabinet, outside the reception range.

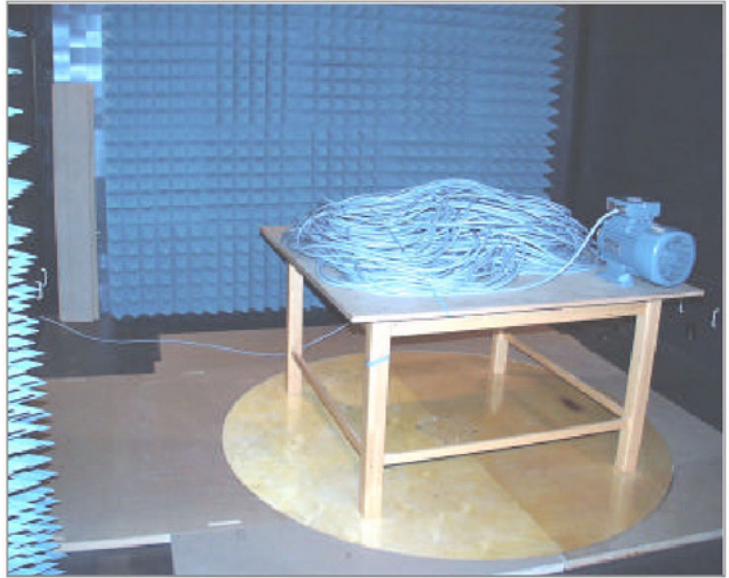


Figure 4.7 Measurement set-up

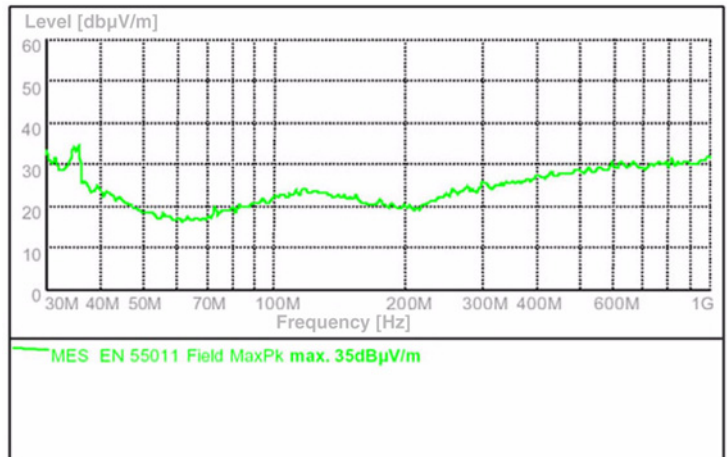


Figure 4.8 Interference spectrum of a 50 metre long screened motor cable (without motor filter)

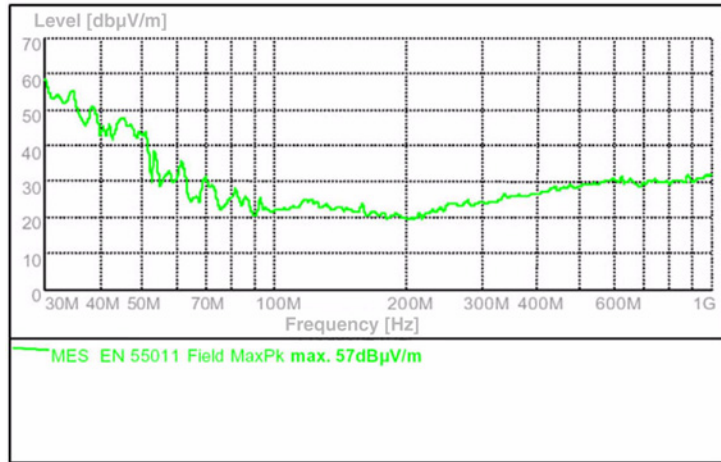


Figure 4.9 Interference spectrum of a 50 metre long unscreened motor cable (without motor filter)

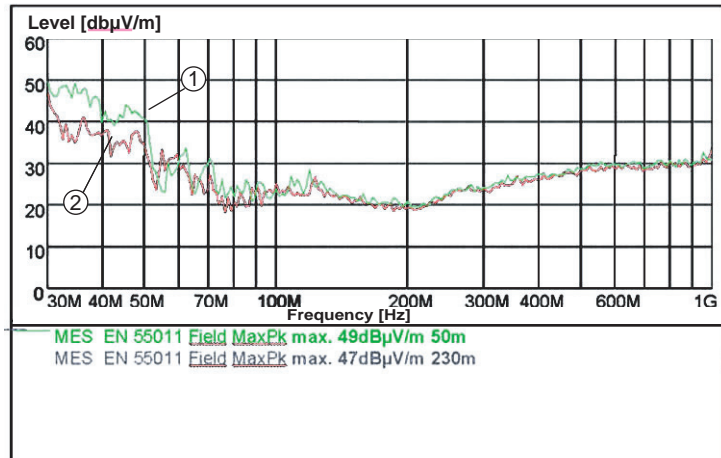


Figure 4.10 Interference spectrum of a 50 m (1) / 230 m (2) long unscreened motor cable, when operating with motor filter (MRF)



Special designs are also available on request.

5 Information on system design

5.1	Heat discharge from the switch cabinet	5-3
5.1.1	Basic terms for calculation	5-3
5.1.2	Effective cabinet surface	5-5
5.1.3	Calculation of filter fans	5-7
5.1.4	Calculation of heat exchangers	5-8
5.2	Heat transfer by conduction	5-9
5.2.1	Calculation example with CDA34.014, C (Cold Plate)	5-11
5.3	System feedback of power drives	5-16
5.3.1	Reducing system feedback	5-20
5.4	Reactive current compensation systems in electric power systems with non-linear loads	5-22
5.4.1	Resonance frequency in electric power systems	5-24
5.5	Electromagnetic compatibility (EMC) and power drives	5-26
5.5.1	EMC standardization of power drives	5-27
5.5.2	Limit curve for power drives (PDS's)	5-34
5.5.3	Typical measurement set-up for acceptance testing of power drives	5-35
5.5.4	Installation guidelines for switch cabinets	5-41
5.5.5	Sixteen EMC measures to DIN VDE 0100 part 440	5-43
5.6	Safety engineering for machines with power drives	5-45
5.6.1	Guidelines and EN norm group	5-48

5.6.2	Risk assessment and reduction	5-50
5.6.3	"Safe Standstill" to EN 954-1 category 3	5-52
5.6.4	Safety functions for movement control	5-63
5.6.5	Application of future EN ISO 13849-1 (EN 954-1) and EN IEC 62061	5-67
5.7	Drive controller fed power drives in areas subject to explosion hazards	5-76
5.7.1	Motors of protection category "d"	5-77
5.7.2	Protection measures	5-79
5.8	Fault current monitoring in electrical installations with power drive systems	5-82
5.8.1	Basic measurement method for RCMs/RCDs (type A)	5-85 5-84
5.8.2	All-current sensitive fault current breaker monitoring (RCM, type B) in earthed systems	5-84
5.8.3	All-current sensitive residual current monitoring in passenger and goods lifts	5-87

5.1 Heat discharge from the switch cabinet

5.1.1 Basic terms for calculation

A number of calculations must be carried out in order to be able to dimension the air-conditioning components correctly. The following variables are key to the calculations:

Basic terms	Explanations
Q_V [Watt]	Power loss (heat output) of the electrical components installed in the switch cabinet.
Q_S [Watt]	Heat irradiated inwards or emitted outwards via the effective switch cabinet surface (to VDE 0660 part 500). If the interior temperature of the cabinet is higher than the ambient temperature ($T_i > T_u$), heat is emitted from the cabinet. ($Q_S > 0$). If the ambient temperature is higher than the interior temperature ($T_i < T_u$), heat is radiated into the cabinet ($Q_S < 0$).
Q_E [Watt]	Necessary cooling power of an air-conditioning component; this refers to the heat output which the device must discharge from the switch cabinet.
Q_H [Watt]	Necessary heat output of a switch cabinet heater.
T_i [°C]	Maximum permissible cabinet interior temperature specified by the manufacturers of the electrical components. As a rule it is between +35 °C and +45 °C.
T_u [°C]	Maximum ambient temperature at which fault-free functioning of all electronic components in the switch cabinet or electronics housing must still be guaranteed.
V [m³/h]	Necessary volumetric flow of a filter fan.
A [m²]	Effective switch cabinet surface calculated according to DIN 57 660 Part 500 / VDE 0660 Part 500.
k [W/m²K]	Heat transfer coefficient of the switch cabinet. It is defined by the following equation: $k = \frac{l}{\frac{l}{\alpha_i} + \frac{s}{\lambda} + \frac{l}{\alpha_a}} \quad k_{\text{sheet-steel}} = 5.5 \text{ W/m}^2\text{k}$

Table 5.1 Basic terms for calculation

In this, α_i and α_a designate the heat transfer coefficients for the inner and outer wall respectively; λ designates the heat transfer coefficient of the wall material and s the wall thickness.

$$R = \frac{1}{k} \left[\frac{\text{m}^2 \text{K}}{\text{W}} \right]$$

Heat transfer resistance of the switch cabinet.

5.1.2 Effective cabinet surface

Of the variables cited above, the effective switch cabinet surface A requires a special note of explanation: The heat output emitted from the switch cabinet is not only dependent on its actual surface area; the mode of installation of the cabinet is also decisive. A housing standing free and open on all sides can emit more heat than one mounted on a wall or in a niche. For that reason there are precise regulations as to how the effective switch cabinet surface is to be calculated dependent on the mode of installation. The formulae to calculate A are laid down in DIN 57660 Part 500 / VDE 0660 DIN 500 (see Figure 5.1).

Enclosure installation mode to VDE 0660 part 500	
Installation mode to VDE 0660/500	Formula for calculating A [m ²]
<input type="checkbox"/>	$A = 1.8 \times H \times (W+D) + 1.4 \times W \times D$
<input type="checkbox"/>	$A = 1.4 \times W \times (H+D) + 1.8 \times D \times H$
<input type="checkbox"/>	$A = 1.4 \times D \times (H+W) + 1.8 \times W \times H$
<input type="checkbox"/>	$A = 1.4 \times H \times (W+D) + 1.4 \times W \times D$
<input type="checkbox"/>	$A = 1.8 \times W \times H + 1.4 \times W \times D + D \times H$
<input type="checkbox"/>	$A = 1.4 \times W \times (H+D) + D \times H$
<input type="checkbox"/>	$A = 1.4 \times W \times H + 0.7 \times W \times D + D \times H$

<input type="checkbox"/> Single housing free-standing on all sides	<input type="checkbox"/> Centre housing free-standing
<input type="checkbox"/> Single housing for wall mounting	<input type="checkbox"/> Centre housing for wall mounting
<input type="checkbox"/> Start or end housing free-standing	<input type="checkbox"/> Centre housing for wall mounting, covered top areas
<input type="checkbox"/> Start or end housing for wall mounting	

W = Cabinet width [m] H = Cabinet height [m] D = Cabinet depth [m]

Figure 5.1 Calculation of the effective emitting switch cabinet surface

Radiated power of a switch cabinet surface

If the effective switch cabinet surface A and the heat transfer coefficient k are known, the radiated power Q_S at maximum cabinet interior temperature T_i and maximum outside temperature T_u can be calculated as follows:

$$Q_S = k \cdot A \cdot (T_i - T_u) \quad (1)$$



The formula (1) applies only if internal movement of air is ensured. T_i corresponds to the mean cabinet interior temperature which can be safeguarded only by an internal circulation fan with the cabinet closed.

There are also diagrams from which the radiated power can be read directly, without calculation (see Figure 5.2).

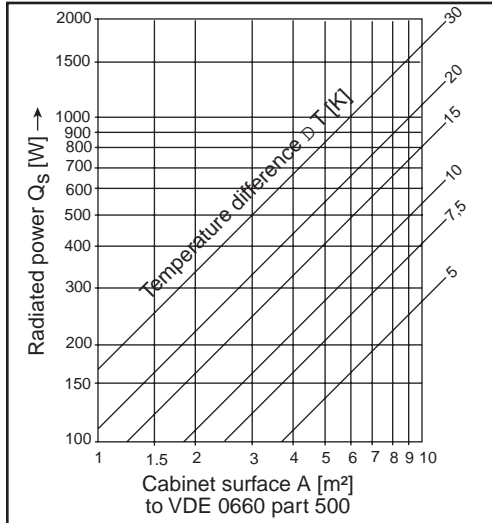


Figure 5.2 Radiated power of a switch cabinet surface

5.1.3 Calculation of filter fans

The necessary volumetric flow of a filter fan depends on the power loss of the components installed in the switch cabinet and on the difference between the maximum permissible interior and exterior temperatures:

Necessary volumetric flow

$$V = f \cdot \frac{Q_v}{T_i - T_u} \quad (2)$$

The factor f [$\text{m}^3\text{K}/\text{Wh}$] is dependent on the altitude above sea level at which the fan is operated (see Table 5.2). This takes into account the fact that the air pressure - and thus the air density - decreases as the altitude increases and the fan consequently discharges less and less heat to the outside while the volumetric flow remains constant.

Altitude above sea level [m]	f [$\text{m}^3\text{K}/\text{Wh}$]
0 - 100	3.1
100 - 250	3.2
250 - 500	3.3
500 - 750	3.4
750 - 1000	3.5

Table 5.2 Calculation factor " f " for filter fans dependent on altitude above sea level

Example: The fan is to be installed in a switch cabinet at an altitude of 80 metres above sea level, having a power loss of 600 Watts. The temperature values are $T_i = +40$ °C and $T_u = +20$ °C. Application of these values in formula (2) produces:

$$V = 3,1 \cdot \frac{600 \text{ m}^3}{20 \text{ h}}$$

Therefore a filter fan with a delivery rate of at least 93 m^3/h is required.

The filter fans should generally be selected somewhat larger than calculated, since the operational side of the filter mat becomes increasingly clogged with dirt and the heat discharge is thereby impaired. For this reason the heat emission via the switch cabinet surface should also be ignored when calculating the necessary volumetric flow of the fan.

5.1.4 Calculation of heat exchangers

In contrast to the filter fans, the heat discharge via the switch cabinet surface certainly does need to be taken into account in design of the heat exchangers. The necessary cooling power Q_E which a heat exchanger must deliver is calculated from the difference between the power loss and the radiated power of the switch cabinet.

$$Q_E = Q_V - Q_S \quad (3)$$

Example: A fully exposed sheet-steel switch cabinet is 60 cm wide, 2 m high and 50 cm deep. The power loss in the cabinet is 900 Watts.

The maximum ambient temperature is +25 °C, the temperature in the cabinet should not rise above +35 °C.

The radiated power of the switch cabinet surface is calculated according to formula (1) as:

$$Q_S = k \cdot A \cdot (T_i - T_u)$$

k designates the heat transfer coefficient and A the effective switch cabinet surface.

The heat transfer coefficient for sheet-steel is 5.5 W/m²K.

The effective cabinet surface is calculated according to DIN 57 660 Part 500 / VDE 0660 Part 500 (see Table 5.2):

$$A = 1.8 \cdot H \cdot (W + D) + 1.4 \cdot W \cdot D$$

H, W and D indicate the height, width and depth of the cabinet in meters.

Thus in our example:

$$A = (1.8 \cdot 2 \cdot (0.6+0.5) + 1.4 \cdot 0.6 \cdot 0.5) \text{ m}^2 = 4.38 \text{ m}^2$$

Applying the approximation 4.4 m² for A, formula (1) produces:

$$Q_S = k \cdot A \cdot (T_i - T_u) = 5.5 \cdot 4.4 \cdot 10 \text{ W} = 242 \text{ W}$$

Therefore the necessary cooling power of the heat exchanger according to formula (3) is:

$$Q_E = Q_V - Q_S = 900 \text{ W} - 242 \text{ W} = 658 \text{ W}$$

Then a number of other variables need to be considered, depending on whether an air-to-air or air-to-water heat exchanger is to be used.



If you want to know more about this subject, we can recommend the book entitled "Schaltschrankklimatisierung" ("Switch cabinet air conditioning" - German) published by the "Moderne Industrie" publishing company; see bibliography.

5.2 Heat transfer by conduction

When a constant flow of heat P flows through a flat wall, the temperatures ϑ_1 and ϑ_2 are produced on the two surfaces (Figure 5.3). The relationship is described in the equation

$$P = \lambda \frac{A}{d} (\vartheta_1 - \vartheta_2) \quad (1)$$

P:	Heat flow	W
λ :	Thermal conductivity	$\frac{W}{m \cdot K}$
A:	Area of wall	m ²
d:	Thickness of wall	m
ϑ_1, ϑ_2 :	Surface temperatures	°C or K

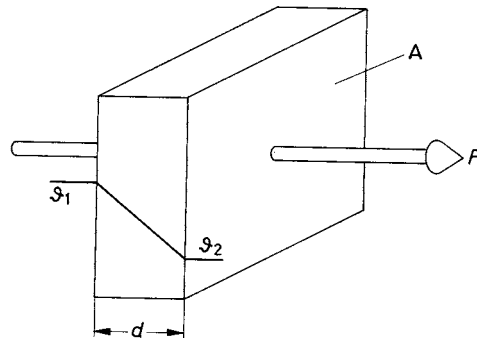


Figure 5.3 Stationary heat conduction through a wall

The thermal conductivity λ is a temperature-dependent material property. In electronic devices it can be considered as constant for most applications. Table 5.3 summarizes λ values for a number of key materials. Depending on the task at hand - provision of good heat conduction or high insulation - materials with the corresponding thermal conductivity are selected.

The thermal resistance in heat conductance, the temperature lag R_{thL} , is produced from:

$$R_{thL} = \frac{d}{\lambda \cdot A} \quad (2)$$

R_{thL} :	Temperature lag	$\frac{K}{W}$
d:	Wall thickness	m
λ :	Thermal conductivity	$\frac{W}{m \cdot K}$
A:	Wall area	m^2

Thus equation (1) can be reformulated:

$$\Delta\vartheta = \vartheta_1 - \vartheta_2 = P \cdot R_{thL}$$

If a wall comprises more than one layer, the resultant temperature lag is equal to the sum of the temperature lags of the individual layers.

Good heat conductors Material	λ
Aluminium, pure	230
Cast iron	58
V2A steel	15
Sheet-steel	59

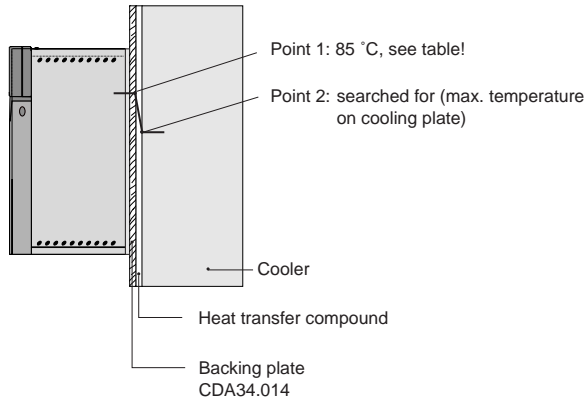
Table 5.3 Thermal conductivity of some materials at $\vartheta = 20\text{ }^\circ\text{C}$



The specific thermal contact resistance ($\gamma_{in} \frac{cm^2 \cdot K}{W}$) of metal on metal is halved when heat transfer compound is used between two metal surfaces.

5.2.1 Calculation example with CDA34.014, C (Cold Plate)

- Drive controller CDA34.014, C (size3)
- Power stage clock frequency 4 kHz



1. Power loss discharged by way of the backing plate of the drive controller.

At 4 kHz power stage clock frequency the CDA34.014 (size 3) has a power loss (see order catalogue/operation manual) of 180 W.

75 % of the power loss is discharged via the backing plate (active cooling area) and 25 % as radiated heat via the housing (Table 5.4).

$$P_{\text{Backingplate}} = 180 \text{ W} \times 0.75 = 135 \text{ W}$$

2. Calculate temperature difference between backing plate and cooling plate.

$$\Delta\vartheta = P_{\text{Backingplate}} \times R_{\text{th}}^{1)} = 135 \text{ W} \times 0.02 \text{ K/W} = 2.7 \text{ K}$$

1) see Table 5.4

3. Maximum temperature at point 2 and on the cooler

$$\vartheta_{\text{Point 2}} = \vartheta_{\text{Point 1}} - \Delta\vartheta = 85 \text{ °C} - 2.7 \text{ °C} = 82.3 \text{ °C}$$

(with 10 % safety = 78 °C)

4. Calculation of the cooler:

- At point 2 the max. temperature of 82.3 °C (78 °C) must not be exceeded.
- 135 W of power loss must be discharged by way of the cooler.
- The exact solution depends on the cooler used, e.g. heat sink to air or water, heat exchanger etc.

Project planning notes, Cold Plate - c-line DRIVES

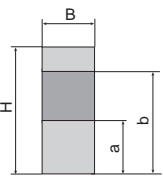
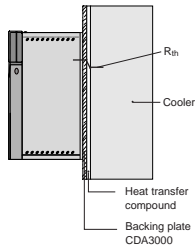
Subject	Project planning notes																																																			
Thermal connection to cooler	<ul style="list-style-type: none"> Evenness of contact surface of 0.05 mm RZR 6.3 = maximum roughness of contact surface Coat area between drive controller ("cold plate" backing plate) and cooler with heat transfer compound (coat thickness 30-70µ). The temperature in the middle of the drive controller backing plate must not exceed 85 °C. 																																																			
Distribution of power loss	<table border="1" style="width: 100%; border-collapse: collapse;"> <thead> <tr> <th>Size</th> <th>Power</th> <th>Heat sink</th> <th>Housing</th> </tr> </thead> <tbody> <tr> <td>Size 1/2</td> <td>0.37 to 2.2 kW</td> <td>approx. 65 %</td> <td>approx. 35 %</td> </tr> <tr> <td>Size 3</td> <td>3 to 4 kW</td> <td>approx. 70 %</td> <td>approx. 30 %</td> </tr> <tr> <td>Size 4</td> <td>5.5 to 7.5 kW</td> <td>approx. 75 %</td> <td>approx. 25 %</td> </tr> <tr> <td>Size 5</td> <td>11 to 15 kW</td> <td>approx. 80 %</td> <td>approx. 20 %</td> </tr> <tr> <td>Size 6¹⁾</td> <td>22 to 37 kW</td> <td>approx. 85 %</td> <td>approx. 15 %</td> </tr> </tbody> </table>						Size	Power	Heat sink	Housing	Size 1/2	0.37 to 2.2 kW	approx. 65 %	approx. 35 %	Size 3	3 to 4 kW	approx. 70 %	approx. 30 %	Size 4	5.5 to 7.5 kW	approx. 75 %	approx. 25 %	Size 5	11 to 15 kW	approx. 80 %	approx. 20 %	Size 6 ¹⁾	22 to 37 kW	approx. 85 %	approx. 15 %																						
Size	Power	Heat sink	Housing																																																	
Size 1/2	0.37 to 2.2 kW	approx. 65 %	approx. 35 %																																																	
Size 3	3 to 4 kW	approx. 70 %	approx. 30 %																																																	
Size 4	5.5 to 7.5 kW	approx. 75 %	approx. 25 %																																																	
Size 5	11 to 15 kW	approx. 80 %	approx. 20 %																																																	
Size 6 ¹⁾	22 to 37 kW	approx. 85 %	approx. 15 %																																																	
Active cooling area	<div style="display: flex; align-items: center;">  <table border="1" style="margin-left: 20px; border-collapse: collapse;"> <thead> <tr> <th rowspan="2">Size</th> <th rowspan="2">Power [kW]</th> <th colspan="2">Device basic area [mm]</th> <th colspan="2">Active cooling area [mm]</th> </tr> <tr> <th>B</th> <th>H</th> <th>a</th> <th>b</th> </tr> </thead> <tbody> <tr> <td>Size 1</td> <td>0.37 to 0.75 kW</td> <td>70</td> <td>193</td> <td>50</td> <td>165</td> </tr> <tr> <td>Size 2</td> <td>1.1 to 2.2 kW</td> <td>70</td> <td>218</td> <td>90</td> <td>200</td> </tr> <tr> <td>Size 3</td> <td>3 to 4 kW</td> <td>100</td> <td>303</td> <td>120</td> <td>260</td> </tr> <tr> <td>Size 4</td> <td>5.5 to 7.5 kW</td> <td>150</td> <td>303</td> <td>65</td> <td>215</td> </tr> <tr> <td>Size 5</td> <td>11 to 15 kW</td> <td>200</td> <td>303</td> <td>80</td> <td>300</td> </tr> <tr> <td>Size 6¹⁾</td> <td>22 to 37 kW</td> <td>190</td> <td>405</td> <td>190</td> <td>345</td> </tr> </tbody> </table> </div>						Size	Power [kW]	Device basic area [mm]		Active cooling area [mm]		B	H	a	b	Size 1	0.37 to 0.75 kW	70	193	50	165	Size 2	1.1 to 2.2 kW	70	218	90	200	Size 3	3 to 4 kW	100	303	120	260	Size 4	5.5 to 7.5 kW	150	303	65	215	Size 5	11 to 15 kW	200	303	80	300	Size 6 ¹⁾	22 to 37 kW	190	405	190	345
Size	Power [kW]	Device basic area [mm]		Active cooling area [mm]																																																
		B	H	a	b																																															
Size 1	0.37 to 0.75 kW	70	193	50	165																																															
Size 2	1.1 to 2.2 kW	70	218	90	200																																															
Size 3	3 to 4 kW	100	303	120	260																																															
Size 4	5.5 to 7.5 kW	150	303	65	215																																															
Size 5	11 to 15 kW	200	303	80	300																																															
Size 6 ¹⁾	22 to 37 kW	190	405	190	345																																															
Thermal resistance	<div style="display: flex; align-items: center;">  <table border="1" style="margin-left: 20px; border-collapse: collapse;"> <thead> <tr> <th>Size</th> <th>Power [kW]</th> <th>Temperature lag between active cooling area and cooler R_{th} [K/W]</th> </tr> </thead> <tbody> <tr> <td>Size 1</td> <td>0.37 to 0.75 kW</td> <td>0.05</td> </tr> <tr> <td>Size 2</td> <td>1.1 to 2.2 kW</td> <td>0.05</td> </tr> <tr> <td>Size 3</td> <td>3 to 4 kW</td> <td>0.03</td> </tr> <tr> <td>Size 4</td> <td>5.5 to 7.5 kW</td> <td>0.02</td> </tr> <tr> <td>Size 5</td> <td>11 to 15 kW</td> <td>0.015</td> </tr> <tr> <td>Size 6¹⁾</td> <td>22 to 37 kW</td> <td>0.01</td> </tr> </tbody> </table> </div>						Size	Power [kW]	Temperature lag between active cooling area and cooler R _{th} [K/W]	Size 1	0.37 to 0.75 kW	0.05	Size 2	1.1 to 2.2 kW	0.05	Size 3	3 to 4 kW	0.03	Size 4	5.5 to 7.5 kW	0.02	Size 5	11 to 15 kW	0.015	Size 6 ¹⁾	22 to 37 kW	0.01																									
Size	Power [kW]	Temperature lag between active cooling area and cooler R _{th} [K/W]																																																		
Size 1	0.37 to 0.75 kW	0.05																																																		
Size 2	1.1 to 2.2 kW	0.05																																																		
Size 3	3 to 4 kW	0.03																																																		
Size 4	5.5 to 7.5 kW	0.02																																																		
Size 5	11 to 15 kW	0.015																																																		
Size 6 ¹⁾	22 to 37 kW	0.01																																																		
1) Only CDE/CDB3000																																																				

Table 5.4 Project planning notes, "Cold plate"

Simulation result with Rittal liquid cooler DCP:

Two 22 kW drive controllers with a power loss of 1300 W were mounted on the liquid cooler.

$T_u = 40\text{ °C}$ (cabinet ambient temperature), $T_i=55\text{ °C}$ (cabinet interior temperature), coolant inlet 25 °C .

Initial complex simulations show that the maximum surface temperature of the cold plate does not exceed 35 °C .

Increasing service life of power electronics with Cold Plate Temperature $<35\text{ °C}$.

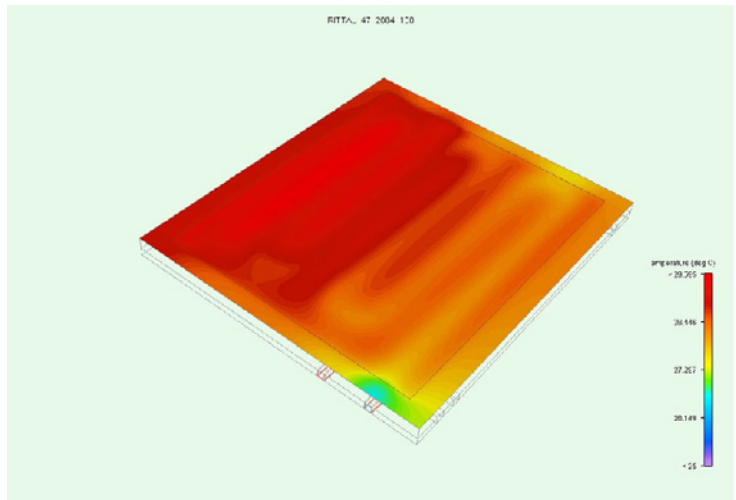


Figure 5.4 Simulation of temperature curve



Practical heating tests with positioning drive CDE/CDB34.070 on a DCP test installation were performed. We will be pleased to provide you with the results.



Figure 5.5 Mounting example with CDA3000 and braking resistor on liquid-cooled component backing plate



For more information on a system solution with optimum cooling with DCP (Direct Cooling Package) contact:
Rittal GmbH, 35726 Herborn, Gemany (www.rittal.de).

Special design CDE/CDB3000 (22 to 37 kW) with liquid heat sink

No further project planning information was available at the time of going to press.

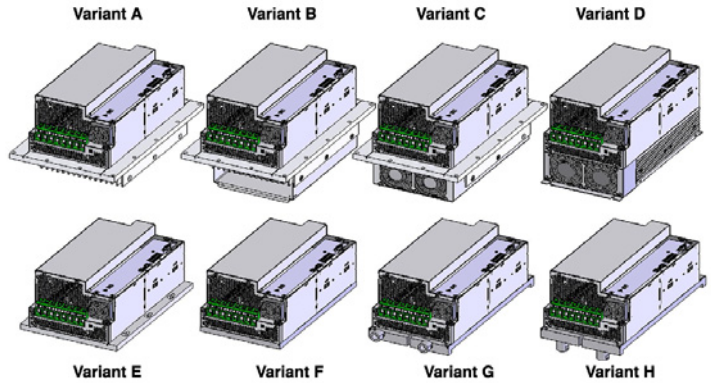


Figure 5.6 Possible heat sink variants for CDE/CDB3000 size 6

Variant A	Push-through heat sink 1	Variant E	Cold Plate heat sink 1
Variant B	Push-through heat sink 2	Variant F	Cold Plate heat sink 2
Variant C	Push-through heat sink 3	Variant G	Liquid heat sink 1
Variant D	Wall mounting	Variant H	Liquid heat sink 2

5.3 System feedback of power drives

The input currents of drive controllers, positioning drives and servocontrollers are not sinusoidal, because of the uncontrolled diode bridge used. The various influences on the electric power system and on the system's voltage quality are grouped under the umbrella term "system feedback". The standards relating to system feedback are generally linked to the range of EMC standards. The key terms are explained in the following.

The key modes of system feedback of power drive controllers with an uncontrolled diode bridge are:

- Current harmonic content
- Voltage dips



Standards reference for drive systems (PDS's)¹⁾ deployed in industrial environments (2nd environment).

Product norm	Basic norm	Testing
EN 61800-3 5.2.1 Table 2	IEC 61000-2-4 Criterion A IEC 60146-1-1 Criterion A	THD and individual order or harmonics THD ²⁾ = 10 % (class 3) Commutation notches depth = 40 %, total area = 250 % x degrees
$^2) \text{ THD} = \sqrt{U_5^2 + U_7^2 \dots U_{41}^2} \quad U_n \text{ as \% of } U_{\text{Fundamental}}$		

Determining the THD and the commutation notches depends on the system conditions and is possible only by on-site measurement.

1)Power DRIVE Systems,
2)Total Harmonic Distortion

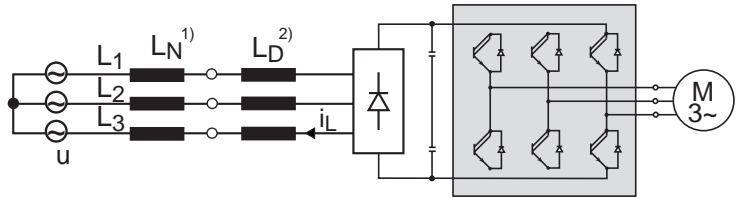
Current harmonic content

The periodic, non-sinusoidal characteristic of a mains current can be arithmetically split by Fourier analysis into sinusoidal current components with different frequencies.

$$n = k \cdot p_z \pm 1 \quad (1)$$

n Harmonic number
 p_z Number of pulses
 k 1, 2, 3 ...

The equation (1) demonstrates that in a 2-pulse bridging circuit (1-phase controllers) harmonic numbers 3, 5, 7, 9 ... occur, and in a 6-pulse bridging circuit (3-phase controllers) harmonic numbers 5, 7, 11, 13



- 1) Line impedance
- 2) Line choke

Figure 5.7 Block diagram

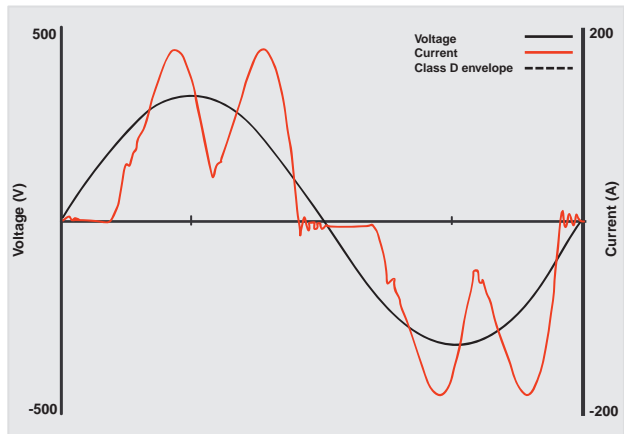


Figure 5.8 Typical current curve (*i_L*) with controlled B6 diode bridge

What is so unpleasant about harmonic currents?

The currents generate harmonic voltages on the system reactances which cause the voltage quality to deteriorate.

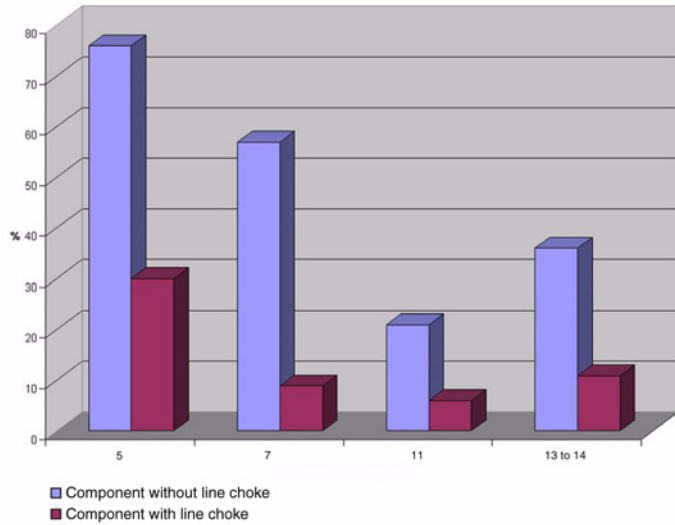


Figure 5.9 Total harmonic distortion based on the example of a 4 kW drive controller/servocontroller

Voltage dips

Voltage dips occur during so-called commutation¹⁾ of the current in the input rectifier of the drive controller. The level of the voltage dips or commutation notches depends on the ratio of the reactance of the line choke to the reactance of the system.

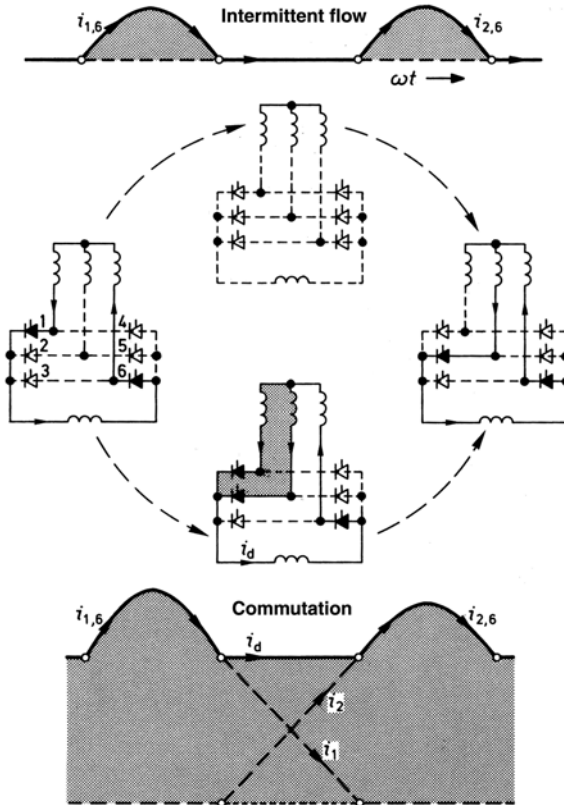


Figure 5.10 Example of a three-phase bridge. Time range: 1/3 of period



By using line chokes with 4 % short-circuit voltage the commutation notches can be reduced by as much as 70 %.

1) Carrying forward of the current from one bridge section to the other

5.3.1 Reducing system feedback

In summary:

Drive controllers, positioning drives and servocontrollers have uncontrolled input rectifiers (diode bridge B6, B2) in the mains input to generate the constant DC-link voltage. The DC-link capacitors of the drive controllers are recharged at the maximum mains voltage. Depending on the internal resistance (impedance) of the supply system, without line chokes high non-sinusoidal charging current peaks would occur, which would place a strain not only on the system but also on the DC-link capacitors of the drive units.

By using a line choke with $U_k = 4\%$ (short-circuit voltage) the current flow time is extended and the amplitude of the system charging current is greatly reduced. The system loads are additionally reduced by more than half by harmonics and commutation notches.

The level of the charging currents occurring is determined by the drive controller power output and, fundamentally, by the line impedance. As the line impedance decisively determines the occurring charging currents, you need to concern yourself with the following questions:

- What is the impedance of your system?
- What is the ratio at present of the short-circuit power to the drive controller power?
- Does the line impedance change over time?
- Are conductor routings changed, and what effect do the changes have?
- Are supply transformers switched in parallel?
- Is emergency power mode provided?
- At which system connection point will drive controller or servo systems be installed in future?
- Will the system's environment class change in future, e.g. due to installation of a spot-welding machine?

What does that mean for you? As it is likely that no one can answer these questions for you, you can only be reasonably sure of avoiding problems by using line chokes. Because the line choke isolates your drive unit from the system and protects it against excessively high charging peaks and system voltage asymmetries, see section 4.1.



Increasing short-circuit power:

Another means of reducing system feedback (harmonics, voltage asymmetry) is to connect the drive controller drive to a supply transformer with a high short-circuit power. This measure reduces the impedance of the supplying system, causing the voltage dips in the system due to the harmonic content of the drive controller current also to decrease.

- **Use of passive or active harmonic filter modules**

Filters of this kind reduce the total harmonic distortion to THD-I¹⁾ $\leq 16\%$ or $\leq 10\%$

Procedure in practice

In order to establish whether your application conforms to the EN 61800-3/IEC1800-3 standard or another standard, you must ascertain the equivalent drive controller referred to your line transformer. Based on the equivalent drive controller and the line impedance, you then calculate the voltage distortion THD. You need to weight the result relative to the overall system ratios.

Theoretical calculation of the system ratios can only serve as a guide. If the theoretical calculation reveals that you are at the limits specified in the standards, you should always carry out a system analysis by means of systems analysts (measurement duration typically seven days). Only in this way is a practice-oriented assessment of your power supply system possible, enabling the above-mentioned "representative questions" to be answered.

EN 61800-3/IEC1800

1)THD-I (Total Harmonic Distortion-Current)

5.4 Reactive current compensation systems in electric power systems with non-linear loads



Electrical devices¹⁾ and machines¹⁾ subject the public electricity supply systems to load not only based on their effective power consumption but also by their consumption of reactive power. The transmission of reactive power to the consumer causes additional losses in the system. In order to minimize these losses and keep the reactive power consumption down, so-called reactive current compensation systems are installed.

The erectors and operators of reactive current compensation systems must increasingly confront the question of resonance from capacitors, harmonics and choking. The following largely generalized comments are intended to provide an overview of the subject, set in the context of power drive systems.

Netzrückwirkungen [System feedback]

Hormann/Just/Schlabbach

Anlagentechnik für elektrische Verteilungsnetze

[System engineering for electrical distribution systems] (vol. 14)

Rolf R. Cichowski (publ.)

VDE-Verlag, ISBN 3-8022-2231-3

Versions of reactive current compensation systems

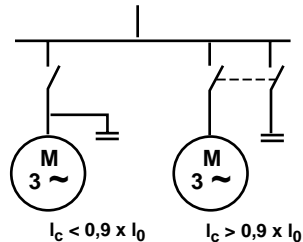


Figure 5.11 Simplified view of a single compensation

1) Power converters, UPS systems, arc furnaces, smelting furnaces, drive controllers, servocontrollers, welding machines, presses, punches, energy-saving bulbs, motors ...

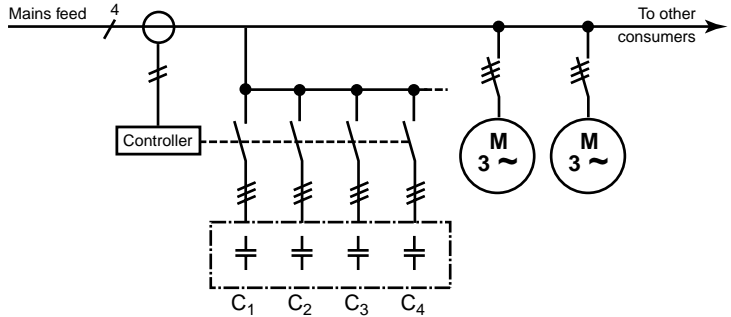


Figure 5.12 Simplified view of the automatically controlled central compensation system

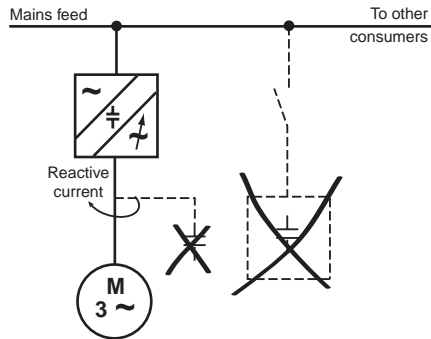


Figure 5.13 Simplified view of the situation in drive controller operation



Reactive current compensation systems in drive controller operation: For all motors operated on a voltage DC-link drive controller (servo-controller, drive controller or positioning drive) no reactive current compensation need be performed. The drive controller is a source of system load with virtually $\cos \varphi \approx 1$.

5.4.1 Resonance frequency in electric power systems

Resonance frequencies in electric power systems result primarily from the interaction of line impedance, the compensation system and consumer impedances. For a rough calculation of the resonance frequency it is sufficient to take account only of the reactances of the mains transformer and the reactive current compensation.

$$f_{\text{res}} \approx f_1 \sqrt{\frac{S_K''}{Q_C}} \approx f_1 \sqrt{\frac{S_T \cdot 100}{U_K \cdot Q_C}}$$

SK'' = System short-circuit power with mains voltage at connection point

For S_T the rated apparent power of the mains transformer should be used; for U_K is short-circuit voltage in %; for Q_C the compensation of the reactive current compensation system; and for f_1 the mains frequency. According to the formula, it is demonstrated that the resonance frequency steadily decreases as the compensation increases, and so comes close to the harmonics generated by the drive controller, e.g. 250 Hz [(5th harmonic), 350 Hz (7th harmonic)]. This in turn can cause the harmonics to be drawn off by the capacitors of the reactive current compensation system, causing them to overload.

What to do if the resonance frequency is of an order of 5, 7 or 11 corresponding to the frequencies 250 Hz, 350 Hz or 550 Hz?

The risk of resonance can be avoided by expanding capacitors to form series resonant circuits by interposing chokes. They are usually tuned such that the resonance frequency is below the lowest harmonic frequency, e.g. 250 Hz.

In practice the so-called choking factor is specified for choked compensation systems. The following table sets out the choking factors primarily used and the associated resonance frequencies.

Choking factor	Resonance frequency
5.67 %	210 Hz
7 %	189 Hz
14 %	134 Hz

Table 5.5 Choking factors



As the choking factor increases so does the voltage at the capacitors, necessitating the use of capacitors with higher mains voltage.

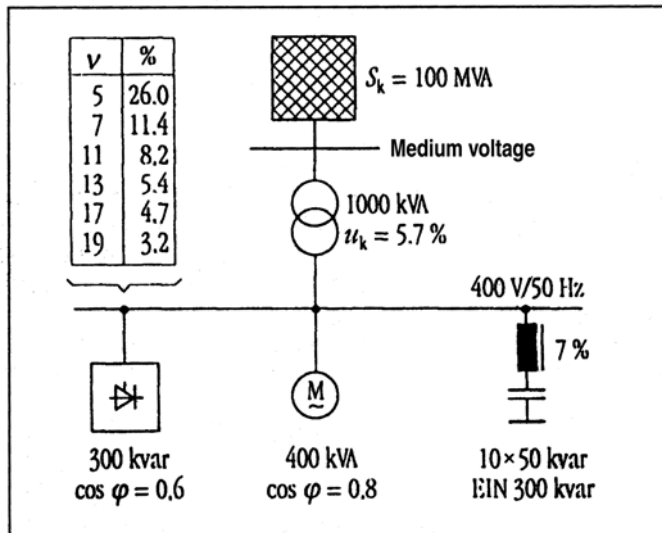


Figure 5.14 Compensation with harmonic generator and 7 % choking

In summary

Calculation of the resonance frequency serves as an estimate under ideal system conditions.

In designing reactive current compensation systems the full mix of all the consumers in the system must be analyzed. The correlations between them must also be analyzed in times of weak load, as shifts may occur at those times especially which would contribute to faster generation of resonance.

Please note that this section aims merely to provide a rough overview of the correlation between capacitors and harmonics. When planning an electric power system or reactive current compensation system always consult a specialist company.



Practical tip from reactive current compensation system manufacturer:

If the ratio of harmonics-generating devices/machines in kW to the overall power output of the plant exceeds 15 %, choked reactive current compensation systems should always be installed.

5.5 Electromagnetic compatibility (EMC) and power drives

General legal grounds

After the European Commission had established a European regulation in the form of the EMC Directive, the demand for EMC standards increased. European standards are drawn up by the European standardization organization CENELEC, within which the TC 110 group deals with matters relating to EMC.

The standards structure comprises:

- the basic norm
- generic norms
- product norms

The generic norms covering interference emission and interference immunity lay down the requirements made of the equipment according to the ambient conditions in which it is operated.

The standards covering specific products or product families (product norms) **have priority** over the generic norms however.

EN 50081-1/-2 and EN 50082-1/-2 are generic norms. EN 61800-3 is an EMC product norm for power drives, and so has priority over EN 50081/82

5.5.1 EMC standardization of power drives

The EMC standard applicable to power drives is EN 61800-3. It in turn makes reference to various basic norms stipulating measurement methods.

The EMC product norm EN 61800-3 has priority over all the requirements set out in the generic norms EN 50081-1/-2 and EN 50082-1/-2. It covers all the necessary testing. Only if a power drive is installed in another unit for which a specific EMC product norm exists is the EMC product norm for that unit applicable.

The power range of a drive system extends from <100 W for connection to low-voltage systems and from 230 V to >1 MW for connection to medium-voltage systems. This wide range cannot be covered by the generic norms alone.

Consequently, the generic norms covering interference immunity also exist, stipulating the requirements for the external ports, and mostly only units with $I_{\leq} 16$ A. The generic norms covering interference emission in turn stipulate only measurements for devices for connection to low-voltage systems.

For measurements on a measuring station often only system simulations in the current range from 16 A to 100 A are available. These restrictions were the reason for drafting an EMC product norm for variable-speed power drives, based on which all drive systems can be assessed in accordance with the requirements of the EMC Directive.

EMC product norm for variable-speed power drives

EN 61800-3:2004 Variable-speed power drives, part 3: EMC product norm including specific test methods. The transitional period for the former EN 61800-3:1996 ends on 1st October 2007.

EN 61800-3 covers the power drive system from the mains connection through to the motor shaft output, defines various categories C1 to C4, different environments (residential/industrial), external ports and internal interfaces. It sets out assessment criteria for operational response to interference at the external ports and the internal interfaces, and contains requirements relating to interference immunity according to the ambient conditions at the place of use.



Definition of terms

First environment (residential and commercial): Environment containing residential areas and also facilities connected directly to a low-voltage system supplying the residential building with no interposed transformer.

Second environment (industrial): Facilities not connected directly to a low-voltage system supplying residential areas.

Private system

The private system is characterized in that it is supplied by a dedicated transformer station from the medium-voltage system and supplies small residential areas. The private system typically supplies administrative buildings, high-rise office blocks, shopping centres etc. It is left to the discretion of the operators as to whether they execute the system as a first or second environment under the terms of the norm.

In compliance with the EMC Act, a private low-voltage system can be classified as an installation. The EMC is assessed at the physical boundary of the installation; outward and inward emissions are assessed at the physical boundary; line-borne phenomena are assessed at the mains feed point (medium- or high-voltage connection).

PDS of category C1

PDS with a rated voltage <1000 V for use in the first environment.

PDS of category C2

PDS for use in the first environment, meeting all the following criteria:

- Rated voltage < 1000 V
- Not connected by plug-and-socket devices
- Not mobile
- Connection and commissioning only by technical EMC specialist.
- Warning notice required

Warning notice in documentation:

This is a product of category C2 to IEC 61800-3. In a residential environment this product may cause high-frequency interference, in case of which interference suppression measures may be necessary.

PDS of category C3

PDS with a rated voltage <1000V, for use in the second environment. No use in the first environment is allowed.

Warning notice in documentation:

"This PDS is not intended for connection to the public system. If connected to those systems, electromagnetic interference may occur".

PDS of category C4

PDS for connection in the second environment, meeting at least one of the following criteria:

- Rated voltage > 1000 V
- Rated current > 400 A
- Connection to IT systems
- Required dynamic properties are not attained owing to the EMC filter measures

An EMC plan must be drawn up!

Requirements of EN 61800-3 relating to interference immunity according to the ambient conditions at the place of use
In the low-frequency range (< 9 kHz)

- Against harmonics as per IEC 61000-2-2 /-4
- Against commutation notches in the mains voltage as per IEC 60146-1-1
- Against voltage changes, fluctuations, dips and interruptions as per IEC 61000-2-2-2
- Against voltage asymmetries and frequency changes as per IEC 61000-2-2 /-4

In the high-frequency range (> 9 kHz)

- Against electrostatic discharge (ESD) as per IEC 61000-4-2
- Against high-frequency electromagnetic fields as per IEC 61000-4-3
- Against burst voltages as per IEC 61000-4-4
- Against surge voltages as per IEC 61000-4-5
- Against line-borne interference induced by high-frequency fields as per IEC 61000-4-6

Requirements of EN 61800-3 relating to interference emission according to the ambient conditions at the place of use
In the low-frequency range (< 9 kHz)

- Of harmonics as per IEN 61000-3-2/-12
- Of voltage fluctuations/flicker as per IEG 61000-3-3/-11
- Of mains voltage commutation notches as per IEG 60146-1-1



Note:

Second environment

Here operators may implement centralized measures to reduce interference emissions. The interference emissions of the individual devices can be defined in consultation.

In the high-frequency range (> 9 kHz)

- Of interference voltage as per EN 61800-3
- Of interference radiation as per EN 61800-3

First environment

Category C1	Category C2
Limits of EN 61800-3 match EN 55011 class B	Limits of EN 61800-3 match EN 55011 class A group 1

Second environment

Category C3	Category C4
Limits of EN 61800-3 match EN 55011 class A group 2	Interference emissions exceed the limits of EN 55011 class A group 2

Planning and execution

Alongside the functional tasks of a component, machine or system, the EMC measures to be taken should be incorporated right from the planning phase. Only at that stage is it possible to cover EMC requirements in a cost-effective manner. In the test phase, or even in operation, the possible measures are dramatically reduced and the costs rise.

Ultimate responsibility for compliance with the EMC Act lies with the entity which "bring into circulation" a machine or system.

It is therefore important that the manufacturer/erector of a machine or system ensures even when purchasing its components that EMC requirements are covered and specifications are issued as to how conformity to the EMC Directive is to be attained.

Of decisive importance with regard to variable-speed drives is the standard EN 61800-3 listed under the EMC Directive. As an EMC product norm, it has priority over the generic norms. EN 61800-3 does not view the individual component (drive controller, motor ...), but sees the so-called Power Drive System (PDS) as a whole, including all components from the feed through to the motor. Thus a declaration of conformity is given relating to a complete system, not to an individual component.

Components are usually only sold to professional specialists, and are intended for professional use. CE marking of these components in most cases relates merely to the Low-Voltage Directive, but not to the EMC Directive. Its requirements are to be met by consideration of the area of use, by correct and proper set-up, and - as appropriate - by the use of additional interference suppression measures (filters etc.). In this, the user relies on information given in the component manufacturer's documentation.

This may include, for example:

- the method of cable laying,
- constructional screening measures,
- the type and maximum length of the motor cable,
- filters to be used.

Areas of use

Responsibility for the electromagnetic compatibility of a device, system or item of plant differs depending on the distribution channel, method of marketing and area of use. Ultimately, the easiest way to achieve an EMC-conforming end product is to establish good lines of cooperation throughout the value-adding chain.

The following examples are intended to provide an overview of the issue of EMC, which appears complicated only at first glance.

First environment (residential and commercial)

Power Drive Systems (PDS's) are usually not deployed as stand-alone items of equipment in private households. They form part of equipment such as domestic appliances, power tools, air-conditioning units, etc.

Responsibility for the electromagnetic compatibility of these kinds of applications lies with the appliance/unit manufacturer. If PDS's are included in installations such as lifts, heating systems or air-conditioning units, responsibility for electromagnetic compatibility lies with the installers/erectors. They should take into consideration the EMC-related product characteristics and the installation rules of the component manufacturers right from the planning phase.

Second environment (industrial)

The electromagnetic compatibility of one or more PDS's in an industrial system can normally be safeguarded right from the planning phase by complying with the relevant norms and limits. To this end, in the low-frequency range the expected interference emissions, their effects in the supply system and those of the further compensation measures are calculated.

At higher frequencies, quantitative forecasts on the one hand become increasingly less reliable (due to unknown influences such as of parasitic capacitances and inductances) and on the other hand also become less important, because in industrial systems experience shows that interference seldom occurs at high frequencies (e.g. radio frequency interference). Problems can usually be avoided by

- following the manufacturers' installation instructions,
- laying signal and power cables separately,
- not operating sensitive equipment in the immediate vicinity of high-power drives and operating them on a separate system,
- and equipping the drives with special HF filters and screened cables as necessary.

For EMC planning in the industrial sector it must especially be ensured that plans incorporate requirements relating to the point of connection to the public system operated by the local utility company and that increased demands within the industrial system, such as those going beyond standardized limits, are agreed between the manufacturer and user.

Line-borne feedback in the low-frequency range is of key importance in industrial systems:

- Periodic voltage dips due to commutation within the power converters,
- voltage distortions from superimposed harmonic currents,
- voltage fluctuations resulting from rapid load changes (especially reactive power. Load changes are usually stipulated by the process).

Technology offers a range of possibilities for keeping this feedback within bounds and safeguarding electromagnetic compatibility.

1

2

3

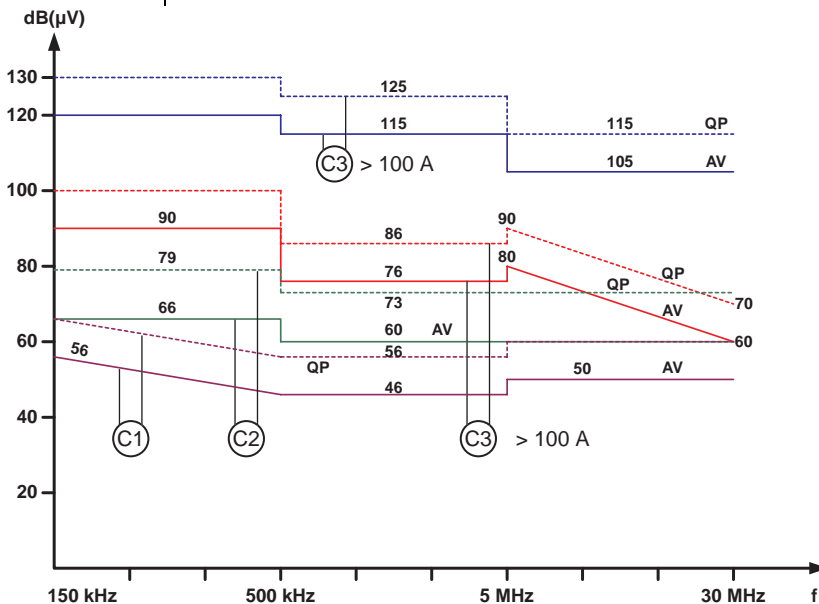
4

5

6

A

5.5.2 Limit curve for power drives (PDS's)



First environment

Category C1	Category C2
Limits of EN 61800-3 match EN 55011 class B	Limits of EN 61800-3 match EN 55011 class A group 1

Second environment

Category C3	Category C4
Limits of EN 61800-3 match EN 55011 class A group 2	Interference emissions exceed the limits of EN 55011 class A group 2
EN 61800-3 defines measurement methods and limits at the boundaries to systems supplied by a different medium-voltage transformer as per EN 55011 class B or class A group 1.	

5.5.3 Typical measurement set-up for acceptance testing of power drives

To verify compliance with the EMC norms stipulated by law, alongside the internal measurements a check is also carried out at an external "accredited EMC test laboratory".

To provide you with an idea of the measurements and measurement set-up required by law, we have in the following set out a number of tables and illustrations taken from test report P030947 from the Mectronic corporation.

The tables and illustrations relate to the positioning drive for asynchronous motors type: CDB34.032, W1.0, BR (15 kW, 400 V).

Table of tests carried out

Minimum interference immunity requirements for PDS's intended for use in industrial environments (2nd environment)

Reference norm	Testing	Basic norm	Carried out	Met
EN 61800-3, Tab.6 Enclosure	Electrostatic discharge (ESD) ±6 kV contact discharge or alternatively ±8 kV discharge to air (if contact discharge not possible)	EN 61000-4-2 Criterion B	Yes	Yes
	Electromagnetic fields 10 V/m, 80-1000 MHz, 80 % AM/1 kHz	EN 61000-4-3 Criterion A	Yes	Yes
Power connection	Burst ±2 kV, asym., 5/50ns tr/th, trep	EN 61000-4-4 Criterion B	Yes	Yes
	HF induced on lines 10 V, 0.15-80 MHz, 80 % AM / 1 kHz (CDN coupling network)	EN 61000-4-6 Criterion A	Yes	Yes
	Surge ±1 kV sym., ±2 kV asym., 1.2/50 µs	EN 61000-4-5 Criterion B	Yes	Yes
Power interfaces	Burst ±2 kV, asym., 5/50ns tr/th, trep 5 kHz (with burst coupling clamp)	EN 61000-4-4 Criterion B	Yes	Yes
Signal interfaces	Burst ±2 kV, asym., 5/50ns tr/th, trep 5 kHz (with burst coupling clamp)	EN 61000-4-4 Criterion B	Yes	Yes
	HF induced on lines 10 V, 0.15-80 MHz, 80 % AM/1 kHz (CDN coupling clamp)	EN 61000-4-6 Criterion A	Yes	Yes
Connection for process-oriented instrumentation and control functions	Burst ±2 kV, asym., 5/50ns tr/th, trep 5 kHz (with burst coupling clamp)	EN 61000-4-4 Criterion B	Yes	Yes
	HF induced on lines 10 V, 0.15-80 MHz, 80 % AM/1 kHz (CDN coupling clamp)	EN 61000-4-6 Criterion A	Yes	Yes

Table 5.6 Interference immunity

Interference emission requirements for PDS's with restricted availability, intended for use in industrial systems (2nd environment).

Reference norm	Testing	Basic norm	Carried out	Met
EN 61800-3 6.3.1.1, Tab.11	RFI suppression 0.15 ... 30 MHz	CISPR 11 Class A	Yes	Yes
EN 61800-3 6.3.1.2, Tab.12	RFI suppression 30 ... 1000 MHz	CISPR 11 Class A	Yes	Yes

Table 5.7 interference emission

Test aids used

Identification	Designation	Type	Manufacturer
Q009150	RFI measurement receiver (9 kHz ... 30 MHz)	ESHS10	Rohde & Schwarz
Q018552	RFI measurement receiver (20 kHz ... 1000 MHz)	ESVS10	Rohde & Schwarz
Q009506	Free field measuring station	CSD	X measuring systems
Q020930	Hybrid antenna (30 ... 1000 MHz)	BTA-L	Frankonia
Q010892	Field strength meter	PMM 8051	Isotropic
Q010893	I/O converter	OR-1 PMM 8051	Isotropic
Q020998	HF probe	BA 01	Isotropic
Q006012	V artificial mains network 3ph	ESH2-Z5	Rohde & Schwarz
Q009896	Pulse limiter	HZ 560	Hameg
Q019631	Signal generator	PSG 1000B	Farnell
Q025191	Signal generator	HP 8657 B	Hewlett Packard
Q018112	Power amplifier	3100 LA	ENI
Q009387	Power amplifier	30W1000M7	Amplifier Research
Q019630	Power amplifier	75 A 220	Amplifier Research
Q020713	Millivoltmeter	URV 55	Rohde & Schwarz
Q018060	ESD test gun	NSG 435	Schaffner
Q006038	Interference simulator	NSG 600	Schaffner
Q006036	Burst generator plug-in	NSG 625	Schaffner

Table 5.8 Test aids used

Identification	Designation	Type	Manufacturer
Q030065	Surge generator	UCS500	EM Test
Q009397	Coupling network	CCN 2000	Schaffner
Q006030	Capacitive coupling clamp	SL400-071	Schaffner
Q017110	HF coupling clamp	EM 101	Lüthi
Q020742	Coupling network	CDN M5 32A	Fiedler

Table 5.8 Test aids used

Photos of the test set-ups

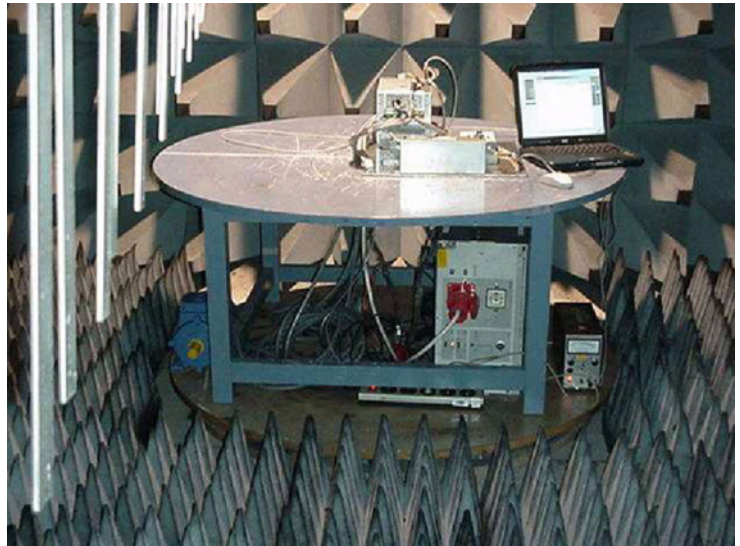


Figure 5.15 RFI voltage and RFI field strength (base without absorber), HF irradiation

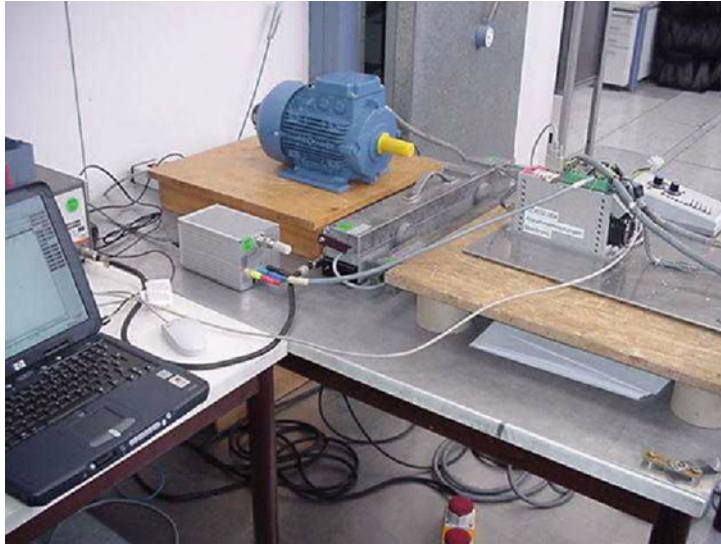


Figure 5.16 HF injection on lines (picture taken from test report P030941)

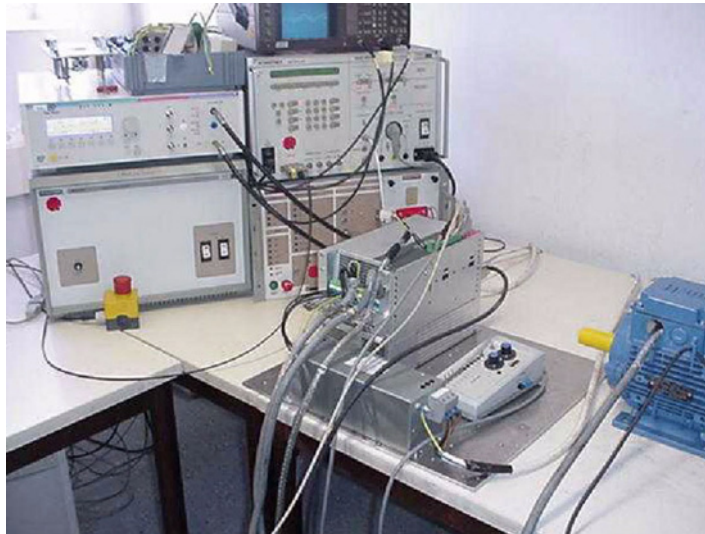


Figure 5.17 Burst and surge on mains line

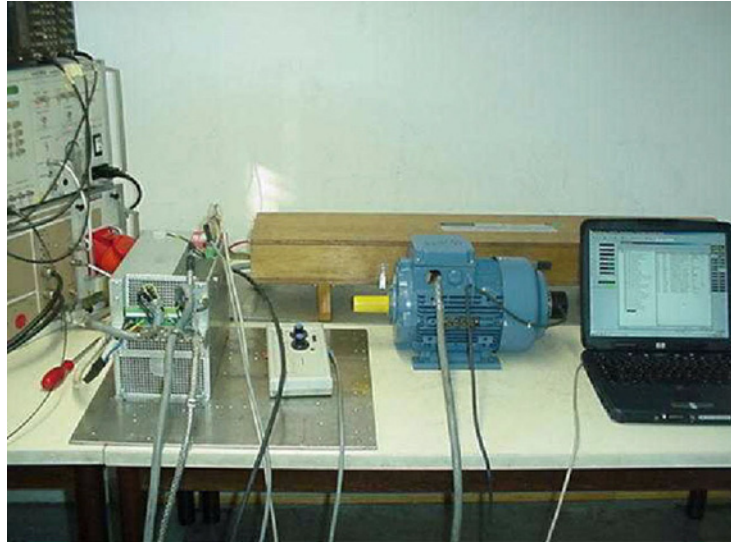


Figure 5.18 Burst on signal and data lines



Figure 5.19 Electrostatic discharge (ESD), contact discharge



Figure 5.20 Free field measurement of RFI field strength

5.5.4 Installation guidelines for switch cabinets

To safeguard electromagnetic compatibility in switch cabinets and comply with the protection goals and norms stipulated by law, the following installation guidelines must be followed.

Subject	Projecting planning and installation rules
PE conductor connection Equipotential bonding	<p>Use a metallicly bright backing plate. Use as large as possible cable cross-sections and/or earthing straps. Make PE connection of components in star configuration. To establish the low-resistance HF connection the earth (PE) and the screen connection must be applied onto the PE rail of the backing plate across a wide area. PE mains connection to DIN VDE 0100 part 540</p> <ul style="list-style-type: none"> • Mains connection < 10 mm²: Use PE conductor cross-section min. 10 mm² or two cables with cross-section of mains cables. • Mains connection > 10 mm²: Use PE conductor cross-section according to cross-section of mains cables.
Cable routing	<ul style="list-style-type: none"> • Lay motor cable separate from signal cables and mains cable. Minimum distance between motor cable and signal/ mains cable must be 20 cm, use a separator as necessary. • Route motor cable without breaks always along the shortest path out of the cabinet. • If a motor contactor or motor choke/filter is used, it should be placed directly on the drive controller. Do not strip motor cable screen too early. • Avoid unnecessary cable lengths.
Cable type	<p>The drive controllers should always be wired with screened motor and signal cables. For all screened connections a cable type with double copper braiding with 60-70 % coverage must be used.</p>
More tips for cabinet design	<ul style="list-style-type: none"> • Contactors, relays, solenoids (switched inductors) should be wired with fuses. They must be wired directly on the respective coils. • Switched inductors should be at least 20 cm away from process-controlled modules. • Place larger consumers close to the in-feed. • Where possible introduce signal cables only from one side. • Cables on the same circuit should be twisted together. As a general rule cross-talk is reduced if cables are laid close to earthed panels. Connect residual cores at both ends to cabinet earth.
Supplementary information	<p>For supplementary information refer to the relevant connection specification.</p>

Table 5.9 Projecting planning and installation rules

- As the components in the cabinet are not only drive controllers, but also controls, switched-mode power supply units, regulators and sensors with wide ranges of interference emission and interference immunity, it is not practicable to establish a single, universal set of **installation guidelines**.
- Installation guidelines are recommendations from the manufacturer, and should of course be optimized by machinery, plant and cabinet builders based on their particular know-how.



For further assistance refer to the brochure titled "EMC-friendly cabinet design" from the Rittal corporation in Herborn, Germany (www.rittal.de).

5.5.5 Sixteen EMC measures to DIN VDE 0100 part 440



Any readers wishing to find further details on the subject of EMC are recommended to read the EMC Guide ["EMV-Fibel"] by Wilhelm Rudolph.

EMV-Fibel für Elektroinstallateure und Planer [EMC Guide for electricians and planners]

Wilhelm Rudolph
VDE-Verlag,
ISBN 3-8007-2613-0

The EMC Guide is intended for persons involved in practical applications - that is, the planners and installers involved on a daily basis with installation activities.

A key area of focus is on the points of contact between modern-day information technology and conventional power engineering which are of importance to EMC:

- Equipotential bonding
- Earthing
- Screening
- Isolation
- Suitable system forms (e.g. TN-S system)

The EMC Guide demonstrates that electromagnetic compatibility is attained in buildings by implementing sixteen measures.

They are:

1. Location of possible interference sources outside the sensitive range of susceptible equipment.
2. Location of susceptible equipment outside the range of influence of high-power structures (load stations, transformer stations), high-current busbars or high-power equipment, e.g. lift drives.
3. Installation of RFI filters or (and) surge voltage protectors in circuits supplying susceptible electrical equipment.
4. Selection of protective devices with suitable characteristics for time delay, to avoid undesirable triggering in response to transient (short-time) overvoltages.
5. Establishment of equipotential bonding for metal casings:
 - Equipotential bonding
 - Screening
 - Relieving conductors for cable and line screens
6. Adequate separation (distance or screening) and rectangular crossing of power and signal cables or lines.

7. Adequate separation (distance or screening) of power and signal cables or lines from lightning protection systems (LPS's).
8. Avoidance of induction loops by selecting common cable and line paths (or ducts) for different systems.
9. Use of signal cables or lines which are screened or (and) executed with twisted wire pairs.
10. Equipotential bonding conductors or connections should be executed as short as possible.
11. Cable and line installations with multiple single-core conductors should be routed in metal casings or equivalent devices.
12. Avoidance of TN-C systems in installations with sensitive IT equipment.
13. TN-C systems in buildings.
14. Equipotential bonding at line entry into buildings.
15. Measures for areas (buildings) with different (separate) equipotential bonding systems.
16. For existing installations (Measures for installations) which have not yet adequately met EMC requirements based on earlier norms.

5.6 Safety engineering for machines with power drives

In the following we provide an overview of the EN norms covering safety engineering for machines. Then we deal in detail with the subject of safety engineering for machines with power drives. We refer specifically to IEC 61800 part 5-2 (draft), EN 954-1 and EN 60204-1. Furthermore, in section 5.6.5 we provide an overview of the future standards EN ISO 13849 and EN ISO 62061. The standards referred to are not reprinted in full. We merely quote from their content, or indicate areas of application.

EN 954-1/ISO 13849: The EN 954-1 norm, in future EN ISO 13849 or EN ISO 62061, lays down safety standards under the terms of the German Equipment Safety Act. It covers all the components of a machine control deployed in safety tasks. The said components may be hardware (contactors, limit switches, programmable logic controls, servocontrollers, drive controllers and the like) and/or software (user programs, firmware and the like). The future norms (see section 5.6.5) apply with regard to their implementation in programmable systems.



Application of one of the two norms, EN ISO 13849 or EN ISO 62061, is adequate to conform to the protective goals set out in the EU Machinery Directive.

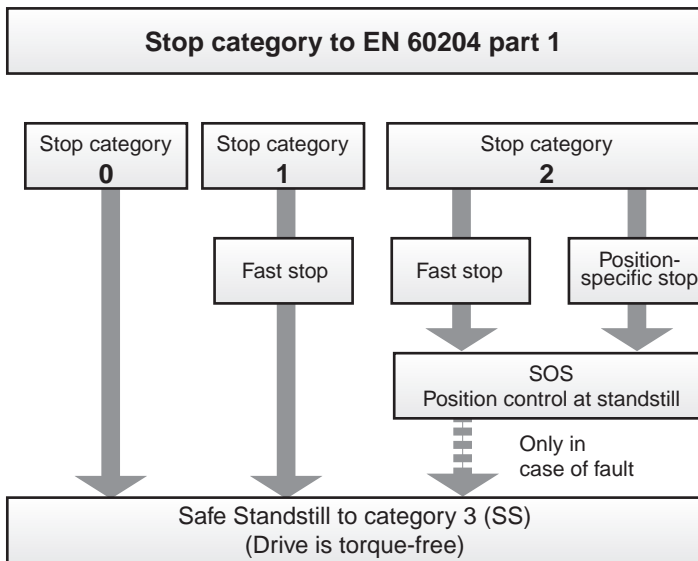
IEC 61800 part 5-2 (draft): The product norm IEC 61800 part 5-2 lays down requirements and provides recommendations for the development of variable-speed power drives suitable for use in safety applications. The norm is only applicable where the power drive is to be equipped with integrated safety systems.



The product norm IEC 61800-5-2 incorporates requirements from the EN 292, EN 1050, EN 9541 and IEC/EN 61508 norms and from the position paper DKE-AK 226.03.

EN 60204-1/IEC 60204-1 (rev. in preparation): The norm EN 60204 part 1 details various stop categories for differentiated shutdown of drives. Shutdown is not a stand-alone function, but describes the process which can be realized with the aid of a safety control. The future norms (see section 5.6.5) apply with regard to their implementation in programmable systems.

In practice, the functions are mostly realized with simple electromechanical components. You may, however, also be realized with programmable electronic variable-speed drives. Realization of the complex function with power drives is set out in Draft IEC 61800-5-2.



Stop category	System response/ Requirement	Example
0	Uncontrolled shutdown: By immediate cutting of the power to the machine drive elements.	The drive torque is cut by the "Safe Standstill (SS)" function. Any drive still in motion runs down to a stop.
1	Controlled shutdown: Power to the machine drive elements is maintained to bring about shutdown. The power is only cut when standstill is reached.	The drive is braked under speed control at the current limit and then switched to "Safe Standstill (SS)" mode.
2	Controlled shutdown: In which the power to the machine drive elements is also maintained at standstill.	The drive is braked under speed control and then switched to "Safe Operation" mode (position control at standstill).

Table 5.10 Stop category



Position paper DKE-AK 226.03

The position paper details the functions of power drive systems relating to the safety of personnel and lays down relevant requirements. Only power drive systems deployed primarily in machines and of which the electrical control components perform safety functions are considered.

The requirements set out in the position paper relate to the functional response of a drive system. The paper is an enhancement of EN 60204-1 referred to power drive systems, and serves, among other roles, as a discussion paper for drafting of the new norm EN 61800 part 5-2.

1

2

3

4

5

6

A

5.6.1 Guidelines and EN norm group

With effect from the beginning of 1995 the EU Machinery Directive has stipulated mandatory CE marking. It defines basic requirements for the safety of machines and thus for the protection of operators. The safety requirements are set out in the EN "Safety of machines" norms. The EN norms are divided into the principal groups A, B and C.

"A" norm

"A" norms set out basic terms, design principles and principles of risk assessment covering all machinery.

"B" norm

"B" norms comprise all norms containing safety standards which may relate to more than one kind of machine. "B" norms are important to all manufacturers of machinery to which no "C" norm applies.

"C" norm

"C" norms are norms covering specific machine types, such as machine tools, printing machines, lifts and so on. The "C" norms have priority over "A" and "B" norms.

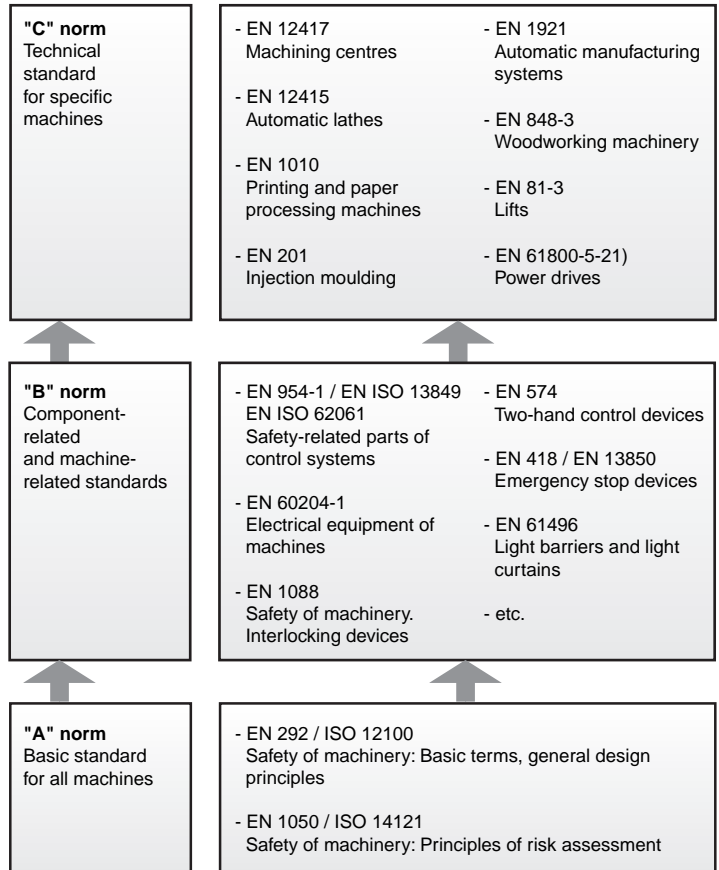
The machine manufacturers can thus assume that they are conforming to the basic requirement of the Machinery Directive (automatic assumption of conformity).



A new EU Machinery Directive is planned for mid 2007. There will be an 18-month transition period.

Changes are expected with regard to:

- Incomplete machines (partial machines)
 - MD Annex 1
 - Market supervision
 - Assessment of conformity
 - Safety modules
-



1) Harmonized under MRL from around 2006

Figure 5.21 Overview of key "A", "B" and "C" norms



You can find a complete listing of all standards cited and the mandated standardization projects on the Internet at:
<http://www.newapproach.org>

5.6.2 Risk assessment and reduction



Before a machine can be brought into circulation on the market, the machine's manufacturer must carry out a risk assessment in accordance with the EU Machinery Directive 98/37/EEC. The risk assessment determines all the potential hazards associated with use of the machine. The procedure is detailed in EN 1050 ("A" norm): "Principles for risk assessment". It represents an interactive process aimed at attaining safety.

Safety is a relative term in the technical environment. One hundred percent safety is sadly not feasible. The residual risk is defined as: "The risk remaining after implementation of the protective measures". The protective measures cited are the measures taken to reduce risk.

The risk assessment and the risk reduction measures establish the pre-conditions for specifying the category of safety-related parts of control systems to EN 954-1. The categories are graduated according to the level of risk, see Table 5.11. For more details on risk assessment and reduction and on determining the necessary control requirements refer to the applicable standards and legislation, as space does not allow us to detail them in this brief overview.

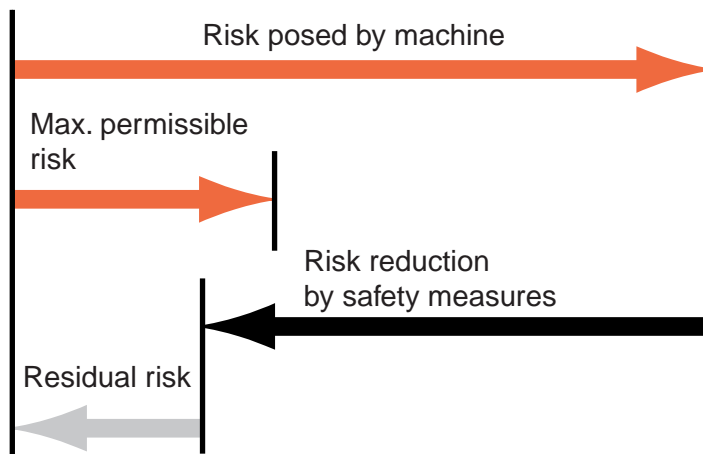


Figure 5.22 Risk assessment system

Safety category ¹⁾	Summary requirements	System response ²⁾	Principles for attaining safety
B	The safety-related parts of control systems and/or their protective devices and their components must be designed, built, selected, assembled and combined in conformance to the applicable standards such that they are able to withstand the expected influences.	The occurrence of a fault may lead to loss of the safety function.	Primarily characterized by selection of components
1	The requirements of B must be met. Tried and proven components and safety principles must be applied.	The occurrence of a fault may lead to loss of the safety function, but the likelihood of occurrence is less than in category B.	
2	The requirements of B must be met and tried and proven safety principles must be applied. The safety function must be tested at appropriate intervals by the machine control system.	<ul style="list-style-type: none"> The occurrence of a fault may lead to loss of the safety function between the testing points. Loss of the safety function is detected by the test. 	Primarily characterized by the structure
3	The requirements of B must be met and tried and proven safety principles must be applied. Safety-related parts must be designed such that: <ul style="list-style-type: none"> a single fault in any of the said parts does not result in loss of the safety function and whenever feasible in an appropriate manner, the single fault is detected. 	<ul style="list-style-type: none"> If the single fault occurs, the safety function is always maintained. Some - but not all - faults are detected. A series of undetected faults may lead to loss of the safety function. 	
4	The requirements of B must be met and tried and proven safety principles must be applied. Safety-related parts must be designed such that: <ul style="list-style-type: none"> a single fault in any of the said parts does not result in loss of the safety function and the single fault is detected on or before the next request to the safety function or, if this is not possible, a series of faults does not then lead to loss of the safety function. 	<ul style="list-style-type: none"> If faults occur, the safety function is always maintained. The faults are detected in time to prevent loss of the safety function. 	
1) The categories are not intended to be applied in any given sequence or hierarchical order with regard to the safety requirements. 2) The risk assessment will determine whether the complete or partial loss of the safety function(s) resulting from faults is acceptable.			

Table 5.11 Description of the requirements for determining safety categories to EN 954-1

5.6.3 "Safe Standstill" to EN 954-1 category 3



"Safe Standstill" to EN 954-1 designates a protective measure as an interlocking or control function. Category 3 signifies that when a single fault occurs the safety function is maintained. The safety-related parts must be designed such that:

- a single fault in any of the said parts does not result in loss of the safety function and
- whenever feasible in an appropriate manner, the single fault is detected.

For the "Safe Standstill" function to EN 954-1 category 3 the drive controllers are equipped with an integrated circuit with checkback contact. The logic cuts the power supply to the pulse amplifiers to activate the power stage. Combined with the "ENPO" controller enable, a two-channel block is placed on the occurrence in the power circuit of a pulse pattern suitable to generate a rotating field in the motor.

Important notes for implementation

Safety category: Responsibility for determining the safety category required for an application (risk reduction) lies with the machine builder.

Electrical isolation: The "Safe Standstill" function of the drive controller provides no electrical isolation. There is thus no protective function against electric shock hazard.

Action of external forces: If a drive system with the "Safe Standstill" function is expected to be subject to the action of external forces (e.g. dropping of suspended loads), additional measures must be taken to safety prevent movement (a mechanical brake).

Function testing:

You must always check the correct functioning of the "Safe Standstill, protection against unexpected start-up" function:

- on first commissioning,
 - after any modification of the system wiring,
 - after any replacement of one or more items of system equipment.
-



Short-circuit in the drive controller power pack:

Shorts in two remote branches of the power pack may activate a short-time axis movement dependent on the number of poles of the motor.

Example - synchronous motor: With a 6-pole synchronous motor the movement may be a maximum of 30 degrees. For a directly driven ball screw, e.g. 20 mm per revolution, this corresponds to a one-time maximum linear movement of 1.67 mm.

When using an asynchronous motor, the shorts in two remote branches of the power pack have virtually no effect, as the exciter field collapses when the inverter is disabled and has fully decayed after about 1 second.



Emergency off system:

Views expressed on this subject have become somewhat ambiguous, so in the following our comments are broken down into those relating to practice and those relating to the standard.

Practice: With the "Safe Standstill" function no emergency off is possible without additional measures. There is no electrical isolation between the motor and the drive controller.

Action in case of emergency to EN13850: EN 13850 (2004), relating to the safety of the machine's emergency stop, replaces EN 418 (Protection of machine emergency-off device).

New definition of terms:

EMERGENCY STOP for shutdown in emergency

Emergency stop is an action in case of emergency designed to stop a hazardous process or movement (EN 60204-1).

EMERGENCY OFF for switch-off in emergency

Emergency off is an emergency action designed to shut off the power supply source if there is a risk of electric shock or other electrical risk (EN 60204-1).

- 1) This solution provides an "emergency stop (SC3)" as per EN 13850 if the "short via emergency off 11/ 12" fault exclusion can be justified and documented, e.g. by appropriate cable layout or protective devices.

Safe Standstill (emergency stop) with CDE3000

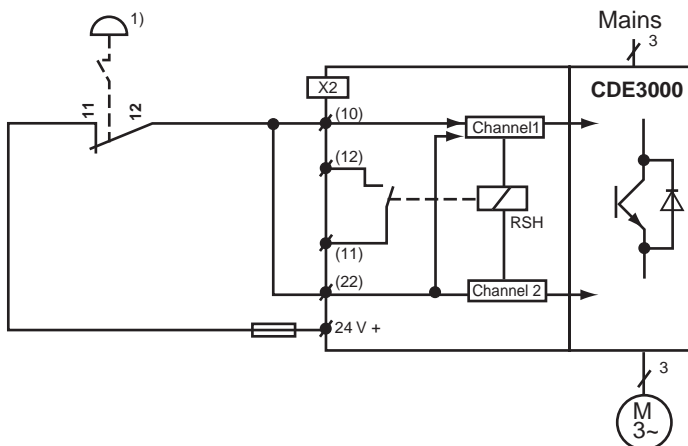


Figure 5.23 Request Safe Standstill for shutdown in emergency (emergency off shutdown)

ENPO	ISD00 (CDB) ISDSH (CDE)	Safe Standstill	Controller state	Relay ¹⁾ OSD02 / (CDB) ⁴⁾ RSH (CDE)
L	L	ON ³⁾	Power stage disabled over two channels. Hardware restart lockout active.	
L	(L) → H	ON	Power stage disabled over two channels. Hardware restart lockout active.	
(H) → L	H	OFF	Power stage disabled over one channel.	
H	L	ON	Power stage disabled over two channels. Hardware restart lockout active.	
H	(L) → H	ON	Power stage disabled over two channels. Hardware restart lockout active.	
(L) → H ²⁾	H ²⁾	OFF ³⁾	Power stage ready.	

() Preceding state
 1) 3 x 10⁶ switching cycles at 200 mA (rest: NO contact)
 2) To deactivate the restart lockout, the control signals must be set simultaneously (max. error 5 ms) to High (H) or ISD00 (ISDSH) must be set safely before ENPO to High (H)
 3) Switching combination for Safe Standstill, category 3
 4) CDB3000 is only available in special design with "Safe Standstill".

Circuitry examples with CDE3000 and safety relay module

The following circuitry examples were devised jointly with ELAN Schaltelemente GmbH & Co. KG. The suggested circuit designs are intended to provide an overview of the possible solutions. Please always check the suggested solutions are suitable to your specific application and draw up a validation plan.

Elan Schaltelemente GmbH & Co. KG
Im Ostpark 2
D-35435 Wettenberg
www.elan.de

Lust Antriebstechnik GmbH and ELAN Schaltelemente GmbH & Co KG can consequently accept no responsibility or liability for any loss resulting from use of the suggested circuit designs.

Validation: Does the solution meet the safety requirements?

Always draw up a validation plan. The plan details the tests and analyses you employed to establish the compliance of the solution (e.g. the proposed circuit diagram) with the requirements arising from your particular application case. Always check that

- all safety-related output signals are generated correctly and logically from the input signals.
- the response in case of a fault conforms to the specified circuit categories.
- the control system and the equipment are adequately dimensioned for all operation modes and ambient conditions.

On completing the analyses and tests draw up a validation report.

It should include as a minimum:

- all items to be tested
- the personnel responsible for testing
- test equipment (including details of calibration) and simulation instrumentation
- the tests performed
- the problems found and their remedies
- the results.

Retain the documented results in traceable form.

Advise the user of the correct usage, performance capability and performance limits of the safety-related parts.

Instruct the user how to maintain the performance capability of the safety-related parts, in particular when fault exclusions carried out by you necessitate special maintenance work.



In specifying safety categories (SCs) for the circuitry examples we carried out the following fault exclusion.

Fault exclusion:

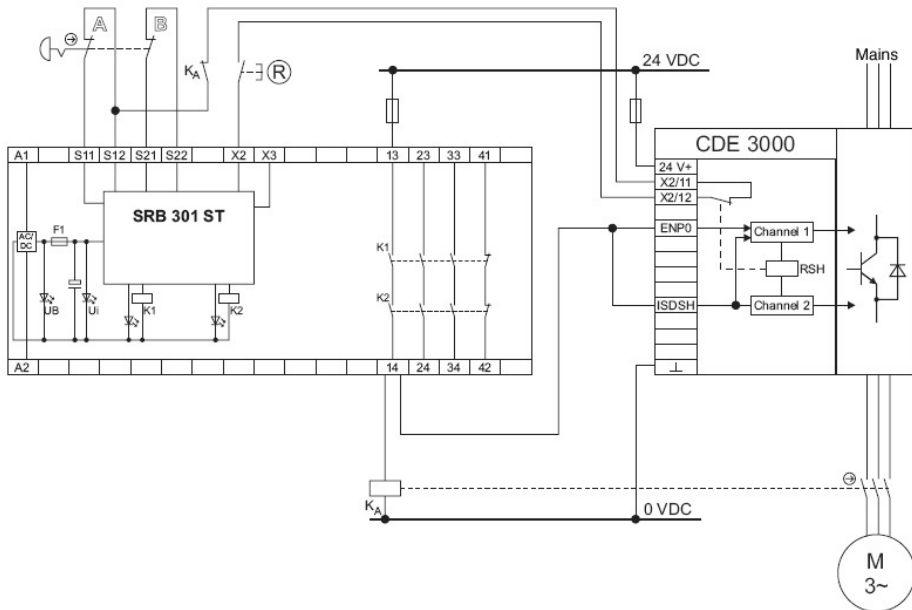
- Bridging within the wiring in the cabinet

Reason:

- Protected installation in cabinet; tried and proven technology
-

Two-channel emergency off/emergency stop circuit EN 418/ EN 60947-5-5 with cross-circuit detection

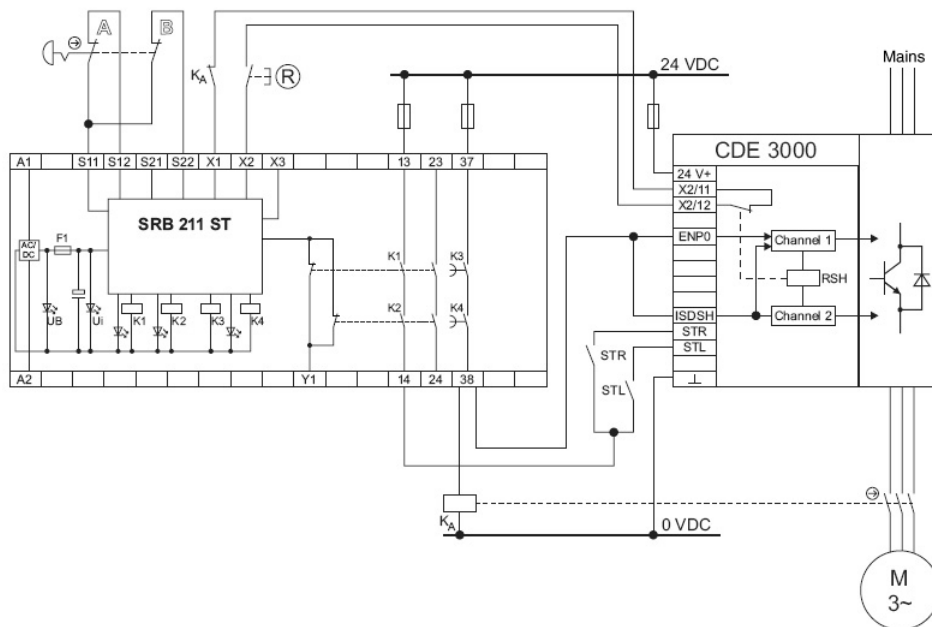
Configuration	Safety category (SC) EN 954-1	Stop category EN 60204-1
Sensor	SC4 with cross-circuit detection	-
CDE3000 with power contactor K_A	SC4 based on in-series configuration of power contactor K_A with positioning drive CDE3000 in SC3 design	Stop category 0 (uncontrolled shutdown)
CDE3000 without power contactor K_A	Emergency stop to EN 13850 with SC3 based on positioning drive CDE3000 in SC3 design	Stop category 0 (uncontrolled shutdown)



Where the drive controller and safety relay are installed in separate locations, preference should be given to the solution with power contactor K_A . It should be ensured that the wiring to K_A and CDE3000 is kept separate, or an appropriate fault exclusion (e.g. protective tubing) is executed.

Two-channel emergency off/emergency stop circuit EN 418/ EN 60947-5-5 with stop category 1 to EN 60204-1

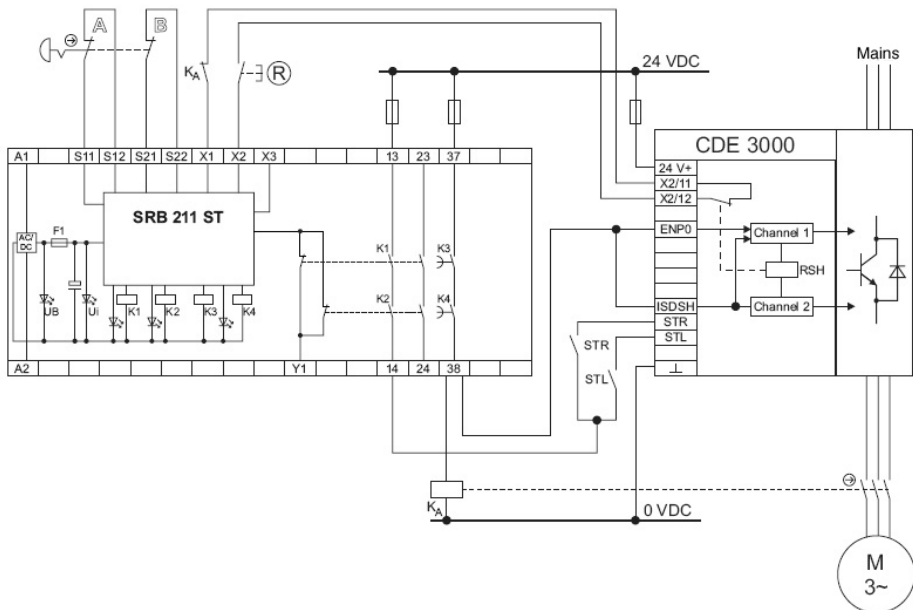
Configuration	Safety category (SC) EN 954-1	Stop category EN 60204-1
Sensor	SC3 without cross-circuit detection	-
CDE3000 with power contactor K_A	SC4 based on in-series configuration of power contactor K_A with positioning drive CDE3000 in SC3 design	Stop category 1 (controlled shutdown)
CDE3000 without power contactor K_A	Emergency stop to EN 13850 with SC3 based on positioning drive CDE3000 in SC3 design	Stop category 1 (controlled shutdown)



Where the drive controller and safety relay are installed in separate locations, preference should be given to the solution with power contactor K_A . It should be ensured that the wiring to K_A and CDE3000 is kept separate, or an appropriate fault exclusion (e.g. protective tubing) is executed.

Two-channel emergency off/emergency stop circuit EN 418/ EN 60947-5-5 with stop category 1 to EN 60204-1 and cross-circuit detection

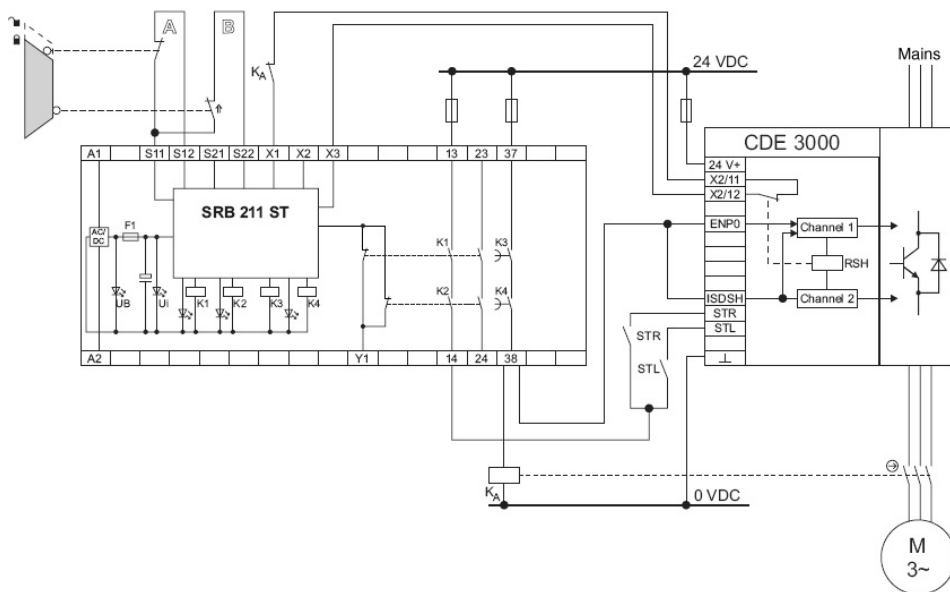
Configuration	Safety category (SC) EN 954-1	Stop category EN 60204-1
Sensor	SC4 with cross-circuit detection	-
CDE3000 with power contactor K_A	SC4 based on in-series configuration of power contactor K_A with positioning drive CDE3000 in SC3 design	Stop category 1 (controlled shutdown)
CDE3000 without power contactor K_A	Emergency stop to EN 13850 with SC3 based on positioning drive CDE3000 in SC3 design	Stop category 1 (controlled shutdown)



Where the drive controller and safety relay are installed in separate locations, preference should be given to the solution with power contactor K_A . It should be ensured that the wiring to K_A and CDE3000 is kept separate, or an appropriate fault exclusion (e.g. protective tubing) is executed.

Two-channel guard door monitoring to EN 1088 with at least one forced-opening position switch

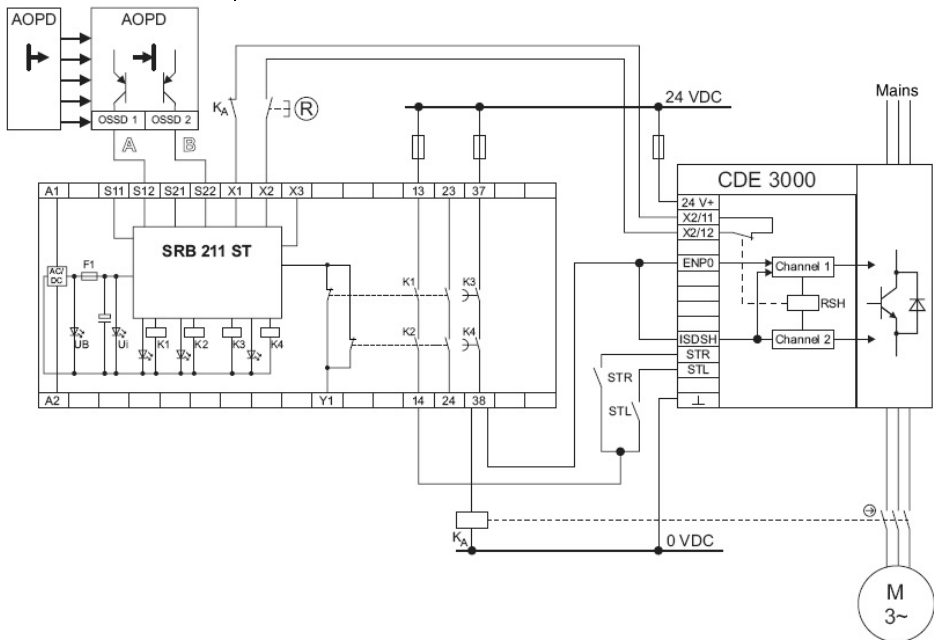
Configuration	Safety category (SC) EN 954-1	Stop category EN 60204-1
Sensor	SC3 without cross-circuit detection	-
CDE3000 with power contactor K_A	SC4 based on in-series configuration of power contactor K_A with positioning drive CDE3000 in SC3 design	Stop category 1 (controlled shutdown)
CDE3000 without power contactor K_A	Emergency stop to EN 13850 with SC3 based on positioning drive CDE3000 in SC3 design	Stop category 1 (controlled shutdown)



Where the drive controller and safety relay are installed in separate locations, preference should be given to the solution with power contactor K_A . It should be ensured that the wiring to K_A and CDE3000 is kept separate, or an appropriate fault exclusion (e.g. protective tubing) is executed.

Two-channel actuation with safety-oriented p-switching semiconductor elements, e.g. AOPD's to EN 61496

Configuration	Safety category (SC) EN 954-1	Stop category EN 60204-1
Sensor	SC3 with cross-circuit detection in sensor (not by safety relay)	-
CDE3000 with power contactor K_A	SC4 based on in-series configuration of power contactor K_A with positioning drive CDE3000 in SC3 design	Stop category 1 (controlled shutdown)
CDE3000 without power contactor K_A	Emergency stop to EN 13850 with SC3 based on positioning drive CDE3000 in SC3 design	Stop category 1 (controlled shutdown)



Where the drive controller and safety relay are installed in separate locations, preference should be given to the solution with power contactor K_A . It should be ensured that the wiring to K_A and CDE3000 is kept separate, or an appropriate fault exclusion (e.g. protective tubing) is executed.

Advantages of using drive controllers with certified "Safe Standstill" to EN 954-1, category 3

Benefits to you	Drive controllers with "Safe Standstill" control function	Conventional solution based on external switching elements
Reduced componentry and circuit complexity	<ul style="list-style-type: none"> • Easy procurement of certified safety function possible. • Group drive with one main contactor possible. 	Two safety-oriented power contactors in-series required.
Frequent routine testing permissible	The "Safe Standstill" state is attained by use of non-wearing electronic components.	This feature is not attainable by conventional technical means.
Short restart times	The drive controller is not disconnected from the mains on the power side, so no discernible wait times occur on restarting.	The drive must be disconnected from the mains on the power side, so ever longer restart times must be accepted.
Improved EMC	Improved EMC based on full screening of the motor cable.	Not possible based on power contactors in the motor cable.

Table 5.12 Advantages of using drive controllers with "Safe Standstill"

5.6.4 Safety functions for movement control

The basic principles of safety functions in drive systems are summarized in the position paper DKE-AK226.03.

The paper serves, among other roles, as a discussion paper for drafting the product norm EN 61800-5-2 (Development of variable-speed drive systems).

The paper details safety functions. Safety functions which ensure comparable safety to an isolating safety device and disconnection of the drive from the mains.

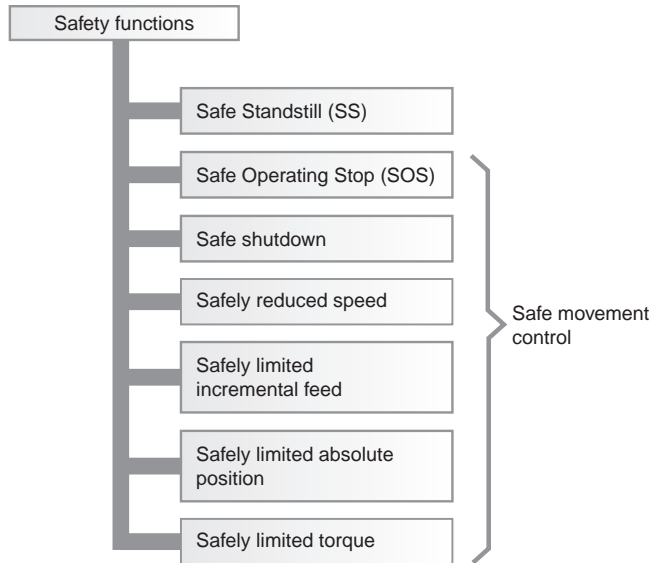


Figure 5.24 Safety functions

With the exception of the "Safe Standstill" (SS) function, all safety functions require an at least two-channel monitoring and shutdown principle. This requirement is met by means of a two-channel computer structure fulfilling the demands for safe movement control and of EN 954-1 category 3.

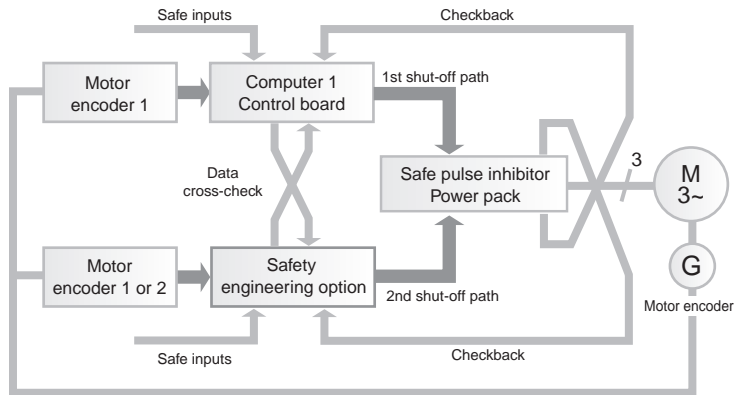


Figure 5.25 Two-channel computer structure for the safety function of a movement control

Movement control

In practice a motor encoder is in most cases replaced by a motor model implemented on the computer.

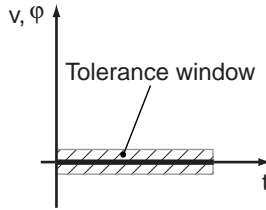
The signals generated in the encoders are evaluated over two channels by computers 1 and 2. This means velocity, position, end stop and cam monitors are implemented in two-channel mode. All safe inputs, e.g. for selecting the safety-related machine functions such as safely reduced velocity etc., are likewise implemented redundantly. The "pulse inhibitor" function block processes stop requests over two channels. In case of a fault (that is, if the safety function fails) both computers have an independent shutdown path.

In order to detect faults in the safety control system, both computers execute a cross-check of the safety-related data as well as self-tests. Inputs with slow or infrequent signal changes are checked by means of forced signal changes (forced dynamization). The outputs are tested in regularly required stop states (test stops).

The computer structure illustrated is implemented in different ways in practice. This section does not deal with that implementation as such, but with the safety function itself.

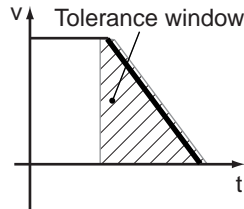
Safe Operating Stop (SOS)

Safety functions



Safe Operating Stop is the state in which the mechanical component is held at standstill, whereby the drive is in speed or position control mode.

Safe Standstill

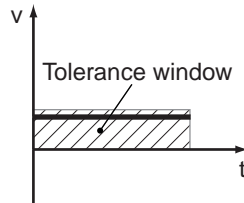


Standstill is the reduction of movement to a stop. The process begins with the stop request and ends when the movement has come to a standstill. The safety drive monitors the speed curve and, where appropriate, the time.



Safe Standstill: The Safe Standstill function can be executed in a range of variants. The variant applied depends on the machine and on the risk assessment. The variants (stop categories 0, 1, 2) are defined in EN 60204 part 1, see section 5.6.

Safely reduced speed

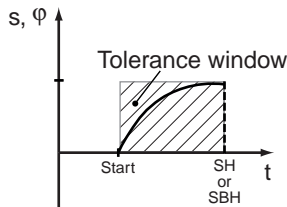


A reduced speed is set by the control system. The speed of a drive is monitored for exceeding of a maximum.



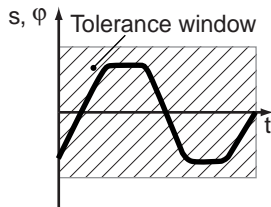
Safely reduced speed: Application of the "Safely reduced speed" function is subject to the proviso that a person is still able to escape danger arising from hazardous movements. Generally this can be assumed where the resultant speed of hazardous movements not involving risk of crushing and shearing does not exceed 15 m/min., and in the case of hazardous movements involving risk of crushing and shearing does not exceed 2 m/min.

Safely limited incremental feed



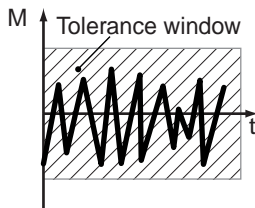
Limited incremental feed is a position change which begins at standstill, in which a pre-determined path/angle is covered and which ends at standstill. A preset incremental feed must not be exceeded. Then a "Safe Standstill" (SS) or "Safe Operating Stop" (SOS) takes effect.

Safely limited absolute position



The limited absolute position is the absolute position at which a movement must have come to a standstill. The position of a drive is monitored for exceeding of the permissible end position.

Safely limited torque



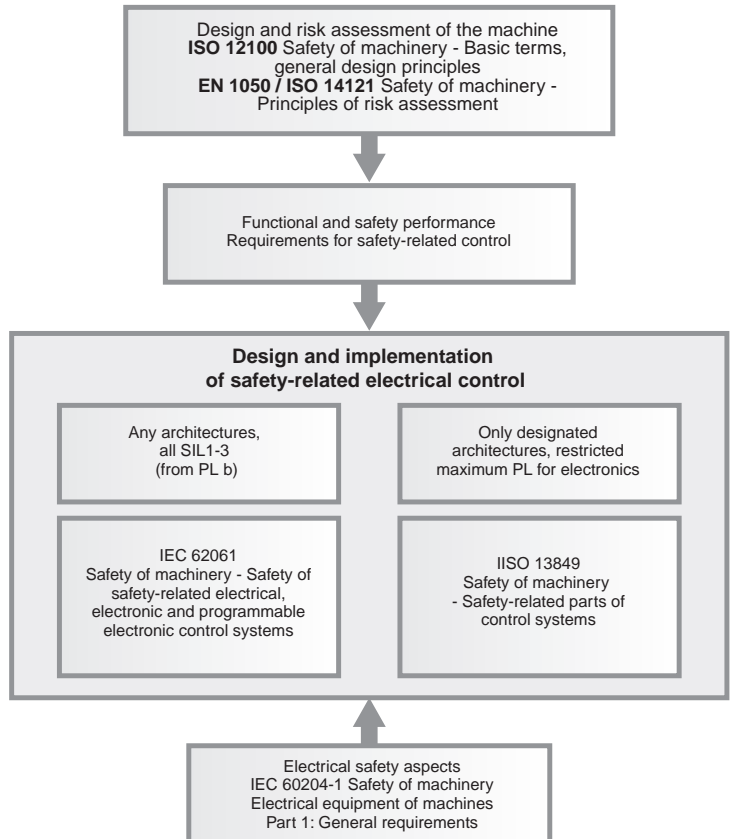
Monitoring of the torque of a drive for exceeding of the permissible maximums. The danger from hazardous movements is limited.

5.6.5 Application of future EN ISO 13849-1 (EN 954-1) and EN IEC 62061

The content of this section is based primarily on the ZVEI (German Electrical and Electronic Manufacturers' Association) Flyer issued in November 2004 titled "Anforderungen an moderne Steuerungssysteme für Sicherheitsaufgaben an Maschinen" [Requirements made of modern control systems for safety functions on machines].

Scope of the norm

The EU Machinery Directive stipulates that machines must be safe, and requires inherent safety as the primary design goal. To protect against hazards that cannot be eliminated by design additional safety devices must be installed. EN ISO 12100 parts 1 and 2 detail fundamental design principles and technical principles by which this goal can be attained. Where safety depends on control functions, the control system must be executed such that the likelihood of malfunction is suitably low. When using programmable electronic systems, the IEC 61508 standard must also be observed. EN ISO 13849 and EN IEC 62061 provide instructions specifically for the safety of machine control systems.



With regard to the potential hazards of a machine, risk assessments must be carried out in accordance with EN 1050 (in future EN ISO 14121) in order to ascertain whether adequate safety has been attained. The requirements of EN IEC 62061 and EN ISO 13849-1 relating to the implementation of safety-related control functions are classified according to the level of risk. The basis for this classification set out in EN IEC 62061 (as in IEC 61508) is the Safety Integrity Level (SIL) and in EN ISO 13849-1 the Performance Level (PL).

Performance Level (PL)		
Performance level (PL)	Average probability of a dangerous failure per hour [1/h]	SIL [EN 61508-1 (IEC 61508-D)]
a	$\geq 10^{-5}$ to $< 10^{-4}$	No special safety requirements
b	$\geq 3 \times 10^{-6}$ to $< 10^{-5}$	1
c	$\geq 10^{-6}$ to $< 3 \times 10^{-6}$	1
d	$\geq 10^{-7}$ to $< 10^{-6}$	2
e	$\geq 10^{-8}$ to $< 10^{-7}$	3
<p>NOTE 1 The performance for each hazardous situation in this standard is divided into five levels "a" to "e" where the risk reduction contributed by the SRP/CS in "a" is low and in "e" is high.</p> <p>NOTE 2 It should be noticed that performance levels b and c together cover only one order of magnitude on the scale of average probability of a dangerous failure per hour (or one step on the SIL scale).</p>		

Table 5.13 Comparison of Safety Integrity Level (SIL) and Performance Level (PL)

As there is no prospect of "testing out" all faults occurring in complex machine control systems once built, these standards also embody the all-embracing approach of aligning all development and project planning of safety-related control systems to the avoidance of faults from the very beginning. The two standards also share a probabilistic approach in determining hazardous failure rates.

The qualitative analysis as per EN 954-1 is no longer adequate to the technology of modern-day control systems. Among other criteria, EN 954-1 does not take into account time factors (e.g. test intervals and cyclic testing; lifetime). This resulted in the probabilistic approach embodied in IEC 61508, EN IEC 62061 and EN ISO 13849-1 (failure probability per time unit).

The areas of application of EN ISO 13849-1 and EN IEC 62061 are largely the same. Consequently, as a decision-making aid for users, the IEC and ISO committees have detailed the areas of application of the two standards in a single table contained in both their introductions.

Depending on the technology (mechanical, hydraulic, pneumatic, electrical, electronic, programmable electronic), risk classification and architecture, EN ISO 13849-1 or EN IEC 62061 will be applicable.

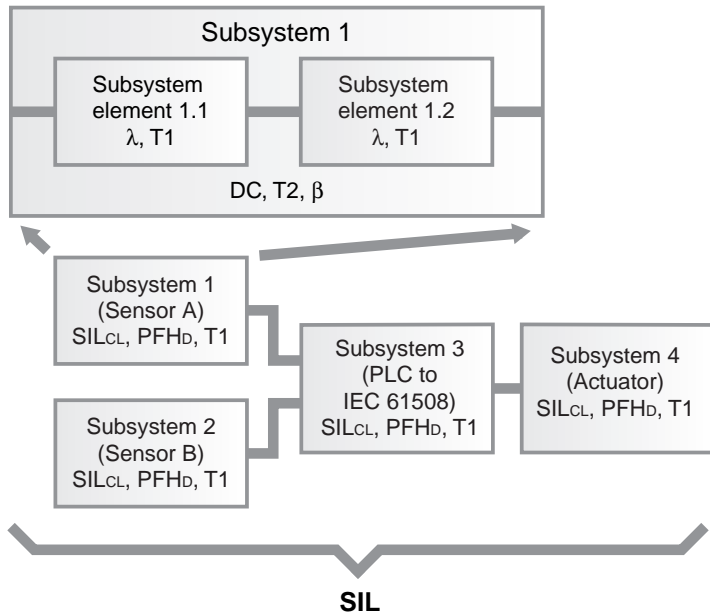
Technology implementing the safety-related control functions	EN ISO 13849-1 (rev)	EN IEC 62061
A Non-electrical, e.g hydraulic, pneumatic	X	Not covered
B Electromechanical, e.g. relays and/or simple electronics	Limited to designated architectures (see Note 1) and maximum PL = e	All architectures and up to SIL 3
C Complex electronics (e.g. programmable electronics)	Limited to designated architectures (see Note 1) and up to PL = d	All architectures and up to SIL 3
D A combined with B	Limited to designated architectures (see Note 1) and up to PL = e	X See Note 3
E C combined with B	Limited to designated architectures (see Note 1) and up to PL = d	All architectures and up to SIL 3
F C combined with A or C combined with A and B	X See Note 2	X See Note 3
<p>Note 1: Designated architectures are defined in Annex B of EN ISO 13849-1 and provide a simplified approach for quantification</p> <p>Note 2: For complex electronics: Use of designated architectures according to EN ISO 13849-1 up to PL = d or any architecture according to EN IEC 62061</p> <p>Note 3: For non-electrical technology: Use parts according to EN ISO 13849-1 (rev) as sub-systems.</p>		

Application of either of these standards can be presumed to fulfil the protective goals of the Machinery Directive.

EN IEC 62061: Safety-related electrical control systems for machines

EN IEC 62061 is a sector-specific norm subsidiary to IEC 61508. It details the implementation of safety-related electrical control systems of machines and considers the entire lifecycle from the concept phase through to decommissioning. The bases are quantitative and qualitative analyses of safety functions.

The standard applies a consistent top-down approach in the implementation of complex control systems, termed Functional Decomposition. Based on the safety functions resulting from the risk assessment, this establishes a breakdown by safety subfunction, and finally assigns those subfunctions to real equipment, termed subsystems and subsystem elements. Both hardware and software are covered. EN IEC 62061 also sets out requirements for the implementation of application programs.



A safety-related control system comprises various subsystems. The subsystems are classified in safety terms by their characteristics (SIL claim limit and PFH).

Safety characteristics of subsystems:

- SIL_{CL}: SIL claim limit
- PFH_D: Probability of dangerous failure per hour
- T₁: Lifetime

These subsystems may in turn comprise varyingly configured subsystem elements (equipment) with the characteristics determining the corresponding PFH rating of the subsystem concerned.

Safety characteristics of subsystem elements (equipment):

- λ : Failure rate; for elements subject to wear: BIO value
- T_1 : Lifetime

For electromechanical equipment the failure rate λ is specified by the manufacturer referred to a number of switching cycles. The time-based failure rate and the lifetime must be determined on the basis of the switching frequency for the application concerned.

Parameters to be specified in design of the subsystem comprising subsystem elements:

- T_2 : Diagnostic test interval
- β : Susceptibility to common cause failure
- DC: Diagnostic coverage

The PFH rating of the safety-related control system is determined by adding together the individual PFH values of the subsystems.

When constructing a safety-related control system the user has the following options:

- Use of equipment and subsystems already conforming to EN 954-1 and IEC 61508 or EN IEC 62061. For this the standard stipulates how qualifying equipment can be integrated in the implementation of safety functions.
- Development of dedicated subsystems
 - Programmable electronic systems and complex systems: Application of IEC 61508.
 - Simple equipment and subsystems: Application of EN IEC 62061.

There are no specifications relating to non-electrical systems however. The standard represents a comprehensive norm for implementing safety-related electrical, electronic and programmable electronic control systems.

For non-electrical systems EN 954-1 / EN ISO 13849-1 is applicable.

EN ISO 13849-1 is intended to supplant EN 954-1

EN ISO 13849-1 is based on the familiar categories from EN 954-1:1996. It now also considers complete safety functions with all the equipment involved in its execution.

EN ISO 13849-1 goes beyond the qualitative approach of EN 954-1 to also provide a quantitative analysis of the safety functions. Based on the categories, Performance Levels (PL's) are used for this. The following safety characteristics of components/equipment are required:

- **Category** (structural requirement)
- **PL**: Performance Level
- **MTTFd**: Mean time to dangerous failure
- **DC**: Diagnostic coverage
- **CCF**: Common cause failure

The standard details calculation of the Performance Level (PL) for safety-related parts of control systems based on designated architectures. In case of non-conformance to those architectures, EN ISO 13849-1 makes reference to IEC 61508.

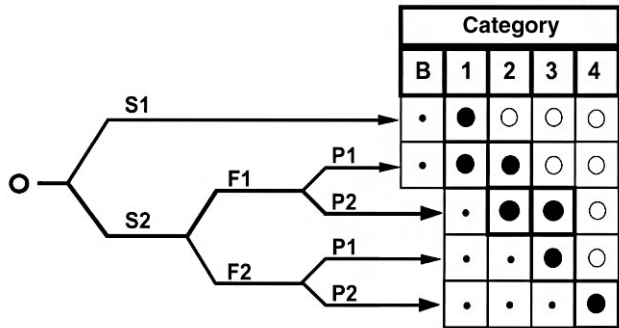
Where multiple safety-related parts are combined to form a single overall system, the standard sets out stipulations for determining the resultant PL.

For further information on validation EN ISO 13849-1 refers to part 2, which was published at the end of 2003. It contains stipulations regarding fault analysis, maintenance, technical documentation and directions for use.

IEC 61508 and EN IEC 62061 are also ratified as EN norms. EN ISO 13849-1 (rev) is in draft form. Until its adoption, scheduled for September 2005, EN 954-1:1996 will continue to apply. It must be assumed that EN ISO 13849 will be applicable as from 2006/7. It can therefore be estimated that EN 954-1 will be withdrawn and replaced by EN ISO 13845 around 2009/10.

Comparison of the old and new risk graphs

EN 954-1



S: Severity of injury
 F: Frequency and/or duration of hazard
 P: Possibility of avoiding hazard

EN ISO 13849

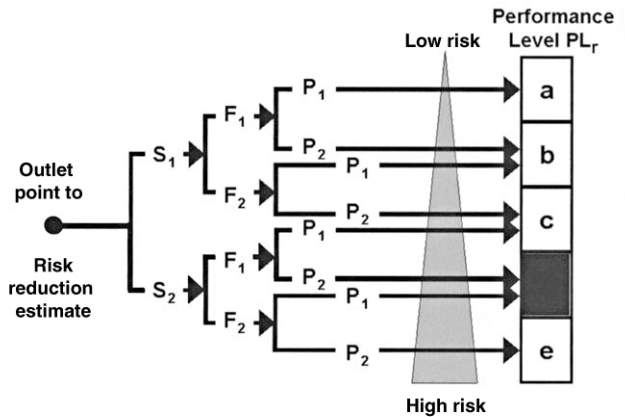


Figure 5.26 Risk graph - EN 954-1/ EN ISO 13849

Comparison chart of the various levels

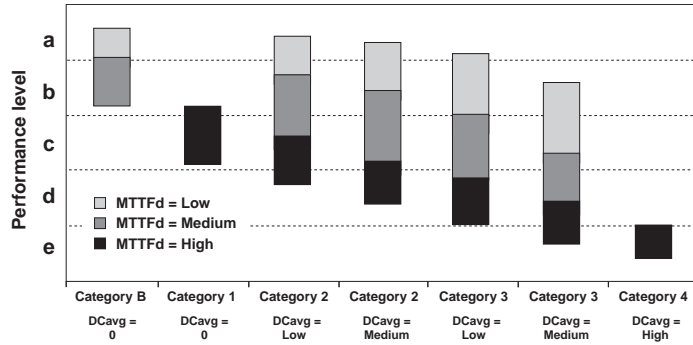


Figure 5.27 Simplified determination of Performance Level PL

EN 954-1 SC ¹⁾	EN ISO 13849-1 PL ²⁾	IEC 62061 SIL ³⁾	IEC 61508 SIL ³⁾
B	a	-	-
1	b	1	1
2	c		
3	d	2	2
4	e	3	3

1) Safety category
2) Performance Level
3) Safety Integrity Level

Table 5.14 Comparison chart of the various classification systems

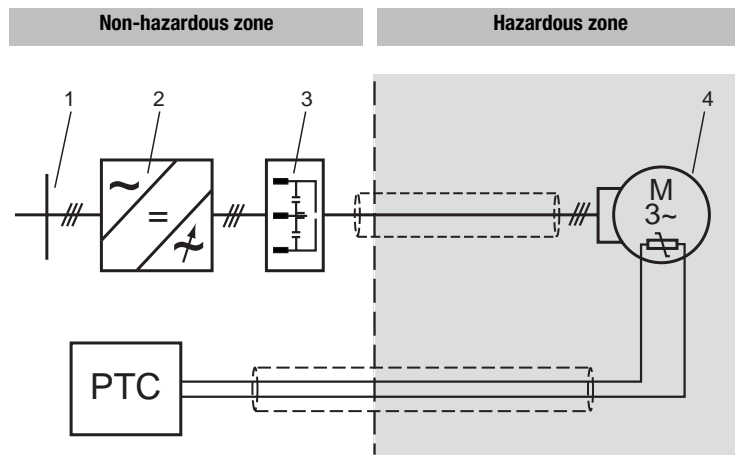
ISO	International Organization for Standardization www.iso.org
IEC	International Electrotechnical Commission www.iec.ch
CEN	European Committee for Standardization (Comité Européen de Normalisation) www.cenorm.be
CENELEC	European Committee for Electrotechnical Standardization Comité Européen de Normalisation en ELECTronique www.cenelec.org
DKE	Deutsche Kommission Elektrotechnik und Elektronik (German Commission for Electrical, Electronic & Information Technologies) www.dke.de
DIN	Deutsches Institut für Normung (German Institute for Standardization) www.din.de

5.7 Drive controller fed power drives in areas subject to explosion hazards

Automation of production processes in the chemical and petrochemical industries requires speed control of power drives. Implementation by means of drive controller drives is a tried and proven technique which has also established itself in the area of explosion protection.

Configurations of speed-controlled asynchronous three-phase AC motors in explosion-hazard zones comprise three or four items of equipment. They are the voltage DC-link drive controller, the asynchronous three-phase AC motor and the motor temperature monitoring unit, and depending on cable length also a du/dt motor choke or motor filter (sine filter).

The drive controller (motor filter) and the thermistor protective device are erected outside the hazardous zone and so not assigned a protection rating. The actual drive (the motor) is located in the hazardous zone and so is to be executed in flame-proof enclosure design, see Figure 5.28.



- 1) Mains
- 2) Drive controller
- 3) Motor filter
- 4) Ex-d motor

Figure 5.28 Schematic layout of a drive controller-fed drive in the hazardous zone

5.7.1 Motors of protection category "d"

EN60079-14



Motors of protection category "d" (flame-proof enclosure) may be operated without additional official testing and certification on any drive controller:

- provided the motor manufacturer has established the adequacy of the motor in a factory test
- and the motor has been certified by a generic certificate of conformity for temperature classes T1...T4 (recently also T6) with thermal motor protection (TNS) as sole protection
- and has been tested accordingly by the motor manufacturer.

The new European construction standard EN 60079-14 stipulates the following on this subject (paraphrasing):

Motors of protection category "d"

Motors fed with variable frequency and voltage require built-in thermistors specified in the documentation of the explosion-proof motor. The effect of the thermistor protection must be to shut down the motor. The motor/drive controller combination does not need to be tested together.

Protection category "d" - flame-proof enclosure

The basic concept underlying protection category "d" is to restrict any possible ignition to the interior of the motor enclosure and not allow it to flash over to the surrounding explosive atmosphere and cause spark ignition.

On the surface of the enclosure the temperature must not exceed the limit applicable to the respective temperature class.

The temperature of the winding is limited only by the thermal stability and ageing of the insulating materials used, and so may correspond to the values for normal, non-explosion-proof motors in accordance with Table 5.15.

Thermal class (insulating material class)	Temperature rise limit in K
B	80
F	105
H	125

Table 5.15 *Permissible temperature rise limits for insulated windings in continuous duty according to DIN EN 0034-1 / VDE 0530 part 1 (see also Table 5.16)*

The exterior of the enclosure is subject to limits indicated according to temperature class in Table 5.16.

Temperature class		Limit temperature in °C					
		T1	T2	T3	T4	T5	T6
Ignition temperature (EN 60079-14, Tab. 1)	>	450	300	200	135	100	85
Surface temperature (EN 60079-14, Tab. 1)	≤	450	300	200	135	100	85
Winding of class F continuous EEx d = normal (IEC 60034-1)	≤	145	145	145	145	100	85
Winding of class F continuous EEx e = reduced (EN 50019), Tab. 3)	≤	130	130	130	130	100	85
Winding of class F at end of t_E (EN 50019, Tab. 3)	≤	210	210	210	130	95	80
Cage at end of t_E (PBT test rules)	≤	290	290	195	130	95	80
		Depending on temperature of gas					
		Depending on thermal/insulating material class of winding					

Table 5.16 *Limit temperatures of electrical machines of protection categories "e" and "d"*

To comply with the enclosure temperatures cited in Table 5.16 DIN VDE 0165 and EN 60079-14 stipulate an overload protection. Selection of the overload cut-out switch is subject to the provisions of DIN VDE 0660 and EN 60947 - that is to say, the same criteria as for normal, non-explosion-proof motors.



Depending on cable length, du/dt motor chokes or motor filter, - so-called sine filters - are stipulated. In practice sine filters (motor filters) should be used, because only they also reduce the leakage currents.

5.7.2 Protection measures

To prevent electrical equipment from becoming sources of ignition, measures must be taken which are stipulated in detail in DIN-VDE standards and regulations. At present there are seven standardized protection categories for electrical equipment, subdivided into three groups (Table 5.17).

1. "Flame-proof enclosure" group

Protection is based on the principle that explosive atmosphere, which may ignite due to hot parts, arcing caused by operation or sparks, can penetrate the interior of the electrical equipment but the equipment is of such solid construction that it is able to withstand the explosive pressure, and arc-through of the hot combustion gases is prevented by seals.

This category of protection is termed "flame-proof enclosure", category "d". Technical embodiments include flame-proofing of the enclosure and of components.

Group	Protection	Schematic representation	Applications
1	Flame-proof enclosure d		Switchgear, command and display units, controls, motors, transformers, lights and other spark-generating parts
2	Increased safety e		Terminal and junction boxes, control boxes for installation of Ex components (covered by a different protection category).
	Intrinsic safety i		Instrumentation and control systems, communications systems
3	Pressurized enclosure p		For large-scale equipment and entire rooms
	Oil immersion o		Transformers (now rarely used)
	Powder filling q		Transformers, capacitors, heating conductor terminal boxes (used relatively rarely)
	Moulding m		Switchgear for small power outputs, command and signalling units, display units,
			Explosive atmosphere

Table 5.17 Protection categories to EN 50014 ... 50039 (DIN VDE 0170/0171)

2. "Increased safety" group

Protection is based on the principle that though explosive atmosphere can also penetrate the interior of the electrical equipment, ignition is prevented by avoiding hot parts, sparks or arcing.

This category of protection is termed "increased safety", category "e". It is applied to equipment which contains neither hot parts nor sparking parts, both in operation and in case of fault. This group also includes a protective principle in which the circuit permits no power higher than a power which is at all times lower than the minimum ignition power, so that neither heat-up nor sparking capable of causing ignition can occur. This category of protection is termed "intrinsic safety", category "i".

3. "Pressurized enclosure" group

Explosive atmosphere is prevented from reaching parts causing ignition. In the "pressurized enclosure" protection category this is achieved by maintaining a constant positive pressure inside the enclosure which prevents the penetration of explosive atmosphere,

either by a static pressure or in the form of continuous flushing. In the "oil immersion" protection category "o", the space remaining inside an item of electrical equipment is filled with oil.

In the "powder filling" protection category "q", the remaining space is filled with sand or mineral granulate. In the "moulding" protection category "m", the interior is filled with moulding compound. There is also a protection category designated "special protection", category "s". This protection category is as safe as the above categories.

5.8 Fault current monitoring in electrical installations with power drive systems

Protective measures for high-current systems up to 1000 V are set out in DIN VDE 0100-410 issued in 1997. The standard stipulates protection against electric shock by the application of suitable measures. The measures relate to normal operation and in case of fault.

Protection against electric shock under fault conditions can be implemented by automatic shut-off of the power supply.

Recognized protective devices:

- In the TN system Overcurrent protective devices and RCDs/RCMs
- In the TT system Overcurrent protective devices and RCDs/RCMs
- In the IT system Insulation monitoring device, overcurrent protective device and RCD

According to DIN EN 62020 (VDE 0663) for residual current monitors (RCMs) these devices are to be used in conjunction with the protective devices listed above.

In contrast to insulation monitoring devices, RCMs use the residual current dependent on the discharge impedance. It contains capacitive and ohmic components. Based on the monitoring of increases in this residual current, it can, however, be said that the earthed system also has a quasi form of insulation monitoring, as increases in the residual current are caused in the vast majority of cases by deterioration of the insulation resistance.



Definition of terms:

Fault current breaker Equivalent to the term "RCD" (Residual Current Protective Device) used in the standard.

RCM (Residual Current Monitor)

An RCM is a device which monitors the residual current of an electrical system and signals if the residual current exceeds the RCM's response threshold.

RCD (Residual Current Protective Device)

An RCD is a device which monitors the residual current of an electrical system and shuts down parts of the system if the residual current exceeds the RCM's response threshold.

Residual current

The sum of the instantaneous values of currents flowing at one point in the electrical system through all active conductors of a circuit.

Leakage current

A current which flows to earth or to an external conductive part in a fault-free circuit.

Fault current

The current caused to flow by an insulation fault.

Rated fault current

Fault current at which an RCM is activated under specific conditions.

Fault current breaker type A

RCDs which do not register direct currents.

Fault current breaker type B

RCMs which register direct currents and mixed currents.



The common fault current breakers (RCD type A) cannot register direct current. For this reason, the use of so-called "all-current sensitive fault current breakers" should be planned, designated in IEC 60755 as type B with regard to fault current form.

5.8.1 Basic measurement method for RCMs/RCDs (type A)

The mode of operation of all residual current monitoring devices is based on the same residual current principle. In this, all conductors of the outlet being protected (except the PE conductor) are routed through a core balance transformer with a secondary winding. In a fault-free power supply and distribution system the vectorial sum of all currents is then equal to zero, so that in the transformer secondary winding no voltage is induced. If, by contrast, a residual current is discharged via earth, the current difference results in a current in the core balance transformer which is evaluated by the electronics (RCM) or triggers a switching operation (RCD).

Conventional type A RCMs/RCDs work on the principle of measurement transformers as current transformers. The residual current I_{Δ} is transformed by way of a number of turns N . This results in a measurement voltage at the measurement resistor R_{Load} with the following quantity:

$$U_m = \frac{R_{Load} \cdot I_{\Delta}}{N}$$



This method is not suitable for detecting direct currents or alternating currents with direct current components, as the measurement transformer is only able to transmit current changes.

5.8.2 All-current sensitive fault current breaker monitoring (RCM, type B) in earthed systems

In many areas consumers which in response to insulation faults cause DC fault currents without zero crossing are being more and more frequently deployed. Examples include power drive controllers, uninterruptible power supply units, X-ray machines, welders and equipment and systems with multi-pulse three-phase bridge connections.

DC fault currents may, however, have a negative influence on the triggering response of type A RCDs, as they cause a DC pre-magnetization of the magnetic core in the residual current sensor. Consequently, for electrical consumer equipment which generates such smooth DC fault currents in case of fault, all-current sensitive fault current breakers (RCM type B) must be used.

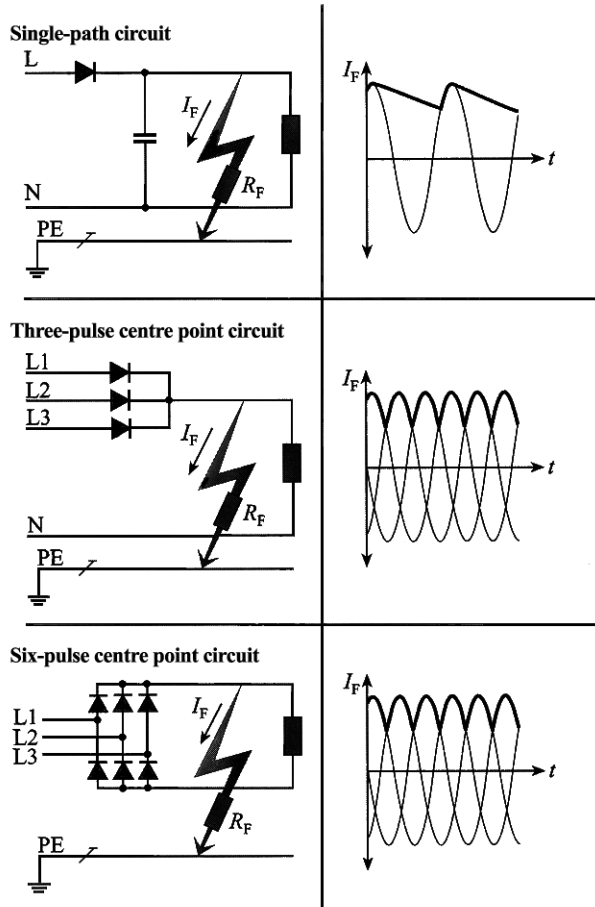


Figure 5.29 Fault currents without zero crossing

Measurement method for all-current sensitive type B RCMs



All-current sensitive type B RCMs work, for example, on the principle of magnetic compensation. This means they are suitable for detecting direct, alternating and mixed currents. On the measurement transformer there are two windings, each with the same number of turns, whereby the said transformer is integrated as an oscillation generator in a normal-mode oscillator.

Based on the oscillator principle, the characteristic line of the core is continuously passed through at the oscillation frequency into the saturation range. This compensates for DC magnetization. The compensation current generated by the oscillator is influenced proportionally by the AC and DC components of the residual current and is electronically evaluated.

The basis for selection of protective measures on electronic equipment, such as electronic drive controllers, which cause fault currents without zero crossing in case of fault is DIN VDE 0160/EN 50178.

It stipulates: Electronic equipment must be designed and manufactured such that when working without fault in correct operation and in its intended use it fulfils its function and poses no hazard to human beings.

In practice this means that an adequate insulation resistance must be in place and that a decrease in insulation resistance must be detected in good time.

The general requirements with regard to the source power supply and distribution system and to RCDs are defined in DIN VDE 0160 section 6.3:

- Before connecting an item of electronic equipment to a system with fault current breakers, their compatibility must be checked.
-



If they are incompatible, protection in case of indirect touch contact is to be established by other means

Fault current breaker compatibility means that electronic equipment must be designed such that in accordance with DIN VDE 0664:

- the tripping of an upstream fault current breaker is not prevented in the case of a direct current component in the fault current;
 - the tripping of an upstream fault current breaker resulting from leakage currents, e.g. due to suppression capacitors, does not occur prematurely;
 - the operating documentation contains a warning prohibiting connection to the mains when solely using fault current breakers.
-

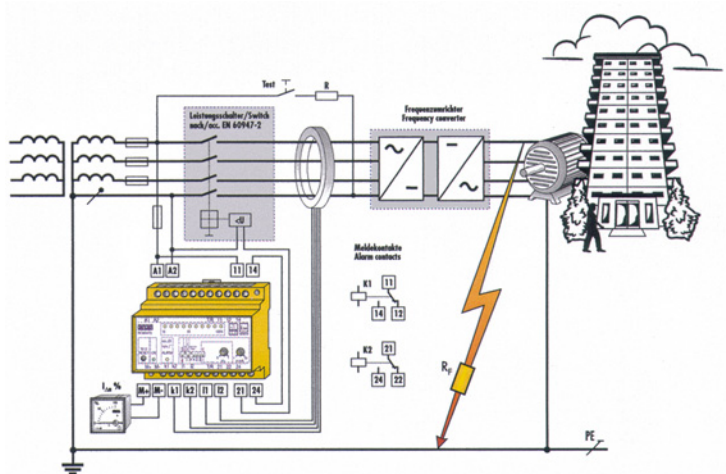
5.8.3 All-current sensitive residual current monitoring in passenger and goods lifts



The following application report was submitted to us by

Dipl.-Ing. W. Bender GmbH & Co. KG
 Londorfer Straße 65
 D-35305 Grünberg
 www.bender-de.com

This circuitry proposal was drawn up with due diligence. Users are, however, obligated to check the functionality for their specific intended application case. Subject to change without notice.



The drive controller interposed between the three-phase supply system and the drive machine poses the risk that the conventional protective measures against excessive touch voltage in the event of a motor-side fault to frame would not be adequate. Moreover, the current-limiting function of the drive controller (fuse does not trip in case of fault to earth or frame) and its system-side filtering to comply with EMC regulations (high C_E leakage currents lead to tripping of the RCD) make the use of protective devices more difficult.

To provide this solution, the all-current sensitive RCMAs (type B) are deployed in conjunction with a power switch to EN 60947-2. This installation then provides comprehensive protection against all known fault and residual current types.

If the preset response threshold is exceeded, the signalling contacts trip the undervoltage release of the power switch. The variable response threshold of 30 mA-3 A and the variable response time of 0-10 s enable optimum adaptation to the system. Operators are additionally assisted by the LED bar indicator showing the residual current. This enables changes in the residual current to be easily detected.

- **High electrical safety** based on all-current sensitive residual current monitoring with RCMA
- **Detects and signals all fault and residual current types**
also smooth direct fault currents
- **Optimum adaptation to the system**
based on adjustable response threshold
- **Supports preventive maintenance**
based on LED bar chart display of residual current
- **Reliable protective device in conjunction with switching device to EN 60947-2**

6 Drive definition

6.1	Drive definition via power rating	6-2
6.1.1	Traction drive	6-3
6.1.2	Lifting drive	6-5

6.1 Drive definition via power rating

D The method of power rating is principally used in three areas of application. They are:

1. Metalworking machinery (milling, drilling, grinding, etc.)
2. Process engineering (pumps/fans, extruder, etc.)
3. General engineering (packaging and special machinery, manipulators and conveyor systems, etc.)

The equations relating to areas of application 1 and 2 and their application are described in the Appendix.

The following deals with **area of application 3** and thus with the design of traction and lifting drives.

Packaging machinery	Manipulators	Conveyor systems	General engineering
<ul style="list-style-type: none"> • Puller drive (cladding removal, sheet feed) • Metering drive (volume metering, screw-type metering) • Traction/lifting axis (packers, palletizers) • Belt drive (bucket conveyor, product loading belt) • Labelling machine (X/Y drive) • etc. 	<ul style="list-style-type: none"> • Travelling axis, X/Z-axis • Lifting axis, Y-axis • Indexing table drive • Gripper drive • etc. 	<ul style="list-style-type: none"> • Trolley drive with 1, 2 and 4 motors • Crane lifting gear, trolley and running gear • Conveyor belt • Door drive • Shelf conveyor • Parquet flooring conveyor belt • Roller and chain drive • etc. 	<ul style="list-style-type: none"> • Metalworking machinery • Cross-cutters • All kinds of special machinery • etc.

Table 5.18 Typical examples of power rating from area of application 3

6.1.1 Traction drive

Example: Z-axis of a manipulator

$$\begin{aligned} m &= 51.5 \text{ kg} & \eta &= 0.88 \\ a &= 3 \text{ m/s}^2 & t_a &= 0.5 \\ v &= 1.5 \text{ m/s} & \mu &= 0.01 \end{aligned}$$

1. Determine power requirement to move the application

$$P_a = \frac{m \cdot a \cdot v}{\eta} = \frac{51,5\text{kg} \cdot 3\text{m/s}^2 \cdot 1,5\text{m/s}}{0,88} = 264\text{W}$$

$$P_F = \frac{m \cdot g \cdot \mu \cdot v}{\eta} = \frac{51,5\text{kg} \cdot 9,8\text{m/s}^2 \cdot 0,01 \cdot 1,5\text{m/s}}{0,88} = 9\text{W}$$

$$P_{\text{Drive}} = P_a + P_F = 273\text{W}$$

2. Select motor

The selected motor must have a power rating higher than P_{Drive} .
Select the motor from the list.

Selected motor: Type 71L/4, 370W, $J_M = 0.00073 \text{ kgm}^2$
The motor is to be run at max. 2000 rpm
(70 Hz characteristic).

$$P_{aR} = \frac{J_M \cdot n_M^2}{91,2 \cdot t_a} = \frac{0,00073\text{kgm}^2 \cdot 2000^2\text{min}^{-1}}{91,2 \cdot 0,5} = 65\text{W}$$

3. Calculate gross output

$$P_{\text{Gross}} = P_a + P_F + P_{aR} = 264\text{W} + 9\text{W} + 65\text{W} = 338\text{W}$$



For more details on "Selection of drive controllers" refer to sections 3.3 to 3.6.

Abbreviations used

P_a	Power to accelerate the load	[W]
P_{aR}	Power to accelerate the rotor	[W]
P_F	Power to overcome the tractive resistance/friction	[W]
P_H	Power to lift the load	[W]
m	Total mass	[kg]
a	Acceleration	[m/s ²]
v	Velocity	[ms]
μ	Tractive resistance/Coefficient of friction	
η	Efficiency of the drive solution	
g	Acceleration due to gravity	[9.8m/s ²]
J_M	Moment of inertia of selected motor	[kgm ²]
n_M	Max. speed of selected motor	[rpm]
t_a	Acceleration time	[s]



For typical motor moments of inertia refer to the Appendix A.4.

6.1.2 Lifting drive

Example: Z-axis of a manipulator

$$\begin{aligned} m &= 2.5 \text{ kg} & \eta &= 0.88 \\ a &= 10 \text{ m/s}^2 & t_a &= 0.15 \\ v &= 1.5 \text{ m/s} & \mu &= 0.01 \end{aligned}$$

1. Determine power requirement to move the application

$$P_a = \frac{m \cdot a \cdot v}{\eta} = \frac{2,5\text{kg} \cdot 10\text{m/s}^2 \cdot 1,5\text{m/s}}{0,88} = 43\text{W}$$

$$P_F = \frac{m \cdot g \cdot \mu \cdot v}{\eta} = \frac{2,5\text{kg} \cdot 9,8\text{m/s}^2 \cdot 0,01 \cdot 1,5\text{m/s}}{0,88} = 1\text{W}$$

$$P_H = \frac{m \cdot g \cdot v}{\eta} = \frac{2,5\text{kg} \cdot 9,8\text{m/s}^2 \cdot 1,5\text{m/s}}{0,88} = 42\text{W}$$

$$P_{\text{Lift}} = P_a + P_F + P_H = 86\text{W}$$

2. Select motor

The selected motor must have a power rating higher than P_{Lift} .
Select the motor from the list.

Selected motor: Type 71S/4, 250W, $I_M = 0.00056 \text{ kgm}^2$
The motor is to be run at max. 2000 rpm
(70 Hz characteristic).

$$P_{aR} = \frac{J_M \cdot n_M^2}{91,2 \cdot t_a} = \frac{0,00056\text{kgm}^2 \cdot 2000^2\text{min}^{-1}}{91,2 \cdot 0,15} = 164\text{W}$$

3. Calculate gross output

$$P_{\text{Gross}} = P_a + P_F + P_H + P_{aR} = 43\text{W} + 1\text{W} + 42\text{W} + 164\text{W} = 250\text{W}$$



For more details on "Selection of drive controllers" refer to sections 3.3 to 3.6.

Appendix A Practical Guide

A.1	Mathematical symbols.....	A-3
A.1.1	SI units	A-3
A.1.2	Important units	A-5
A.2	Drive engineering equations.....	A-6
A.2.1	Basic physical equations.....	A-6
A.2.2	Power	A-7
A.2.3	Torques	A-12
A.2.4	Work.....	A-13
A.2.5	Friction	A-15
A.2.6	Effective motor torque/power output.....	A-16
A.2.7	Choice of max. acceleration	A-19
A.2.8	Mass moments of inertia	A-22
A.2.9	Optimum transmission ratio	A-28
A.2.10	v/t diagram	A-29
A.2.11	Efficiencies, coefficients of friction and density ..	A-32
A.2.12	Definitions of lateral forces	A-36
A.2.13	Autotransformer.....	A-37
A.2.14	Line choke	A-38
A.3	Drive controller.....	A-39
A.3.1	Voltage Frequency Control (VFC)	A-39
A.3.2	Basic principle of Sensorless Flux Control (SFC) .	A-44
A.3.3	Torque formation of synchronous and asynchronous motors.....	A-45
A.3.4	Basics of closed-loop control	A-48
A.3.5	Basic principle of torque, speed and position control	A-58
A.3.6	DC network operation	A-63
A.4	Motors	A-67

A.4.1	Thermal classes of electric motors	A-67
A.4.2	Colour coding of a threshold value PTC to DIN 44081	A-69
A.4.3	Linear PTC KTY-130-gel	A-72
A.4.4	Motor protection possibilities	A-73
A.4.5	Typical data of standard three-phase AC motors	A-74
A.4.6	Typical data of asynchronous servomotors	A-77
A.4.7	Overview of data of synchronous servomotors (LSH)	A-79
A.4.8	Typical data of EUSAS system motors	A-80
A.4.9	Typical data of slim-line three-phase AC motors made of extruded aluminium section	A-85
A.4.10	New connection markings for rotating electrical machines	A-87
A.5	Protection	A-91
A.5.1	Protection/IP code to IEC/EN	A-91
A.5.2	Protection to EEMAC and Nema	A-98
A.5.3	Cable glands with PG/metric thread	A-100
A.5.4	Outer diameters of wires and cables.....	A-101
A.5.5	Current capacity of PVC-insulated copper wires	A-103
A.5.6	Colour coding for pushbuttons/controls.....	A-105
A.5.7	Colours of indicator lights	A-106
A.5.8	Standardized Transverse section of round conductors (ISO/AWG).....	A-107

A.1 Mathematical symbols

Appendix

Equality and inequality			
~	proportional	<	less than
≈	about, approximately	>	greater than
=	equal to	≥	greater than or equal to
≅	corresponding to	≤	less than or equal to
≡	identically equal	«	very small against
≠	not identically equal	»	very large against
≠	not equal, unequal		

Table A.1 Mathematical symbols

Geometric symbols			
	parallel	≅	congruent
⊥	not parallel	∠	angle
↑ ↑	equivalent to parallel	\overline{AB}	distance AB
↑ ↓	opposite to parallel	\widehat{AB}	arc AB
⊥	rectangular to, perpendicular to	~	similar
Δ	Delta		

Table A.2 Geometric symbols

A.1.1 SI units

Variable	Formula symbol	Units		Formula (A Cross-sectional area)
		Name	Abbreviation	
Voltage	U	Volt	V	$U = I \cdot R$
Current rating	I	Ampere	A	$I = U/R$
Resistance	R	Ohm	Ω	$R = U/I$
Conductivity, elec.	G	Siemens	S, 1/Ω	$G = 1/R$
Spec. el. resistance	ρ	Ohm/m	Ωm; Vm/A	$\rho = 1/\sigma$
El. conductivity	α χ	Siemens/m	S/m; A/Vm	$\sigma = 1/\rho$

Note: For vector values many formula symbols are designated by German letters.

Table A.3 SI units

Variable	Formula symbol	Units		Formula (A Cross-sectional area)
		Name	Abbreviation	
Frequency (c speed of light)	f	Hertz	Hz, (kHz)	$f = c/\lambda$
Wavelength	λ	Meter	m, (cm)	$\lambda = c/f$
Electrical charge	Q	Coulomb	C, As	$Q = I \cdot t$
Capacitance	C	Farad	F	$C = Q/U$
Inductance	L	Henry	H; Vs/A	
Power	P	Watt, Joule/s	W; VA, J/s	$P = U \cdot I$
Work	W, A	Joule	J; Ws	$W = P \cdot t$
Force, (weight)	F, (G)	Joule/m	J/m; Ws/m	$F = W/l$
El. field strength	E	Volt/m	V/m; N/C	$E = U/l$
Dielectric const.	ϵ	Farad/m	F/m; C/Vm	$\epsilon = c \cdot 1/A$
El. field constant, var.	ϵ_0	Farad/m	F/m; C/Vm	$\epsilon = \epsilon_0 \cdot \epsilon_r$
Dielectric constant	ϵ_r	-	-	$\epsilon_r = \epsilon/\epsilon_0$
El. displacement flux	ψ	Coulomb	C, As	
El. displacement density	D	Coulomb/m ²	C/m ²	$D = Q/A$
El. current density	S, (i)	Ampere/m ²	A/m ²	$S = I/A$
El. loading	θ	Ampere	A; J/Wb	$\theta = H \cdot l$
Magn. flux	Φ	Weber, Maxwell	Wb; Vs; M	$\Phi = B \cdot A$
Magn. voltage	V	Ampere	A; J/Wb	$V = H \cdot s$
Magn. field strength	H	Amp./m; Oerstedt	A/m; N/Wb, (Ö)	$H = B/\mu = l \cdot w/l$
Magn. inductance (flux density)	B	Tesla; Weber/m ² (Gauss)	T; Wb/m ² (G)	$B = \mu \cdot H$
Magn. field constant	μ_0	Henry/m	H/m; Wb/Am	$\mu_0 = 4\pi/10^7$
Permeability, absolute	μ	Henry/m	H/m; Wb/Am	$\mu = B/H$
Permeability coefficient	μ_t	-	-	$\mu_t = \mu/\mu_0$
Magn. polarization	J	Tesla; Weber/m ²	T; Wb/m ²	$J = B \cdot \mu_0$

Note: For vector values many formula symbols are designated by German letters.

Table A.3 SI units

Variable	Formula symbol	Units		Formula (A Cross-sectional area)
		Name	Abbreviation	
Magnetization intensity	M	Webermeter	Wbm; Vsm	$M = J/\mu_0 \cdot H$
Magn. conductivity	Λ	Henry	H	$\Lambda = 1/R_m$
Magn. resistance	R	$10^8/\text{Henry}$	$10^8/\text{H}$	$R_m = 1/A \cdot \mu$
El. susceptibility	χ	-	-	$= 4\pi \chi'$
Magn. susceptibility	χ	-	-	$= M/H = \mu_r - 1$

Note: For vector values many formula symbols are designated by German letters.

Table A.3 SI units

A.1.2 Important units

Important units
Force
$1\text{N} = 1 \frac{\text{kg} \cdot \text{m}}{\text{s}^2}$
Force
$1\text{kp} = 9.80665\text{N}$
Power
$1\text{PS} = 75 \frac{\text{kp} \cdot \text{m}}{\text{s}} = 0,7355\text{kW} = 735,5 \frac{\text{kg} \cdot \text{m}^2}{\text{s}^3} = 735,5 \frac{\text{Nm}}{\text{s}}$
Work, energy
$1\text{Ws} = 1\text{Nm} = 1\text{J} = 1 \frac{\text{kg} \cdot \text{m}^2}{\text{s}^2}$
Moment of inertia
$1\text{kg} \cdot \text{m}^2 = 1\text{W} \cdot \text{s}^3 = 1\text{Nm} \cdot \text{s}^2$
Acceleration due to gravity
$g = 9,80665 \frac{\text{m}}{\text{s}^2}$

Table A.4 Important units

A.2 Drive engineering equations

A.2.1 Basic physical equations

Translation	Rotation
Travel	Angle
$s = v \cdot t$	$\varphi = \omega \cdot t$
Velocity	
$v = \frac{s}{t}$	$v = \omega \cdot r = \frac{\pi \cdot n}{60} \cdot d$
Angular velocity	
	$\omega = \dot{\varphi} = \frac{2 \cdot \pi \cdot n}{60} = \frac{\varphi}{t}$
Acceleration	
$a = \frac{v}{t}$	$\dot{\omega} = \ddot{\varphi} = \frac{\omega}{t}$
Force	
$F = m \cdot a$	$F = m \cdot r \cdot \omega^2$
Torque	
$M = F \cdot r$	$M = J \cdot \dot{\omega}$
Power	
$P = F \cdot v$	$P = M \cdot \omega$
Energy	
$W = F \cdot s$	$W = M \cdot \varphi$
Energy	
$W = \frac{1}{2} \cdot m \cdot v^2$	$W = \frac{1}{2} \cdot J \cdot \omega^2$

Table A.5 Basic physical equations

A.2.2 Power

Rotational power	Rotational acceleration
$P = \frac{M \cdot n}{9,55}$	$P = \frac{J \cdot n^2}{91,2 \cdot t_{BE}}$
Translation/friction power	Translation/friction power with rise
$P = \frac{F \cdot v}{\eta} = \frac{m \cdot g \cdot \mu \cdot v}{\eta}$	$P = \frac{m \cdot g \cdot v}{\eta} \cdot (\mu \cdot \cos \alpha + \sin \alpha)$
Translation with acceleration	Lift
$P = \frac{m \cdot a \cdot v}{\eta}$	$P = \frac{m \cdot g \cdot v}{\eta}$

Table A.6 General drive capacity

a	Acceleration	m/s ²
F	Force	N
m	Mass	kg
M	Torque	Nm
n	Speed	rpm
P	Power	W
v	Velocity	m/s
η	Efficiency	
α	Angle of inclination	deg.
μ	Coefficient of friction	

Work output for metalworking machinery

Basic equation	
$P_s = \frac{F_H \cdot v_s}{60000}$	
Turning	
$P_s = \frac{F_H \cdot n_p \cdot 2 \cdot \pi \cdot r}{60000}$	
Milling	
$P_s = \frac{z_E \cdot F_m}{60000} \cdot v_s = \frac{z_E \cdot F_m}{60000} \cdot \frac{d \cdot \pi \cdot n_F}{1000}$	
Shearing and cutting	
$P_s = \frac{K_s \cdot l_s \cdot s \cdot v_s}{60000}$	
Drilling	
$P_s = \frac{z_E \cdot (d_1 - d_2) \cdot s_z \cdot K_s}{60000} \cdot v_s$	
Cutting speed during drilling	
$v_s = \frac{d_1 + d_2}{2} \cdot \frac{n_B \cdot \pi}{1000}$	
Pressing	
$P_P = \frac{F_{St} \cdot v_{St}}{60000}$	

Table A.7 Work output for metalworking machinery

b	Face width	mm
d	Cutter diameter	mm
d ₁	Drill diameter	mm
d ₂	Predrill diameter	mm
f	Advance per revolution	mm
F _H	Main cutting force	N
F _m	Mean cutting force in milling	N
F _{St}	Plunger force in pressing	N
K _S	Special cutting force (general)	N/mm ²
k _C	Specific cutting force for various cutting thicknesses	N/mm ²
k _{C11}	Specific cutting force for face cross-section 1 mm x 1 mm	N/mm ²
l _S	Length of cut line	mm
n _B	Drill speed	rpm
n _F	Cutter speed	rpm
n _P	Face plate speed	rpm

P_S	Cutting power	kW
P_P	Drive capacity of a press	kW
r	Turn radius	m
s	Sheet thickness	mm
s_Z	Advance per cutting edge	mm
v_S	Cutting speed	m/min
v_{St}	Plunger speed	m/min
z_E	Number of active cutting edges	
κ	Setting angle	deg.

1

2

3

4

5

6

A

Specific cutting forces of various metals

Material	Tensile strength in N/mm ² and hardness	k _{C11} in N/mm ²	k _C in N/mm ² at h in mm				
			h = f • sinK				
			0.063	0.1	0.16	0.25	0.4
St 34, St 37, St 44	500	1780	2820	2600	2400	2240	2060
St 50, C 35	520	1990	4200	3610	3190	2830	2500
St 60	620	2110	3310	3080	2830	2620	2440
St 70	720	2260	5120	4500	3920	3410	2990
C 45, Ck 45	670	2220	3240	3040	2840	2660	2500
C60, Ck60	770	2130	3430	3150	2920	2700	2490
16 Mn Cr 5	770	2100	4350	3830	3400	3020	2660
18 Cr Ni 6	630	2260	5140	4510	3920	3410	3000
42 Cr Mo 4	730	2500	5000	4500	4000	3550	3150
42 Cr Mo 4	600	2240	4000	3610	3200	3000	2750
50 Cr V 4	600	2220	4620	4100	3610	3290	2820
15 Cr Mo 5	590	2290	3660	3390	3130	2890	2680
55 Ni Cr Mo 6-G	940	1740	3470	3070	2720	2390	2170
55 Ni Cr Mo 6-V	1220	1920	3470	3310	2950	2860	2380
100 Cr 6-G	620	1730	3680	3320	2900	2560	2240
Mn, Cr Ni steels	850...1000	2350	4200	3800	3450	3150	2850
Cr, Mo & other alloy steels	1000...1400	2600	4450	4050	3700	3350	3100
Stainless steels	600...700	2550	4200	3850	3530	3250	3000
Mn hard steels		3300	6100	5500	4980	4500	4080
X 12 Cr Ni 18 8	HB 160	1600	3810	3480	2880	2500	2140
X 6 Cr Ni Mo 18 10	HB 163	1500	3930	3520	2960	2510	2110
GG 25	HB 200...250	1160	2360	2110	1870	1660	1470
GS 45	300...500	1600	2560	2360	2180	2000	1860
GTW 40, GTS 35	HB 220	1180	2240	2000	1800	1600	1460
Brass	HB 80...120	780	1300	1200	1100	1000	920
Cast bronze		1780	2870	2600	2400	2240	2060
Gunmetal		640	1250	1120	1000	900	800
Cast aluminium	300...420	640	1250	1120	1000	900	800

Table A.8 Specific cutting forces of various metals

Drive capacities in process engineering

- k_{C11} Specific basic cutting force for face cross-section 1 mm x 1 mm
- k_C Specific cutting force for various face thicknesses h

Drive capacities in process engineering	
Fan	
$P = \frac{Q_F \cdot p}{\eta}$	
Pump	
$P = \frac{Q_F \cdot p}{\eta}$	
Extruder	
$P = V \cdot \gamma$	

Table A.9 Drive capacities in process engineering

p	Total pressure	N/m ²
P	Drive capacity	kW
Q_F	Delivery	m ³ /s
V	Specified throughput	kg/h
γ	Specific drive power	kWh/kg
η	Fan efficiency/pump efficiency	

For fans:

- $\eta \approx 0.3$ at 1 kW
- $\eta \approx 0.5$ at 10 kW
- $\eta \approx 0.65$ at 100 kW

The following table shows the specific drive power for various thermoplasts:

Thermoplast	Specific drive power in kWh/kg
ABS	0.2 to 0.3
CAB	0.1 to 0.2
PA 6 and PA 66	0.2 to 0.4
PE - LD	0.2 to 0.25
PE - HD	0.25 to 0.3
PP	0.25 to 0.3
PVC	0.15 to 0.2

Table A.10 Specific drive power for various thermoplasts

A.2.3 Torques

Torques
Torque to produce translational movement
$M = \frac{F \cdot r}{1000} = 9,55 \cdot \frac{P}{n}$
Acceleration torque
$M_{BE} = J \cdot \dot{\omega} = J \cdot \frac{\dot{n}}{9,55} = J \cdot \frac{\Delta n}{9,55 \cdot t_{BE}}$
Acceleration time
$t_{BE} = J \cdot \frac{\Delta n}{9,55 \cdot (M - M_L)} = J \cdot \frac{(\Delta n)^2}{91,2 \cdot (P - P_L)}$

Table A.11 Torques

F	Circumferential force	N
J	Overall mass moment of inertia	kg · m ²
M	Motor torque	Nm
M _L	Load torque	Nm
n	Speed	rpm
P	Motor power	W
P _L	Power output of load	W
r	Radius of drive roller	mm
t _{BE}	Acceleration time	s
Δn	Differential speed	rpm
ω	Angular velocity	1/s

A.2.4 Work

Work of friction force
$W = F_R \cdot s = m \cdot g \cdot \mu_1 \cdot \cos\alpha \cdot s$
Work of acceleration force
$W = m \cdot \left(\frac{v_2^2}{2} - \frac{v_1^2}{2} \right)$
Work of gravity
$W = m \cdot g \cdot (h_2 - h_1)$
Work of spring force
$W = c \cdot \left(\frac{x_2^2}{2} - \frac{x_1^2}{2} \right)$
Work of friction torque
$W = M \cdot \mu_r \cdot \varphi$
Work of acceleration torque
$W = J \cdot \left(\frac{\varphi_2^2}{2} - \frac{\varphi_1^2}{2} \right) = J \cdot \left(\frac{\omega_2^2}{2} - \frac{\omega_1^2}{2} \right)$

Table A.12 Work

From these general equations, with $\omega_2 = \omega$ and $\omega_1 = 0$, with $v_2 = v$ and $v_1 = 0$, with $h_2 = h$ and $h_1 = 0$ and with $x_2 = x$ and $x_1 = 0$:

Kinetic energy of the translational movement
$W = \frac{1}{2} \cdot m \cdot v^2$
Kinetic energy of the rotational movement
$W = \frac{1}{2} \cdot J \cdot \omega^2$
Potential energy of the position
$W = m \cdot g \cdot h$
Potential energy of the fields
$W = \frac{1}{2} \cdot c \cdot x^2$

Table A.13 Energy

c	Spring rigidity	Nm
F_R	Friction force	N
g	Acceleration due to gravity	m/s ²
h	Lift height	m
h_1	Lift height at time $t=t_1$	m
h_2	Lift height at time $t=t_2$	m
J	Mass moment of inertia	kg · m ²
m	Mass	kg
M	Torque	Nm
M_R	Friction torque	Nm
s	Effective travel of friction force	m
v	Velocity	m/s
v_1	Velocity at time $t=t_1$	m/s
v_2	Velocity at time $t=t_2$	m/s
W	Work	Nm
x	Spring travel	m
x_1	Spring travel at time $t=t_1$	m
x_2	Spring travel at time $t=t_2$	m
α	Angle of inclination of inclined plane	deg
μ_1	Coefficient of friction for longitudinal movement	
μ_r	Coefficient of friction for rotational movement	
φ_1	Angle of revolution at time $t=t_1$	rad
φ_2	Angle of revolution at time $t=t_2$	rad
ω	Angular velocity	1/s
ω_1	Angular velocity at time $t=t_1$	1/s
ω_2	Angular velocity at time $t=t_2$	1/s

A.2.5 Friction

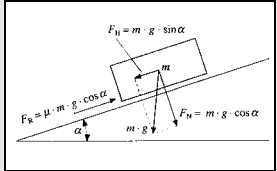
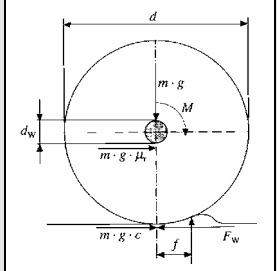
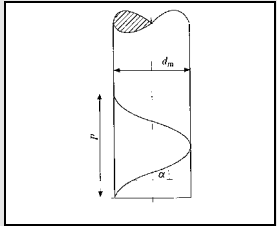
<p>Friction force of Coulomb friction (dry friction)</p> $F_R = F_N \cdot \mu_l = m \cdot g \cdot \mu_l \cdot \cos \alpha$	
<p>Tractive resistance to rolling friction</p> $F_W = m \cdot g \cdot \left[\frac{2}{d} \cdot \left(\frac{d_W}{2} \cdot \mu_r + f \right) + c \right]$	
<p>Friction torque in thread</p> $M_R = F \cdot \frac{d_m}{2} \cdot \tan \rho$	

Table A.14 Friction

c	Rim friction	
d	Wheel diameter	m
d _m	Mean thread diameter	m
d _w	Axle/shaft diameter	m
F	Longitudinal force in screw/ threaded spindle N	
F _N	Normal force	N
F _R	Friction force with Coulomb friction	N
F _W	Tractive resistance to rolling friction	N
f	Lever arm of rolling friction	m
g	Acceleration due to gravity	m/s ²
m	Mass	kg
M _R	Friction torque	Nm
α	Angle of inclination of inclined plane	deg.
μ _l	Coefficient of friction in longitudinal movement	
μ _r	Coefficient of friction in rotational movement	
ρ	Friction angle in threaded spindles	deg.

A.2.6 Effective motor torque/power output

$$M_{\text{eff}} = \sqrt{\frac{1}{T} \cdot \sum_{i=1}^n M_i^2 \cdot t_i}$$

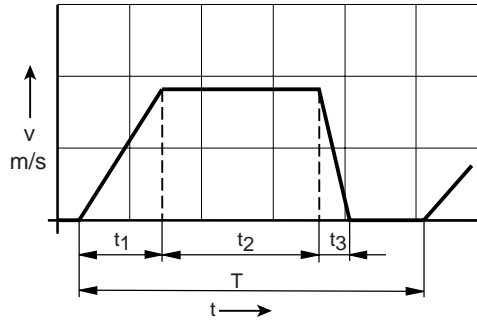
$$M_{\text{eff}} = \sqrt{\frac{M_1^2 \cdot t_1 + M_2^2 \cdot t_2 + M_3^2 \cdot t_3}{T}}$$

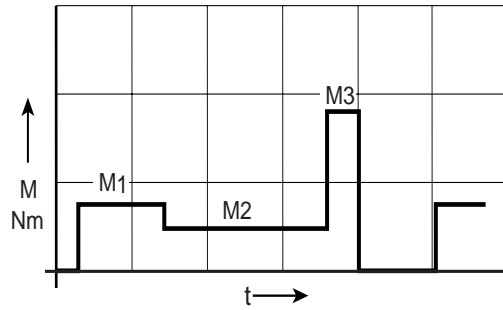
$$P_{\text{eff}} = \sqrt{\frac{1}{T} \cdot \sum_{i=1}^n P_i^2 \cdot t_i}$$

$$P_{\text{eff}} = \sqrt{\frac{P_1^2 \cdot t_1 + P_2^2 \cdot t_2 + P_3^2 \cdot t_3}{T}}$$

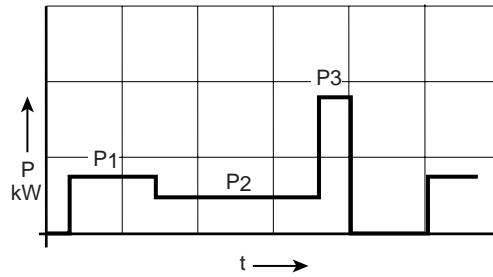
Table A.15 Effective motor torque/power output

The following diagrams relating to a working example illustrate the meanings of the formula symbols used.





Rating: The motor is defined at $M_N \geq M_{\text{eff}}$.



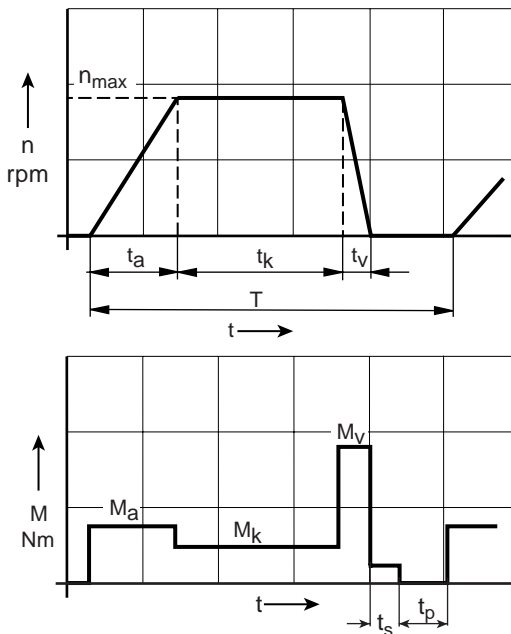
Rating: The motor is defined at $P_N \geq P_{\text{eff}}$.

Effective value method for internally cooled standard three-phase AC motors

The following load cycle is assumed in describing the effective value method for internally cooled standard three-phase AC motors.

Practical tip:

If $n_{max} <$ motor nominal speed, the load cycle must be tested by the motor manufacturer.



Effective torque

$$M_{eff} = \sqrt{\frac{M_a^2 \cdot t_a + M_k^2 \cdot t_k + M_v^2 \cdot t_v + M_s^2 \cdot t_s}{K_1 \cdot (t_a + t_v) + t_k + K_2 \cdot t_s + t_p}}$$

Typical reduction factors for internally cooled motors

$K_1 =$ approx. 0.7 Reduction factor for acceleration and deceleration processes of standard three-phase AC motors ≤ 2.2 kW
 approx. 0.6 Reduction factor for acceleration and deceleration processes of standard three-phase AC motors > 2.2 kW

$K_2 =$ approx. 0.3 Reduction factor for standstill torque (only in FOR mode)

Rating: The internally cooled motor is defined at $M_N \geq M_{eff}$.
 The rule only applies where $n_{max} \geq$ motor nominal speed.

A.2.7 Choice of max. acceleration

Slip of a conveyed item

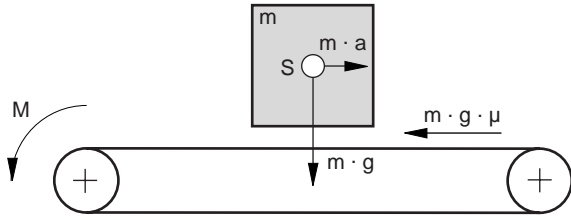


Figure A.1 Conveyor belt with unsecured object during acceleration

Maximum acceleration: $a = g \cdot \mu$

- a Belt acceleration in m/s²
- g Acceleration due to gravity in m/s²
- μ Coefficient of friction

Stability limit of a conveyed item

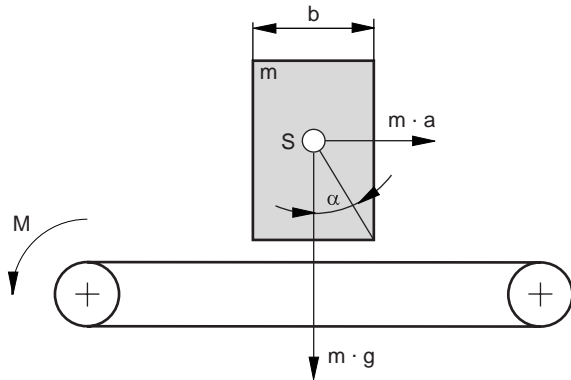


Figure 1.2 Conveyor belt with a high body and small standing area

Maximum acceleration: $a \leq \frac{b}{h} \cdot g$

- a Belt acceleration in m/s²
- b Width of body in m
- g Acceleration due to gravity in m/s²
- h Height of body in m

Overswill of a liquid

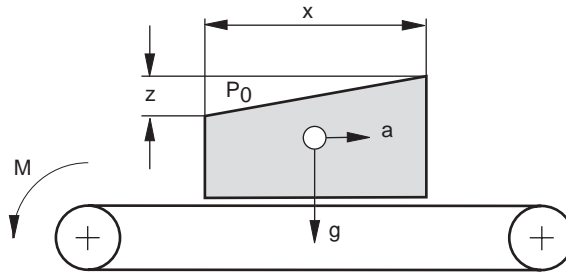


Figure 1.3 Conveyor belt in acceleration phase with a vessel filled with liquid

Height difference during acceleration:

$$z = \frac{a}{g} \cdot x$$

The value z indicates the height difference of the liquid level in a vessel of length x accelerated at speed a . At the point of the lowest liquid level z is always 0.

- a Belt acceleration in m/s^2
- g Acceleration due to gravity in m/s^2
- x Coordinates in horizontal direction in m
- z Coordinates in vertical direction in m

Pendulum of a suspended load

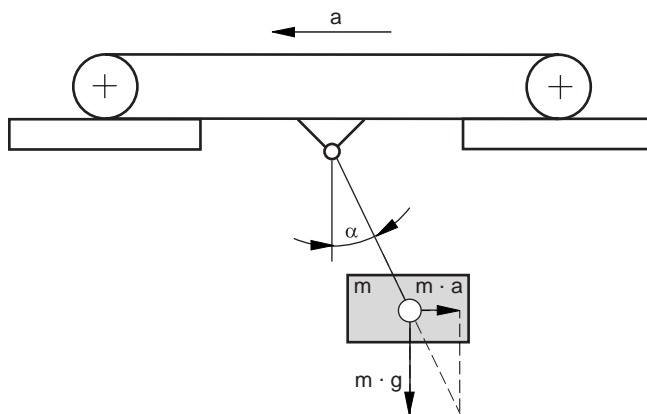


Figure 1.4 Schematic view of a crane with suspended load

Maximum acceleration: $a = g \cdot \tan \alpha$

a Belt acceleration in m/s^2

g Acceleration due to gravity in m/s^2

α Angle of deflection of cable in degrees.



In most applications the angle α should not exceed a value of 3° . With this value the result for the acceleration is:

A.2.8 Mass moments of inertia

Mass moments of inertia of bodies

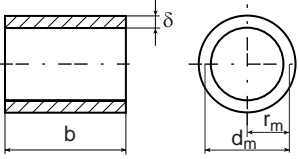
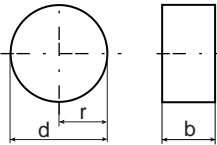
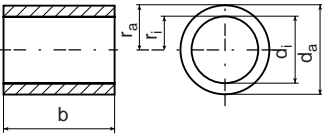
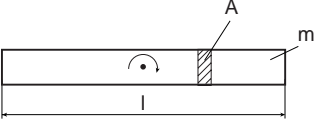
<p>Thin-walled hollow cylinder</p> $J = m \cdot \frac{d_m}{4} = \frac{d_m^3}{4} \cdot \pi \cdot b \cdot \rho \cdot \delta$	
<p>Cylinder with full circular cross-section</p> $J = \frac{m}{2} \cdot \left(\frac{d}{2}\right)^2 = \frac{\pi \cdot b \cdot \rho}{2} \cdot \left(\frac{d}{2}\right)^4$	
<p>Thick-walled hollow cylinder</p> $J = \frac{m}{2} \left[\left(\frac{d_a}{2}\right)^2 + \left(\frac{d_i}{2}\right)^2 \right]$	
<p>Long, thin bar with pivot point at centre of gravity</p> $J = \frac{m}{12} \cdot l^2 = \frac{A \cdot \rho}{12} \cdot l^3$	

Table A.16 Mass moments of inertia of bodies

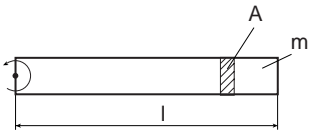
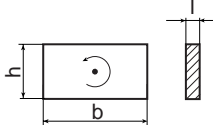
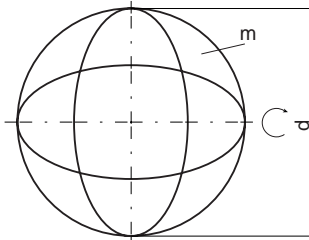
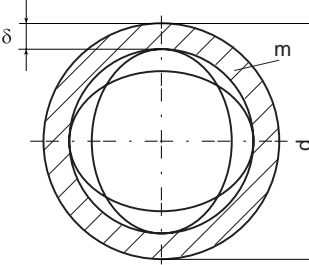
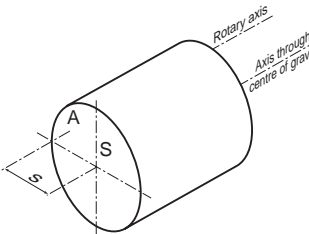
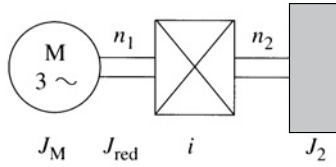
<p>Long, thin bar with pivot point at end of bar</p> $J = \frac{m}{3} \cdot l^2 = \frac{A \cdot \rho}{3} \cdot l^3$	
<p>Rectangular plate with pivot point at centre of gravity</p> $J = \frac{m}{12} \cdot (h^2 + b^2)$	
<p>Solid ball with rotary axis through centre of gravity</p> $J = \frac{2 \cdot m}{5} \cdot \left(\frac{d}{2}\right)^2 = \frac{\pi \cdot \rho \cdot d^5}{60}$	
<p>Thin-walled ball shell with rotary axis through centre of gravity</p> $J = \frac{2 \cdot m}{3} \cdot \left(\frac{d}{2}\right)^2 = \frac{\pi \cdot \rho \cdot \delta \cdot d^4}{6}$	
<p>Steiner's law</p> $J_A = J_S + m \cdot s^2$	

Table A.16 Mass moments of inertia of bodies

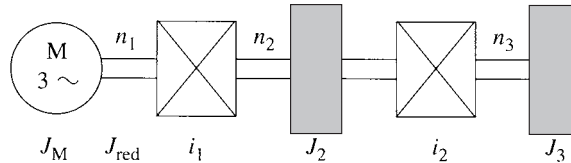
Reduction via one gear



$$J_{\text{red}} = \frac{J_2}{(i)^2} = \frac{J_2}{(n_1/n_2)^2}$$

$$J_{\text{tot}} = J_M + J_{\text{red}}$$

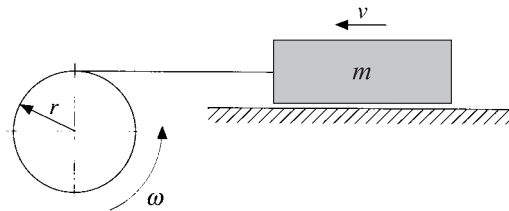
Reduction via two gears



$$J_{\text{red}} = \frac{J_2 + \frac{J_3}{(i_2)^2}}{(i_1)^2} = \frac{J_2 + \frac{J_3}{(n_2/n_3)^2}}{(n_1/n_2)^2}$$

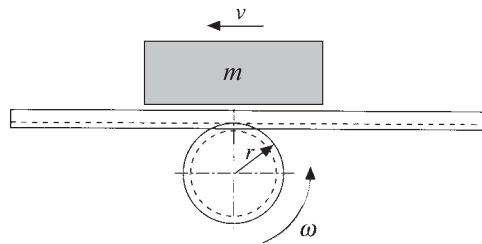
$$J_{\text{tot}} = J_M + J_{\text{red}}$$

Movement by conveyor roller



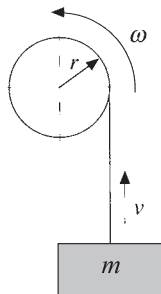
$$J = m \cdot r^2 = m \cdot \left(\frac{v}{\omega}\right)^2 = m \cdot \left(\frac{60 \cdot v}{2 \cdot \pi \cdot n}\right)^2$$

Movement by rack



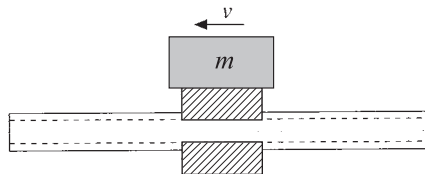
$$J = m \cdot r^2 = m \cdot \left(\frac{v}{\omega}\right)^2 = m \cdot \left(\frac{60 \cdot v}{2 \cdot \pi \cdot n}\right)^2$$

Movement by cable reel



$$J = m \cdot r^2 = m \cdot \left(\frac{v}{\omega}\right)^2 = m \cdot \left(\frac{60 \cdot v}{2 \cdot \pi \cdot n}\right)^2$$

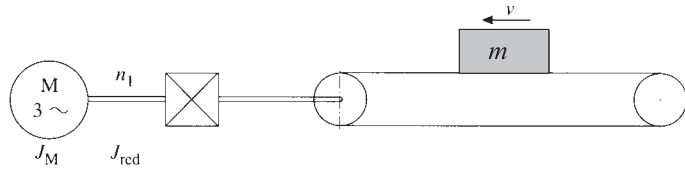
Movement by spindle



$$J = m \cdot \left(\frac{P}{2 \cdot \pi}\right)^2$$

P Lead in thread

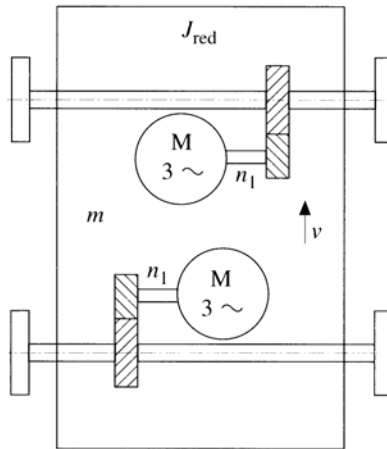
Conversion from translation into rotation



$$J_{\text{red}} = 91,2 \cdot m \cdot \left(\frac{v}{n_1}\right)^2$$

$$J_{\text{tot}} = J_M + J_{\text{red}}$$

Conversion from translation into rotation with several motors

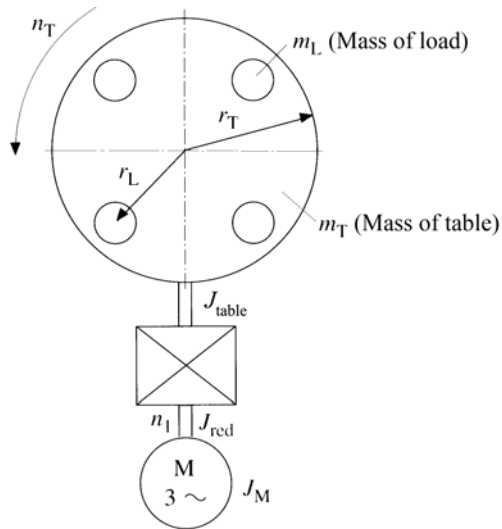


$$J_{\text{red}} = \frac{1}{k_A} \cdot 91,2 \cdot m \cdot \left(\frac{v}{n_1}\right)^2$$

k_A Number of drives

$$J_{\text{tot}} = J_M \cdot k_A + J_{\text{red}}$$

Indexing table with eccentric loads



$$J_{table} = \frac{1}{2} \cdot m_T \cdot r_T + m_L \cdot r_L$$

$$J_{red} = J_{table} \cdot \left(\frac{n_T}{n_1} \right)^2$$

$$J_{tot} = J_M + J_{red}$$

A.2.9 Optimum transmission ratio

Optimum transmission ratio for shortest acceleration time at constant motor torque.

Centrifugal-load drive without friction: $M_{\text{Load}} = 0$; $\eta = 1$

$$i_{\text{opt}} = \sqrt{\frac{I_{\text{Load}}}{I_{\text{Motor}}}} \quad \text{or} \quad I_{\text{Motor}} = \frac{I_{\text{Load}}}{i_{\text{opt}}^2}$$

Start-up against load and friction: $M_{\text{Load}} > 0$; $\eta < 1$

$$i_{\text{opt}} = \frac{M_{\text{Load}}}{M_{\text{Motor}}} + \sqrt{\left(\frac{M_{\text{Load}}}{M_{\text{Motor}}}\right)^2} + \frac{I_{\text{Load}}}{I_{\text{Motor}}}$$

A.2.10 v/t diagram

Acceleration time

$$t_{BE} = \frac{v}{a_{BE}}$$

Acceleration travel

$$s_{BE} = \frac{1}{2} \cdot v \cdot t_{BE} = \frac{1}{2} \cdot a_{BE} \cdot t_{BE}^2$$

Braking time

$$t_{BR} = \frac{v}{a_{BR}}$$

Braking travel

$$s_{BR} = \frac{1}{2} \cdot v \cdot t_{BR} = \frac{1}{2} \cdot a_{BR} \cdot t_{BR}^2$$

Travel with v=const.

$$s = v \cdot t$$

Time for v=const.

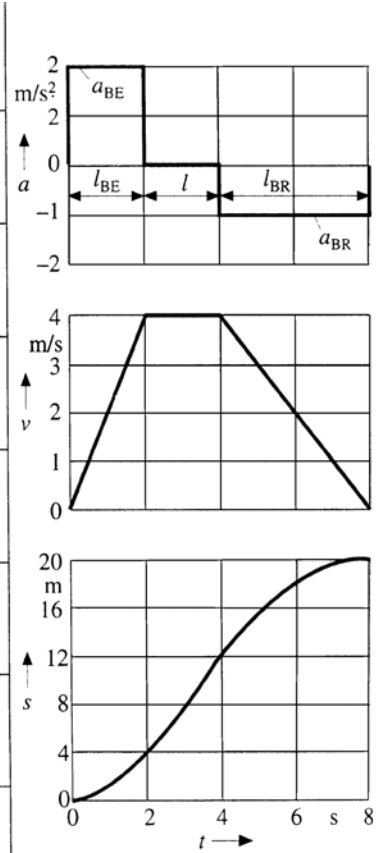
$$t = \frac{s}{v}$$

Total travel

$$s_{tot} = s_{BE} + s_{BR} + s$$

Total time

$$t_{tot} = t_{BE} + t_{BR} + t$$



v/t diagram for minimum torque

Acceleration time

$$t_{BE} = \frac{v}{a_{BE}}$$

Acceleration travel

$$s_{BE} = \frac{1}{2} \cdot v \cdot t_{BE} = \frac{1}{2} \cdot a_{BE} \cdot t_{BE}^2$$

Braking time

$$t_{BR} = \frac{v}{a_{BR}}$$

Braking travel

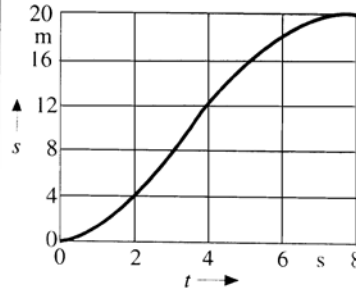
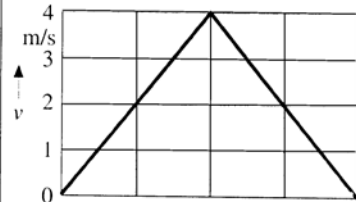
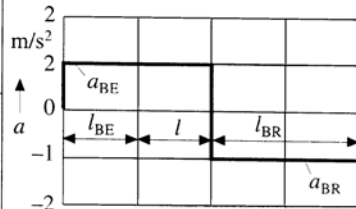
$$s_{BR} = \frac{1}{2} \cdot v \cdot t_{BR} = \frac{1}{2} \cdot a_{BR} \cdot t_{BR}^2$$

Total travel

$$s_{tot} = s_{BE} + s_{BR}$$

Total time

$$t_{tot} = t_{BE} + t_{BR}$$



v/t diagram with sinusoidal characteristic

Period

$$T = 2 \cdot \pi \cdot \frac{v_{\max}}{a_{\max}}$$

Acceleration time

$$t_{\text{BE}} = \frac{T}{4}$$

Acceleration travel

$$s_{\text{BE}} = v_{\max} \cdot \frac{T}{8}$$

Braking time

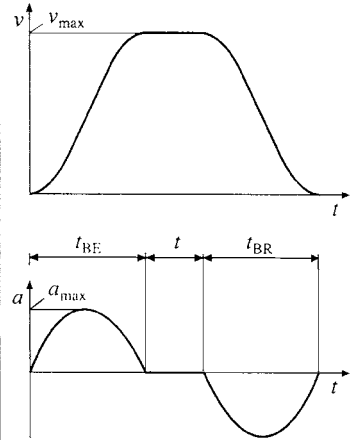
$$t_{\text{BR}} = \frac{T}{4}$$

Braking travel

$$s_{\text{BR}} = v_{\max} \cdot \frac{T}{8}$$

Acceleration

$$a_{\max} = \frac{2 \cdot \pi \cdot v_{\max}}{T} = \frac{1.57 \cdot v_{\max}}{t_{\text{BE}}}$$



A.2.11 Efficiencies, coefficients of friction and density

Efficiencies of transmission elements

Transmission element	Characteristic	Efficiency
Wire cable	Each complete wrap of the cable reel (friction or roller bearing supported)	$\eta = 0.91 - 0.95$
V-belt	Each complete wrap of the V-belt pulley (normal belt tension)	$\eta = 0.88 - 0.93$
Plastic belts	Each complete wrap; rollers on roller bearings (normal belt tension)	$\eta = 0.81 - 0.85$
Rubber belts	Each complete wrap; rollers on roller bearings (normal belt tension)	$\eta = 0.81 - 0.85$
Chains	Each complete wrap; chains on roller bearings (depending on chain size)	$\eta = 0.90 - 0.96$
Spindles	Trapezoidal threaded spindle Recirculating ball spindle	$\eta = 0.30 - 0.70$ $\eta = 0.70 - 0.95$

Table A.17 Efficiencies of transmission elements

Coefficients of friction for bearing friction

Bearing type	Coefficient of friction
Roller bearing	$\mu = 0.001$ to 0.005
Friction bearing	$\mu = 0.08$ - 0.1

Table A.18 Coefficients of friction for bearing friction

Coefficients of friction for roller bearing friction

Roller bearing	Coefficient of friction
Axial groove ball bearing	0.0013
Radial self-aligning ball bearing	0.0010
Radial self-aligning roller bearing	0.0018
Radial groove ball bearing	0.0015
Radial taper roller bearing	0.0018
Radial cylinder roller bearing	0.0011
Radial needle bearing	0.0045

Table A.19 Coefficients of friction for roller bearing friction

Coefficients of friction for spindles

Spindle type	Coefficient of friction
Trapezoidal threaded spindle	$\mu = 0.05$ - 0.08 (greased) $\mu = 0.1$ - 0.18 (dry)
Recirculating ball spindle	$\mu = 0.005$ - 0.05

Table A.20 Coefficients of friction for spindles

Coefficients for rim and side friction

Wheel type	Coefficients for rim and side friction
Roller bearing supported wheels	$c = 0.003$
Friction bearing supported wheels	$c = 0.005$
Side guide rollers	$c = 0.002$

Table A.21 Coefficients for rim and side friction

Coefficients of friction of various material pairings

Friction pairing	Friction type	Coefficient of friction
Steel on steel	Static friction (dry)	$\mu_0=0.12-0.60$
	Sliding friction (dry)	$\mu =0.08-0.50$
	Static friction (greased)	$\mu_0=0.12-0.35$
	Sliding friction (greased)	$\mu =0.04-0.25$
Wood on steel	Static friction (dry)	$\mu_0=0.45-0.75$
	Sliding friction (dry)	$\mu =0.30-0.60$
Wood on wood	Static friction (dry)	$\mu_0=0.40-0.75$
	Sliding friction (dry)	$\mu =0.30-0.50$
Plastic belt on steel	Static friction (dry)	$\mu_0=0.25-0.45$
	Sliding friction (dry)	$\mu =0.25$
Steel on plastic	Static friction (dry)	$\mu_0=0.20-0.45$
	Sliding friction (dry)	$\mu =0.18-0.35$

Table A.22 Coefficients of friction of various material pairings

Lever arm of rolling friction for various material pairings

Material pairing	Lever arm of rolling friction
Steel on steel	$f=0.5$ mm
Wood on steel (roller conveyor)	$f=1.2$ mm
Plastic on steel	$f=2.0$ mm
Hard rubber on steel	$f=7.0$ mm
Plastic on concrete	$f=5.0$ mm
Hard rubber on concrete	$f=10$ mm - 20 mm
Medium-hard rubber on concrete	$f=15$ mm - 35 mm

Table A.23 Lever arm of rolling friction for various material pairings

Density ρ of various materials

Aluminium	2700	kg/m ³
Grey-cast metal	7600	kg/m ³
Copper	8960	kg/m ³
Brass	8400-8900	kg/m ³
Steel	7860	kg/m ³
Zinc	7130	kg/m ³
Tin	7290	kg/m ³

Table A.24 Density of various materials

Epoxy resin	1200	kg/m ³
Rubber	920-990	kg/m ³
Phenol resin, type 31	1400	kg/m ³
Polyethylene	900-950	kg/m ³
PVC	1300-1400	kg/m ³

Table A.24 Density of various materials

A.2.12 Definitions of lateral forces

The expected lateral forces must be calculated in order to determine the correct size of motor and gearing.

Transmission elements	Comments	Supplement f_z
Gear wheels	≥ 17 cogs < 17 cogs	1 1.15
Chain wheels	≥ 20 cogs < 20 cogs < 13 cogs	1 1.25 1.4
Narrow V-belt pulley	Dependent on pre-tension	1.5-2
Flat belt with tension roller	Dependent on pre-tension	2-2.5
Flat belt without tension roller	Dependent on pre-tension	2.3-3

Table A.25 *Lateral forces*

$$F_Q = (M/r) \cdot f_z$$

M Torque

r Radius

f_z Supplement for radial force calculation

A.2.13 Autotransformer

Autotransformers have common input and output windings. There is therefore no electrical isolation between the windings. Depending on the voltage transformation, an in-part substantial "reduction in core power" (nominal power) relative to an isolating transformer results.

$$S_b = S_a \cdot \frac{U_o - U_u}{U_o} = [\text{kVA}]$$

S_b = Nominal power in kVA

S_a = Acceptance power in kVA

U_u = Lowest voltage (output voltage)

U_o = Highest voltage (input voltage)



The nominal power is the power which the magnetic core must transmit as a transformer with a separate winding.

A.2.14 Line choke

Short-circuit voltage

$$U_K = \frac{\Delta_u \cdot 100 \cdot \sqrt{3}}{U_N} \text{ in \%}$$

Δ_u Voltage dip per choke phase [V]

U_N Rated voltage [V]

U_K Short-circuit voltage in [%]

Inductance per choke phase

$$L = \frac{\Delta_u}{I_{LN} \cdot \omega} = \frac{\Delta_u}{I_N \cdot 2 \cdot \pi \cdot f} \text{ [mH]}$$

I_{LN} Rated current per phase [A]

f Mains frequency 50/60 Hz

Inductive resistance

$$X_L = 2 \cdot \pi \cdot f \cdot L = [\Omega \text{ per phase}]$$

A.3 Drive controller

A.3.1 Voltage Frequency Control (VFC)

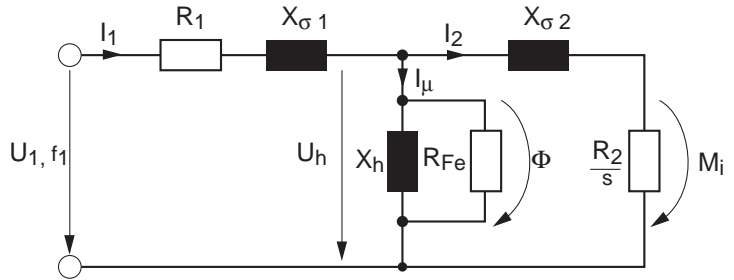


Figure 1.5 Stationary equivalent circuit diagram of the asynchronous machine

Synchronous speed
$n_s = \frac{60 \cdot f_1}{p}$
Inner moment of the motor
$M_i \sim \Phi \cdot I_2$
Magnetic flux
$\Phi \sim I_\mu \sim \frac{U_h}{2 \cdot \pi \cdot f_1 \cdot L_h}$
Basic setting range (rule 1)
$\beta \frac{U_1}{f_1} = \text{const. } \beta \Phi \approx \text{const. } \beta M_i \approx \text{const.}$
Field weakening (rule 2)
$\beta \left(\begin{array}{l} U_1 = \text{konstant} \\ f_1 = \text{veränderlich} \end{array} \right) \beta \Phi \approx \frac{1}{f_1} \text{ const. } \beta M_i \approx \frac{1}{f_1} \text{ const.}$

Table A.26 Basic equations and rules

Voltage rise to compensate for the ohmic voltage dip

- Assuming rated current (for constant rated torque) throughout the frequency range up to the nominal point (50Hz), the absolute value of the ohmic voltage dip at R_1 (stator resistor) remains constant.
- The relative voltage dip at R_1 , measured at U_1 , rises as the frequency decreases.
 - To compensate for the voltage dip at the stator resistor R_1 the feed voltage U_1 (boost) is increased in the lower frequency range.

Numeric example for a 0.37 kW motor:

0.37 kW, 220 V Δ , 2.05 A, phase resistance = $P_{Ph} = 24 \Omega$

- Ohmic voltage dip

$$\begin{aligned}\Delta U &= R_1 \cdot I_1 \\ &= \frac{24 \cdot 2.05}{\sqrt{3}} = 28 \text{ V}\end{aligned}$$

- If the voltage is adjusted in linear mode with the frequency, at 5 Hz connected to the motor terminals is:

$$U_{5 \text{ Hz}} = \frac{220 \text{ V} \cdot 5 \text{ Hz}}{50 \text{ Hz}} = 22 \text{ V}$$

- This is too little to form the nominal flux!
- The voltage must be increased by over the linear ratio V/F.

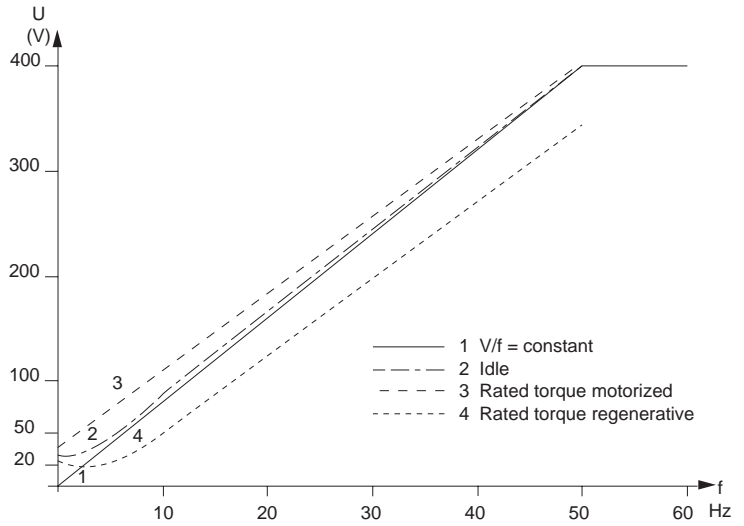


Figure 1.6 V/F characteristic in different load states



The specimen application is only intended to demonstrate that a manual boost setting no longer represents the state of the art.

Motor control method

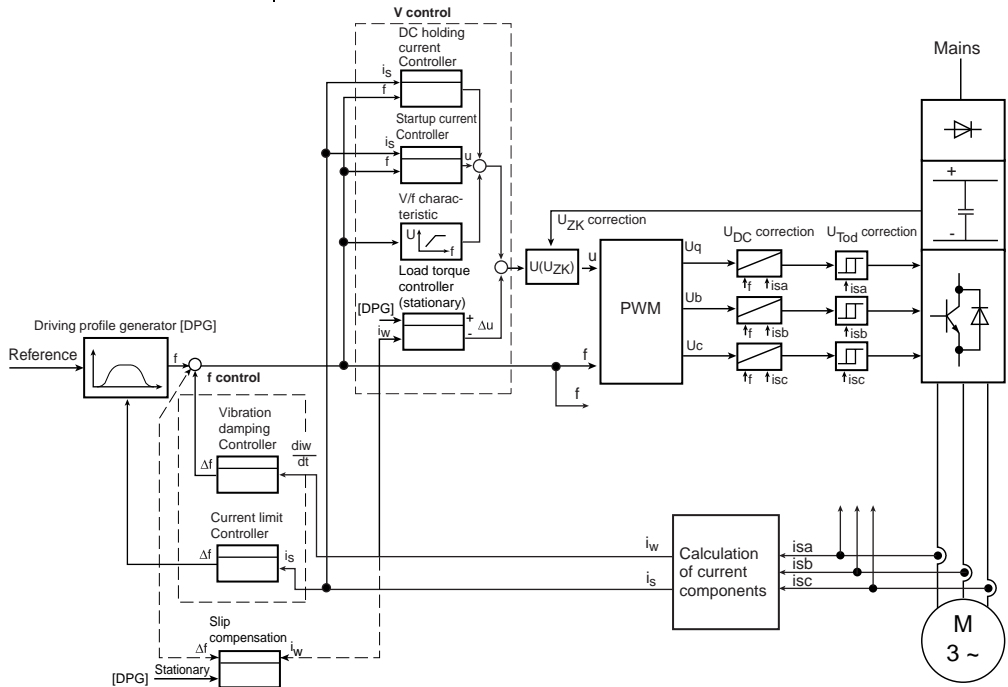


Figure 1.7 Block diagram of control circuit

Closed-loop control function	Advantage	Limits
Controller start-up current	<ul style="list-style-type: none"> - Automatic adaptation of the start-up current and the typical boost voltage - Start-up possible in all load situations 	<ul style="list-style-type: none"> - Pay attention to thermal heat-up of motor
Load torque controller	<ul style="list-style-type: none"> - Automatic adaptation of V/F characteristic in stationary operation - Low motor heat-up - Higher torque output possible 	<ul style="list-style-type: none"> - Only works in stationary mode, and delivers no particular improvement in dynamics
Controller current limit	<ul style="list-style-type: none"> - Heavy-duty start-up with automatic adaptation of acceleration ramp - Protection against current overload shut-off - Prevents stalling of the motor in stationary operation by reducing the stator frequency 	<ul style="list-style-type: none"> - Only works with a constant or falling load torque characteristic
Vibration damping controller	<ul style="list-style-type: none"> - Motors with bend-critical rotor shafts - The closed-loop control function additionally has a damping effect in acceleration processes with mechanisms which generate major elasticity and/or slack 	<ul style="list-style-type: none"> - Not known
Slip compensation	<ul style="list-style-type: none"> - Reduction of speed fluctuation of an asynchronous machine to around 2 % 	<ul style="list-style-type: none"> - The accuracy is dependent on the motor temperature - The function is in most cases implemented by SFC motor control

Table A.27 Closed-loop control functions of the drive controller with the VFC motor control method

A.3.2 Basic principle of Sensorless Flux Control (SFC)

Not available at time of going to press.

A.3.3 Torque formation of synchronous and asynchronous motors

Simplified principle of function of the DC machine

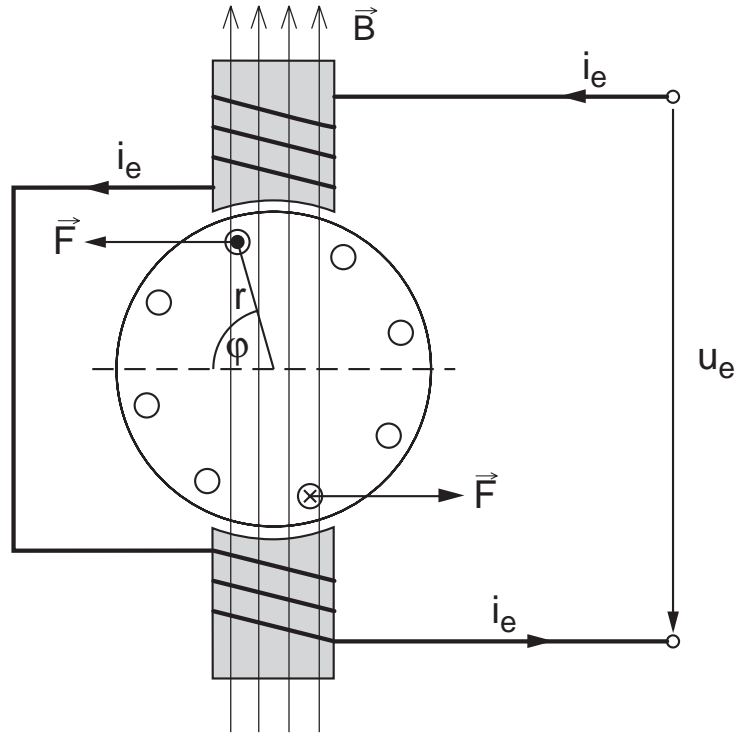


Figure 1.8 Simplified principle of function of the DC machine

- Field position preset by position of stator winding.
- The armature current is always injected by the commutator precisely where the field is the largest.

$$\left. \begin{array}{l} F \sim i_{sq} \cdot \Phi \\ M = F \cdot r \end{array} \right\} \rightarrow M = i_{sq} \cdot \Phi \cdot r, \quad \begin{array}{l} \Phi = \text{const.} \\ r = \text{const.} \end{array}$$

- The design of the commutator means the DC machine is always optimally fed - that is, field-oriented.



In a DC machine the wear-susceptible commutator limits the dynamics, the maximum speed and the maximum torque at low speeds.

Simplified principle of function of the permanently excited synchronous machine

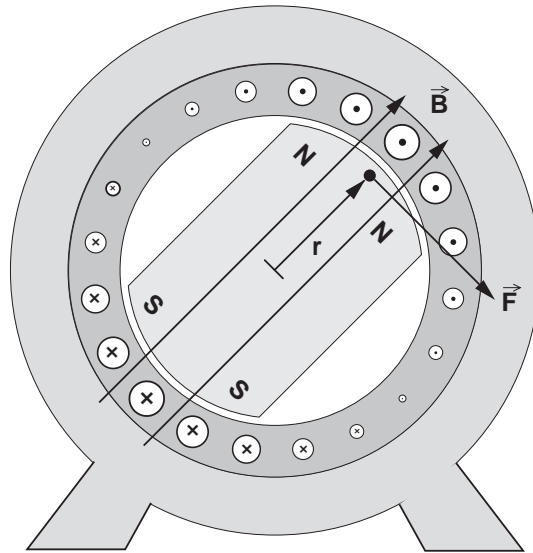


Figure 1.9 Simplified principle of function of the permanently excited synchronous machine

- Avoidance of commutator by reversing the principle.
- The field position in the rotor is known by the position encoder.
- The torque-forming current is injected by way of the stator precisely where the field is the largest.

$$\left. \begin{array}{l} F \sim i_{sq} \cdot \Phi \\ M = F \cdot r \end{array} \right\} \rightarrow M = i_{sq} \cdot \Phi \cdot r, \quad \begin{array}{l} \Phi = \text{const.} \\ r = \text{const.} \end{array}$$

- The position encoder on the rotor means the torque-forming current is always optimally fed - that is, field-oriented.

Simplified principle of function of the asynchronous machine

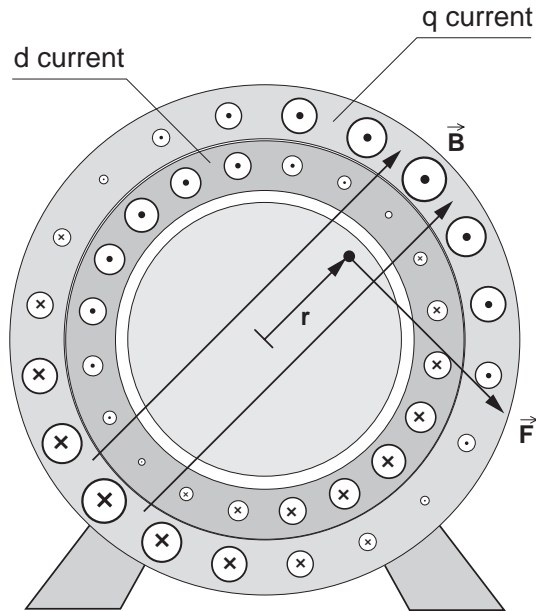


Figure 1.10 Simplified principle of function of the asynchronous machine

- The field in the rotor is built up by the stator currents (inner shell).
- The field position in the rotor is calculated using a machine model in the controller. For this, the phase currents and the rotor speed must be known.
- The torque-forming current (outer shell) is injected precisely where the field is the largest.

$$\left. \begin{array}{l} F \sim i_{sq} \cdot \Phi \\ M = F \cdot r \end{array} \right\} \rightarrow M = i_{sq} \cdot \Phi \cdot r, \quad \begin{array}{l} \Phi = \text{const.} \\ r = \text{const.} \end{array}$$

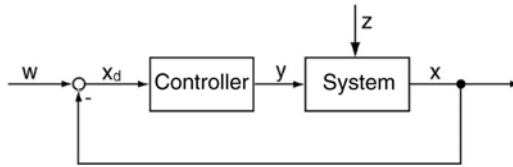
$\Phi = \text{const.}$ in basic setting range

- The machine model means the torque-forming current is always optimally fed - that is, field-oriented.

A.3.4 Basics of closed-loop control

The control loop - "Functions of the control loop"

- Adjust output variable to reference value
- Correct disturbance



- w: Reference input variable
 x_d : Control difference, $x_d = w - x$
 y: Manipulated variable
 x: Controlled variable
 z: Disturbance

The controlled system

The controlled systems are not classified by the physical quantities being controlled, but by their behaviour over time.

The behaviour over time of a controlled system is most easily identified when the input variable is suddenly changed while observing the output variable.

The P element controlled system

The P element is the simplest kind of controlled system. Between the output and input variables there is a proportional correlation:

$$x = K * y \quad K: \text{Proportionality factor, gain}$$

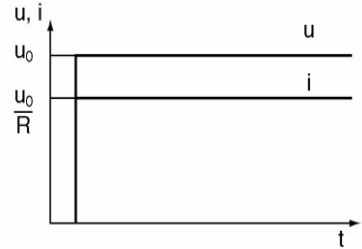
Example:

The current is at all times proportional to the voltage u:

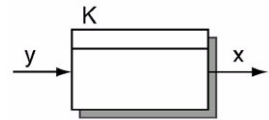
$$i = \frac{1}{R} * u \quad \rightarrow \quad K = \frac{1}{R}$$

The P element controlled system

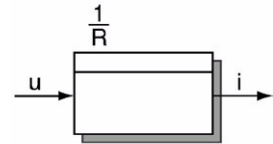
Step response



P element symbol



Symbol for example

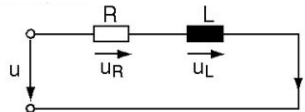


The PT1 element controlled system

Most controlled systems respond at more or less of a delay to a stepped input signal. This indicates the presence of one or more energy accumulators. A PT1 element has an accumulator and can be described by the differential equation:

$$x + T \frac{dx}{dt} = K y$$

Example:



$$u = u_R + u_L$$

$$u = R \cdot i + L \frac{di}{dt}$$

$$i + \frac{L}{R} \frac{di}{dt} = \frac{1}{R} \cdot u$$

$$\frac{1}{R} : \text{ Gain}$$

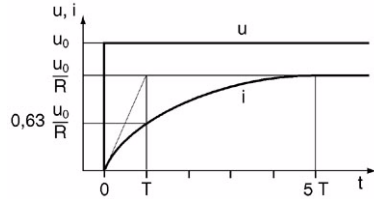
$$\frac{L}{R} = T : \text{ Time constant}$$

T is the coefficient (multiplier) of the 1st derivation of the output variable and is a measure of the 1st order delay.

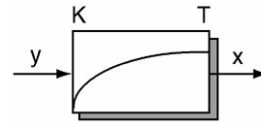
The PT1 element controlled system

Step response

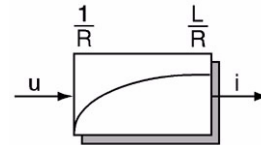
$$i = \frac{u}{R} * (1 - e^{-\frac{t}{T}})$$



PT1 element symbol



Symbol for example



After the time $t=5T$ i has reached approximately 99 % of its final value. It is said that the transient response is then ended.

The I element controlled system

In the controlled systems with P response dealt with so far the key feature is that the output variable strives to reach a new fixed final value following a step change in the input variable.

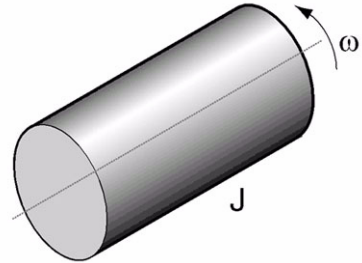
The I element exhibits an entirely different behaviour. Here the proportionality exists between the rate of change of the output variable and the value of the input variable:

$$\frac{dx}{dt} = K_I * y$$

Example:

Run-up of a motor of moment of inertia J from a standstill with the drive torque m_a Without load ($m_L = 0$), general form of movement equation.

$$J \frac{d\omega}{dt} = m_a - m_L$$



$$J \frac{d\omega}{dt} = m_a - m_L, \quad m_L = 0$$

$$J \frac{d\omega}{dt} = m_a$$

$$J \int \frac{d\omega}{dt} dt = \int m_a dt + c$$

$$J\omega = \int m_a dt + c$$

Run-up from standstill $\rightarrow \omega(t=0) = 0 \Rightarrow c = 0$

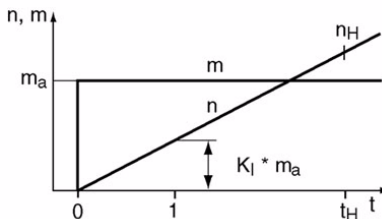
$$\omega = \frac{1}{J} \int m_a dt, \quad \omega = \frac{2\pi n}{60}$$

$$n = \frac{60}{2\pi J} \int m_a dt$$

$$\frac{60}{2\pi J} = K_I: \text{Integration coefficient}$$

The I element controlled system

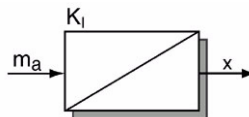
Step response



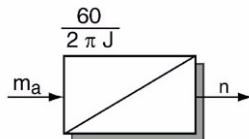
The time for a run-up from $n=0$ to $n=n_H$ is:

$$t_H = \frac{dx}{K_I * m_a}$$

I element symbol



Symbol for example



Controller

The function of a controller is to continually compare the controlled variable x against a preset fixed or variable reference value w and to influence the controlled system such that the control difference x_d becomes zero or as small as possible.

Like the controlled systems, the controllers are also differentiated according to their behaviour over time.

Basic controller types:

- Proportional-action controller (P controller)
- Integral-action controller (I controller)
- Differential-action controller (D controller)

The differential action is the only working principle which is unsuitable for a controller, as it only responds to changes in the control difference x_d . Therefore it can only be used as a supplement to the two other controller types.

In drive engineering differential-action controllers are not used because they increase the measurement noise, which can lead to continuous oscillation of the control loop.

P controller

In a P controller there is proportionality between the input variable x_d and the output variable y . However, it only generates a manipulated variable at the output if there is a control difference at the input. This results in a permanent control deviation.

P controller equation $y = K_P * x_d$ $K_P = \text{gain}$

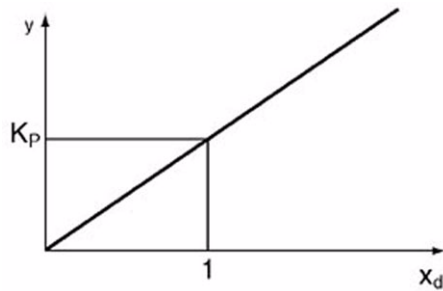
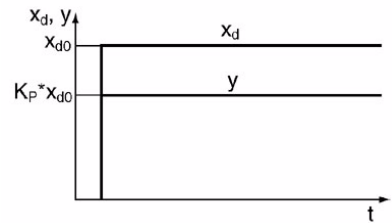
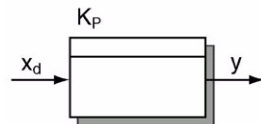


Figure 1.11 P controller characteristic

P controller step response



P controller symbol



I controller

In an I controller the rate of change of the manipulated variable is proportional to the control deviation x_d . No permanent control deviation occurs.

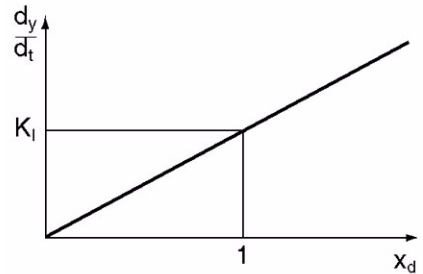
I controller equation

$$y = K_I \int x_d dt$$

$$\leftrightarrow \frac{dy}{dt} = K_I * x_d$$

$\frac{dy}{dt}$ = Rate of change of y

P controller symbol

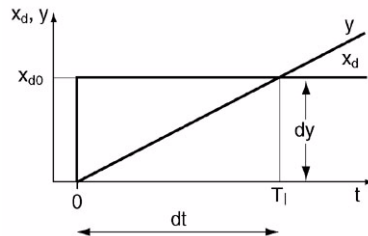


I controller step response

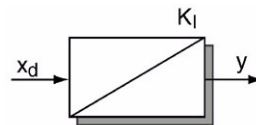
$$\frac{dy}{dt} = K_I * x_{d0} = \frac{x_{d0}}{T_I}$$

$$\leftrightarrow T_I = \frac{1}{K_I}$$

T_I : Integration time
 K_I : Integration coefficient



I controller symbol



PI controller

The PI controller is a combination of a P controller and an I controller, combining the properties of the two. The P component brings about a very fast response, but has the disadvantage that the control difference is not fully eliminated. The I component responds relatively slowly, but causes the control difference to disappear.

PI controller equation

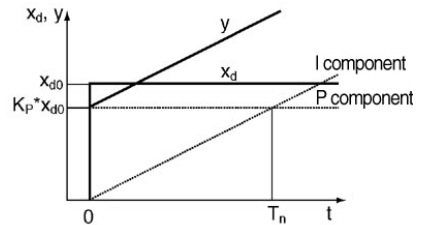
$$y = K_P \cdot x_d + K_I \int x_d dt$$

with $K_I = \frac{K_P}{T_n}$ follows:

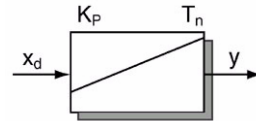
$$y = K_P \cdot x_d + \frac{K_P}{T_n} \int x_d dt$$

K_P : Gain
 T_n : Lag time

PI controller step response



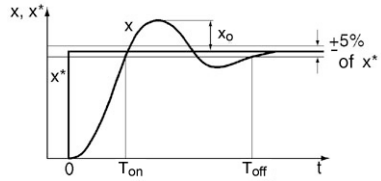
PI controller symbol



Control quality

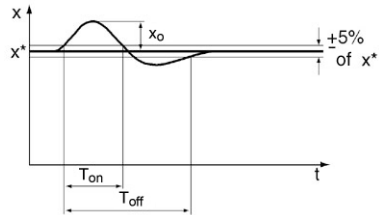
- The following requirements are made of a closed-loop control operation:
 - The control loop must be stable.
 - The control loop must exhibit a certain stationary accuracy.
 - The control loop - i.e. the response to a reference input variable step - must be sufficiently damped.
 - The control loop must be fast enough.
- These requirements are in part mutually contradictory. If the damping is increased, for example, to keep down the overshoot, this necessarily increases the rise time. It is therefore only possible to select the most favourable setting for the control task faced. That is to say, compromises are required.

Control result in response to a reference input variable step change (control response)



- The rise time T_{on} is the time which passes until the reference tolerance band is first reached.
- The correction time T_{off} indicates the time after which the controlled variable definitively enters the tolerance band without leaving it again.
- The overshoot x_o is a measure of the damping of a control loop.

Control result in response to a disturbance step change (disturbance response)

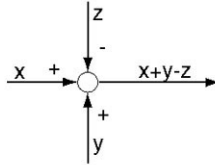


- The control result always results from the interaction of the controlled system and the controller. This demonstrates that the keyword "torque rise time" commonly used in drive engineering does not result solely from the properties of the controller, but is also dependent on the motor parameters. It is therefore not possible to assign a specific torque rise time to a servo inverter.

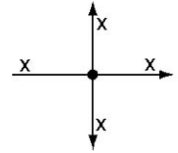
Interlinking of block diagram elements

The elements in a block diagram can be interlinked in one of the following ways:

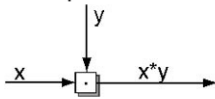
Mixing point:



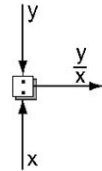
Branch point:



Multiplication point:



Division point:



A.3.5 Basic principle of torque, speed and position control

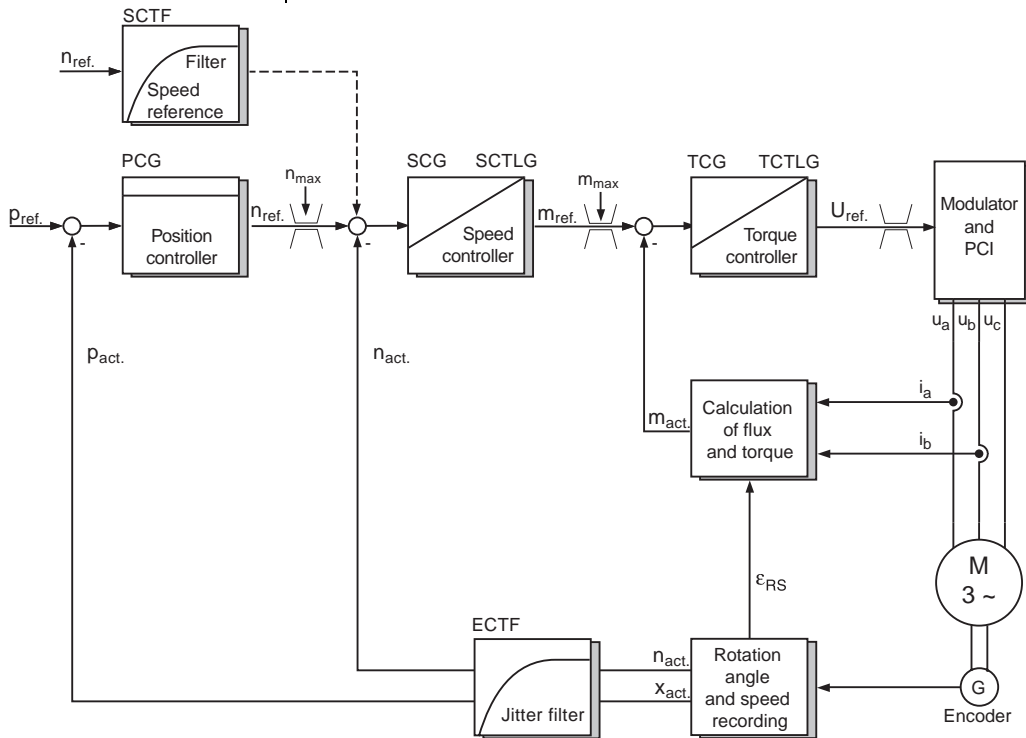


Figure 1.12 Typical control structure in the servocontroller

In positioning drives and servocontrollers the control structure shown in Figure 1.12 is typically used. In this, the position controller/positioning drive is underpinned by a speed and torque controller (current controller) in order to attain a good control response.

The control difference between the reference position ($p_{ref.}$) and the actual position ($p_{act.}$) is the input variable of the position controller. The P position controller delivers a corresponding speed reference ($n_{ref.}$) analogous to the control difference and the P gain (PCG). This is compared against the actual speed value ($n_{act.}$) in the lower-level speed

controller delivered by way of the encoder, the angle of revolution sensor and the jitter filter (ECTF). The control difference is processed in the speed controller proportional (SGG) – integral (SCTLG).

The output signal of the speed controller forms the torque reference ($m_{ref.}$) which is compared against the actual torque ($m_{act.}$) calculated from the machine model. The control difference is also processed in the torque controller proportional (TCG) – integral (TCTLG). The output signal of the torque controller is a voltage reference which is passed to the motor via the pulse-controlled inverter (PCI).

Optimization of speed and torque controllers

The torque controller is set optimally by reading-in the motor data set or by way of the motor identification and the associated automatic parameterization of the control loops. Optimization of the speed controller too, referred to twice the mass moment of inertia (load/motor 1:1) of the motor, is also complete.

The speed controller must, however, also be adapted to the machine or the mechanism coupled to the motor. The following influencing variables are decisive in this:

- The reduced mass moment of inertia of the mechanism and the load referred to the motor shaft
- The elasticity of the mechanism (toothed belt, coupling, torsion of shafts etc.)
- The slack in the gearbox and mechanism

The drive response is checked by means of the step response. This means that a speed step response of approximately 100 rpm is set for the drive, with no limiting due to speed ramps or smoothing.

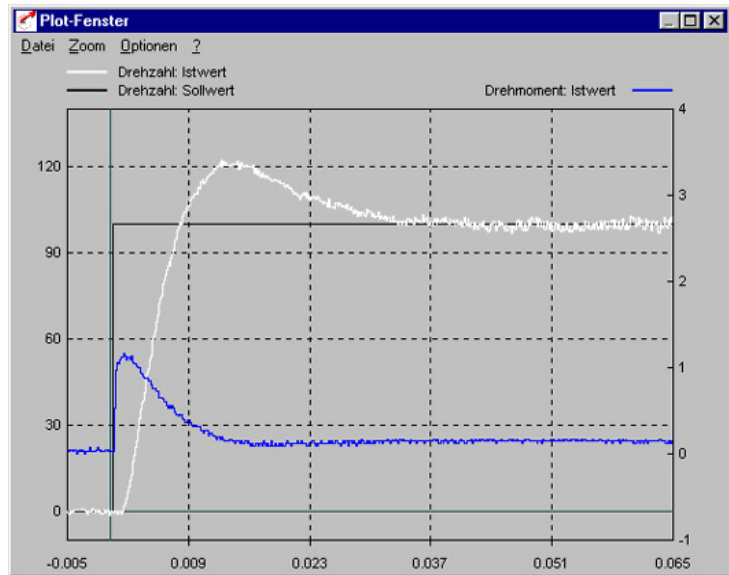


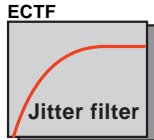
Figure 1.13 Step response of the speed with optimum overshoot of approx. 20 %

Practical tip:

The larger the mass moment of inertia of the mechanism and load of the operating unit, the larger the P gain (SCG) of the speed controller must be. Optimum P gain is attained by a rigid mechanism (no elasticity or slack).

Rule:

- With a rigid drive mechanism (grinding wheel drive - grinding wheel directly on motor shaft) with almost no elasticity and slack the P gain (SCG) is large and the lag time (SCTLG) small.
- With a simple drive mechanism (simple traction drive with long drive belt for power transmission) with high elasticity and slack the P gain (SCG) must be roughly halved relative to a rigid mechanism and the lag time (SCTLG) at least doubled.



Actual speed filter

The actual speed filter should only be adjusted in special applications. The actual speed filter reduces torque fluctuations which can occur due to defective encoder mounting, a poor mechanism or noise on the encoder signal. Reducing the torque fluctuation improves the true-running quality of the drive, though at the same time the drive loses control dynamism.

A small actual speed filter permits higher control dynamism with normal true-running quality.

A large actual speed filter reduces the control dynamism and improves the true-running quality.

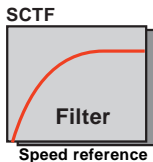
Practical tip:

The actual speed filter preset by loading the motor data set or by the motor identification should only be changed if smoother running is really needed.

Please note that changing the filter time (ECTF) means the P and I components of the speed controller will also need to be re-optimized. As a rough guide: If the filter time (ECTFF) is increased three-fold, the gain (SCG) must be roughly halved and the lag time (SCTLG) at least doubled.

Speed reference filter

By way of the speed reference filter the frequent disturbances on the analog signal in the case of a purely speed control with analog reference input can be filtered out.



Optimization of the position controller

The higher the position controller gain parameter (PCG) is set, the more rigid will be the drive, and the smaller will be the tracking errors during positioning. If the position controller gain is set too high, it will cause overshoot at the destination position or even control instabilities.

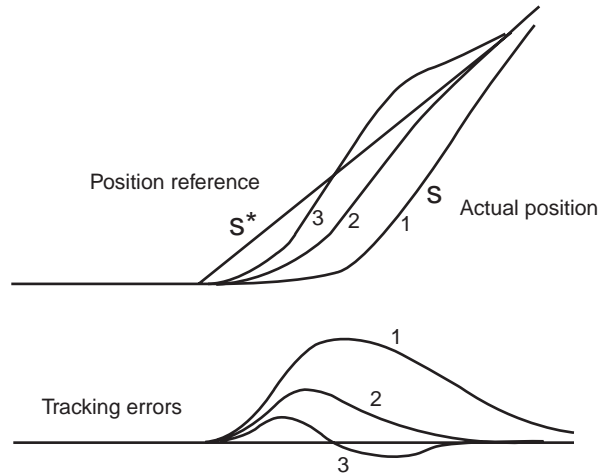


Figure 1.14 Actual position and tracking error in case of:
1 position controller gain too low (large tracking error)
2 position controller gain optimum
3 position controller gain too high (overshoot)

Practical tip:

The higher the dynamics of the speed controller (high gain, short lag time), the more dynamically the position controller can be set. Consequently, for optimization of the position controller the speed controller must first have been optimized.

A.3.6 DC network operation



DC network operation of the c-line drive controllers is permissible only with written approval from LUST - see section 3.2.21.

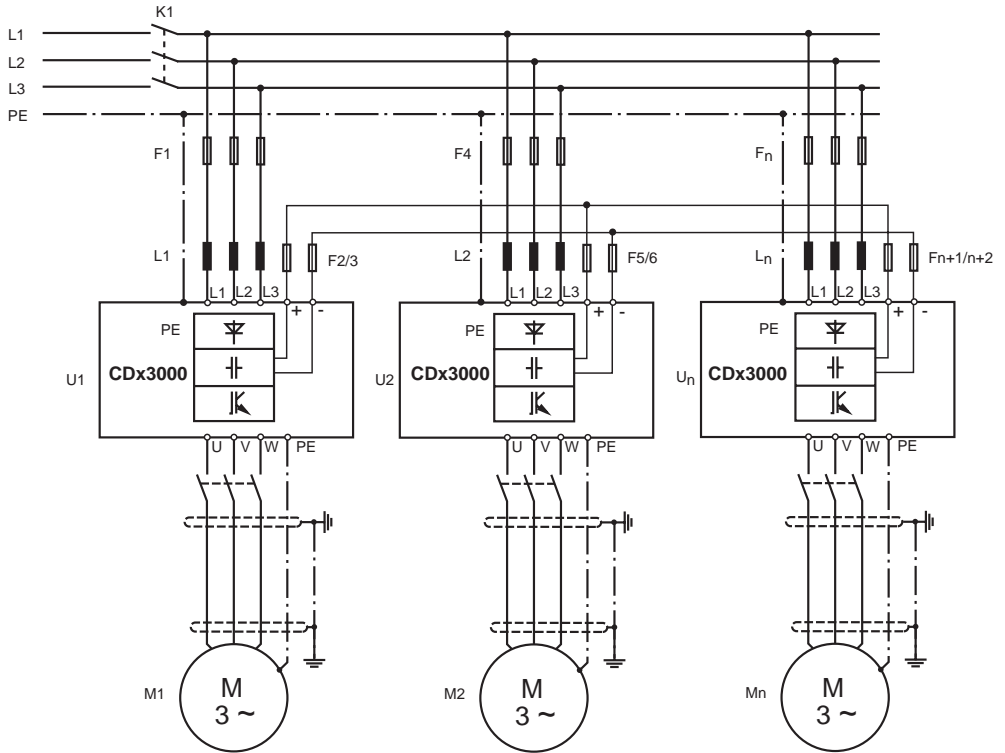


Bild 1.15

Circuitry example - DC network operation with c-line drive controllers

Project planning notes for DC network operation of three-phase c-line drive controllers


Subject	Project planning notes
Mains connection	<ul style="list-style-type: none"> All drive controllers must be operated with a line choke. The line choke limits the mains current and provides current/power symmetry of the drive controller input circuits.
Mains fuse (F1) with signal contact	<ul style="list-style-type: none"> By the use of mains fuses with signal contact the "Mains power supply failure" fault can be responded to by shutting down the entire DC network. As a result the remaining drive controllers in the DC network are not overloaded.
Mains power connection condition	<ul style="list-style-type: none"> It must be ensured that all drive controllers are connected simultaneously (K1) to the mains power.
DC-link connection	<ul style="list-style-type: none"> Make short cable connections to the common DC-link centre point. Use cable cross-section corresponding to mains power cable cross section (see Operation Manual and section 3.2.2). Select DC-link fuses corresponding to the cable cross-section and local regulations. The fuses protect the cable. <p>Tip: Where the DC network comprises only two drive controllers only one fuse pair (F3/4) is sufficient for protection purposes.</p> <div style="border: 1px solid black; padding: 5px; margin-top: 10px;">  <p>If the DC network is connected to the mains while a drive controller has an internal short-circuit on the DC link, the defective drive controller is automatically isolated from the DC network by its PTC precharging circuit. All other drive controllers can continue in operation; see Figure 1.16.</p> </div>

Tabelle 1.28 Project planning notes for DC network operation of three-phase c-line drive controllers

Subject	Project planning notes
Design of the external braking resistors	<p>If the energy balance in DC network operation is regenerative in individual operating situations, the drive controllers must be operated with external braking resistors to absorb the regenerative energy. The following conditions must be met when designing the braking resistors:</p> <ol style="list-style-type: none"> 1. The ohmic value of the external braking resistor must not be less than the minimum ohmic connected load permitted by the drive controller. 2. Adding together the peak braking powers of all braking resistors operated in the DC network produces the peak braking power referred to the DC network. $P_{SDC} = P_{SW1} + P_{SW2} + \dots P_{SWn}$ <p>P_{SDC} = total peak braking power in the DC network P_{SW1} = peak braking power of braking resistor 1</p> 3. The continuous braking power of the individual braking resistor is ascertained by calculation of the effective braking power. $P_{eff} = \sqrt{\frac{P_{SW1}^2 \cdot t_1 + P_{SW2}^2 \cdot t_2 + \dots P_{SWn}^2 \cdot t_n}{T}}$ <p>P_{SW} = peak braking power of the selected braking resistor $t_1, 2x_n$ = braking time 1.2 m ... n</p> <hr/> <p>The permissible continuous braking power of the selected braking resistor must be $> P_{eff}$. The sampling time (T) must be < 150 s.</p> <hr/>

Tabelle 1.28 Project planning notes for DC network operation of three-phase c-line drive controllers

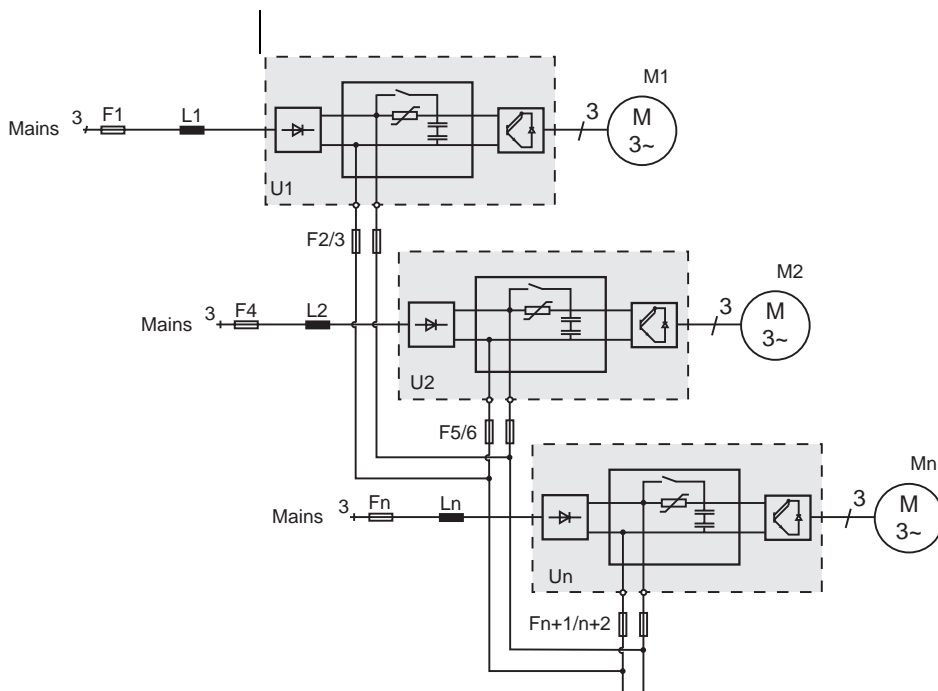


Figure 1.16 DC network operation with PTC precharging circuit



- DC network operation with VF1000S/M/L, MC6000, MC7000 and CDE/CDB3000 above 22 kW is not permitted.
- DC network operation is permissible only with written approval from Lust.



DC network operation with multiple 1-phase drive controllers fed via L1/N, L2/N and/or L3/N is not permitted. The feed mode creates a B6 bridge connection which results in destruction of the drive controllers.

A.4 Motors

A.4.1 Thermal classes of electric motors

The various materials used to insulate electric motors are classified in Annex A of the superseded standard DIN VDE 0530 part I dated July 1991 and according to DIN IEC 60085 / VDE 0301 part I into *thermal classes* (formerly: *insulating material classes*) (see Table A.29).

Thermal class (insulating material class)	Limit temperature of insulating material °C	Temperature rise limit of winding K
B, F, H	130, 155, 180	80, 105, 125

Table A.29 Thermal classes of insulating materials

The assigned maximum permissible *temperature rises* are selected such that under continuous load, including adequate safeguards, a long service life is guaranteed. Thus the thermal class B common for motors permits a continuous temperature of 130 °C: Based on a maximum permissible *ambient temperature* of 40 °C, the winding, measured by the resistance method, must attain a temperature rise limit of 80 K; 10 K is allowed as a safety clearance because of possible locally uneven temperature distribution (see Figure 1.17).

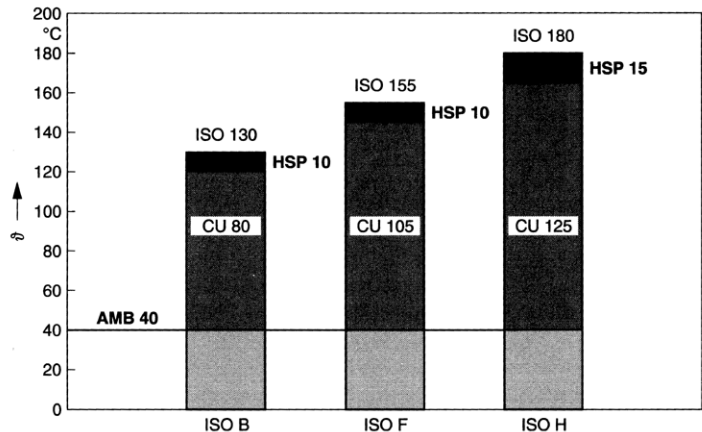


Figure 1.17 Limit temperature of the insulating material (ISO) and temperature rise limit (above 40 °C ambient temperature AMB) of AC windings (CU) in motors up to 200 kW, determined by the resistance method to DIN EN 60034-1 / VDE 0530 part I and DIN IEC 60085 / VDE 301 part I with a supplement for »hot spots« (HSP)

Figure 1.18 shows that the theoretical service life of an insulating material falls to around 50 % if the temperature is increased by 10 K.

By choosing a higher thermal class (e.g. F or H) two goals can optionally be attained:

- Higher load withstand capability with the same theoretical service life.
- Longer service life and higher safety with equal loading.

Mostly the enhanced insulation is deployed to achieve greater operational safety under abnormal operating conditions.

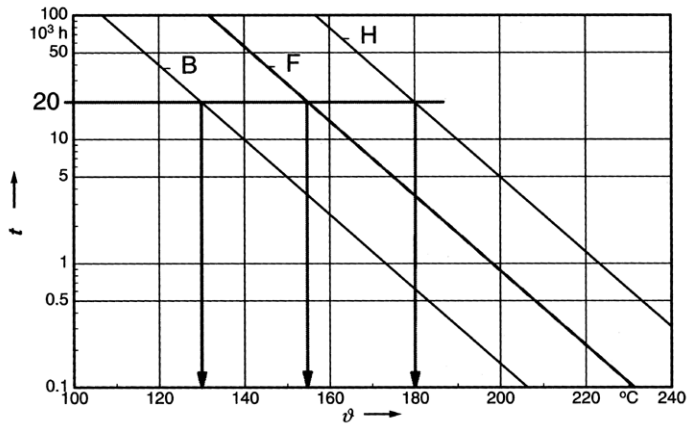


Figure 1.18 Theoretical service life t of insulating material components of thermal classes B, F and H at various temperatures ϑ

A.4.2 Colour coding of a threshold value PTC to DIN 44081

NAT C	Colour code	NAT f**	Colour code	NAT C	Colour code
60	White/grey	110	Brown/brown	150	Black/black
70	White/brown	120	Grey/grey	155	Blue/black
80	White/white	130	Blue/blue	160	Blue/red
90	Green/ green	140	White/blue	170	White/green
100	Red/red	155	White/black	180	White/red

Table A.30 Classification and colour coding of the nominal response temperature to DIN44081

Typical resistance range of a DIN PTC

Temperature (°C)	Typical resistance values (Ω)
-20 ... 150	50 ... 4000

Table A.31 Typical resistance values of a DIN-PTC with a TNF of 90 ... 160 °C

Diagram of a DIN PTC

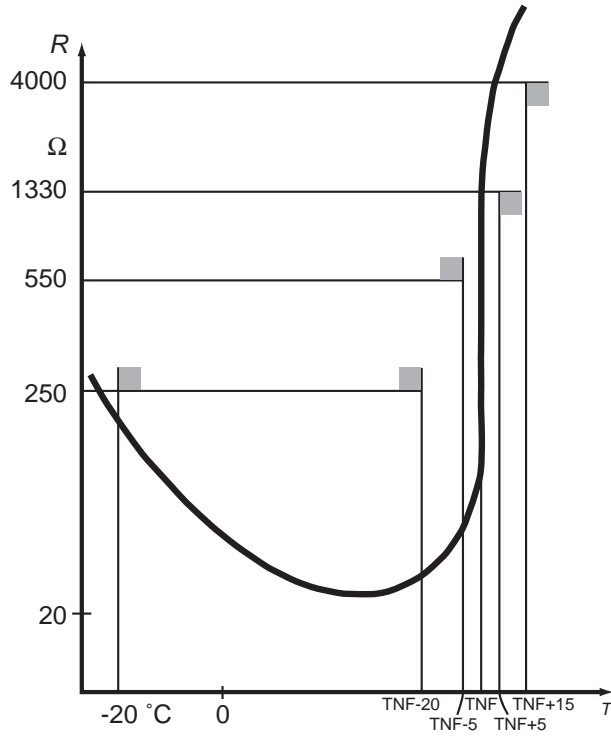


Figure 1.19 Resistance diagram as function of temperature of a DIN PTC



The resistance of the DIN PTC is always defined relative to its nominal response temperature (TNF, formerly termed T_{NAT}).

The measurable resistance is dependent on the fitting variant (PTC in-line configuration).

PTC evaluation dependent on the temperature curve of an IEC standard motor

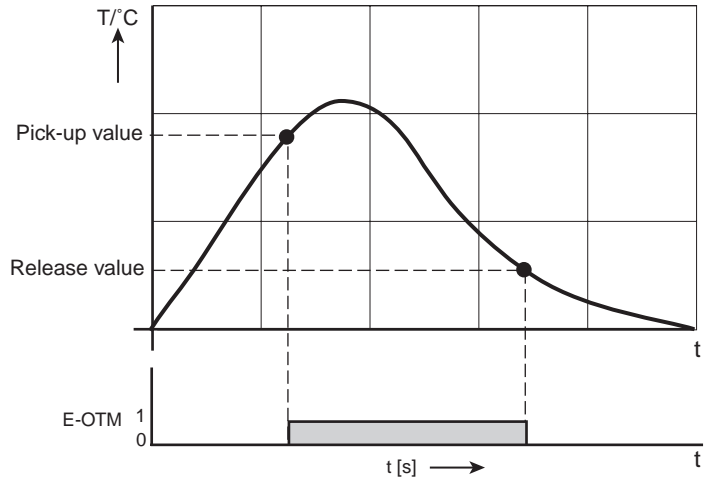
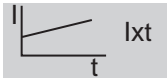


Figure 1.20 PTC evaluation operation diagram



Ixt monitoring

Ixt monitoring protects the motor against overheating over its entire speed range. This is especially important for internally cooled motors, since in lengthy service at low speed the cooling provided by the fan and the housing is insufficient. When set correctly, this function replaces a motor circuit-breaker. The characteristic can be adapted to the operating conditions by way of interpolation points.

A.4.3 Linear PTC KTY-130-gel

Typical resistance values of a linear PTC (KTY 84 - 130)

Temperature (°C)	Typical resistance values (Ω) Tolerance ~ +/- 6%
-20	424
0	498
20	581
50	722
80	852
100	1000
150	1334

Table A.32 Typical resistance values of a linear PTC of type KTY 84-130

Diagram of PTC KTY 84-130

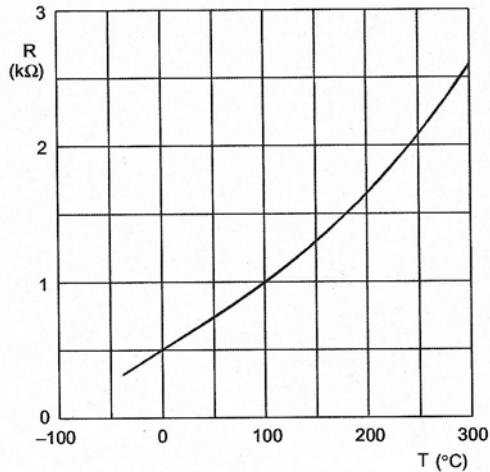


Figure 1.21 Resistance diagram as function of temperature of a PTC KTY 84-130

A.4.4 Motor protection possibilities

Motor protection possibilities

	A	B	C	D	C+D
Overload type	Motor circuit-breaker. e.g. PKZM ¹⁾	Thermistor protective relay	Motor PTC monitoring of the drive controller	Software function: motor protection of the drive controller	Motor PTC monitoring and motor protection of the drive controller
Overload in continuous operation ²⁾	●	●	●	●	●
Heavy starting ³⁾	●	◐ ⁴⁾	◐ ⁴⁾	●	●
Blocking ²⁾	●	●	●	●	●
Blocking ³⁾	●	◐ ⁴⁾	◐ ⁴⁾	●	●
Ambient temperature >50 °C ²⁾	○	●	●	○	●
Impairment of cooling ²⁾	○	●	●	○	●
Drive controller operation <50 Hz	○	●	●	◐ ⁵⁾	●
<p>○ No protection ◐ Limited protection ● Full protection</p> <p>1) Operation in the motor cable between drive controller and motor permitted. 2) The drive controller and motor have the same power rating (1:1). 2) The drive controller is at least four times larger than the motor (4:1). 4) Effective when motor warm, too long response time when motor cold. 5) No full protection, because only the permissible current is applied as the basis.</p>					

Table A.33 Motor protection possibilities

A.4.5 Typical data of standard three-phase AC motors

Standard 3-phase AC motor 3000 rpm, 50 Hz

Three-phase AC motors with squirrel-cage rotor to DIN VDE 0530, 3000 rpm, 50 Hz, IP54 protection, internally cooled

Size	Power P in kW	Efficiency η in %	Rated torque M_n in Nm	Mass moment of inertia J in kgm ²	Rated current at 230/400 V
56S/2	0.09	50	0.31	0.000130	0.80/0.5
56L/2	0.12	49	0.41	0.000160	0.96/0.6
63S/2	0.18	57	0.63	0.000141	1.22/0.75
63L/2	0.25	59	0.86	0.000188	1.5/0.91
71S/2	0.37	69	1.25	0.00035	1.83/1.1
71L/2	0.55	75	1.87	0.000455	2.45/1.45
80S/2	0.75	72	2.58	0.000678	3.25/1.93
80L/2	1.1	78	3.73	0.000904	4.6/2.7
90S/2	1.5	78	5.1	0.00137	5.8/3.4
90L/2	2.2	82	7.4	0.00183	8.4/4.9
100S/2	3.0	73	10.0	0.00282	12.5/7.3
112M/2	4.0	80	13.3	0.00556	14.8/8.6
132S/2	5.5	85	18.3	0.00837	21.1/12.1
132S/2a	7.5	84	24.9	0.012	27.1/15.7
160M/2	11.0	87	36.0	0.033	37.3/21.6
160M/2a	15.0	88	49.0	0.045	48.1/28.1
160L/2	18.5	92	60.0	0.054	59.1/34.1
180M/2	22.0	91	71.0	0.073	74.1/43.1
200L/2	30.0	90	97.0	0.12	96.1/56.1
200L/2a	37.0	92	119.0	0.15	114.1/66.1
225M/2	45.0	93	145.0	0.22	148.1/81.1
250M/2	55.0	95	177.0	0.36	170.1/98.1
280S/2	75.0	93	241.0	0.61	-/135.1
280M/2	90.0	92	289.0	0.70	-/165.1
315S/2	110.0	93	353.0	1.46	-/202.1
315M/2	132.0	92	424.0	1.70	-/244.1
315M/2a	160.0	93	514.0	2.00	-/289.1
315M/2b	200.0	87	641.0	2.20	-/385.1

The data given represent mean values which may vary slightly depending on manufacturer.

Table A.34 Standard 3-phase AC motor 3000 rpm, 50 Hz

Standard 3-phase AC motor 1500 rpm, 50 Hz

Three-phase AC motors with squirrel-cage rotor to DIN VDE 0530, 1500 rpm, 50 Hz, IP54 protection, internally cooled

Size	Power P in kW	Efficiency η in %	Rated torque M_n in Nm	Mass moment of inertia J in kgm ²	Rated current at 230/400 V
56S/4	0.06	42	0.42	0.000130	0.62/0.4
56L/4	0.09	39	0.63	0.000160	0.97/0.6
63S/4	0.12	49	0.85	0.000210	0.97/0.6
63L/4	0.18	63	1.26	0.000280	1.1/0.7
71S/4	0.25	61	1.72	0.000560	1.5/0.9
71L/4	0.37	65	2.56	0.000730	2.0/1.2
80S/4	0.55	73	3.8	0.00128	2.7/1.6
80L/4	0.75	80	5.1	0.00165	3.4/2.0
90S/4	1.1	72	7.5	0.00235	5.1/3.0
90L/4	1.5	77	10.2	0.00313	6.5/3.8
90L/4a	2.2	76	15.0	0.00316	9.6/5.6
100L/4	2.2	76	14.9	0.00450	9.5/5.5
100L/4a	3.0	77	20.3	0.00600	12.9/7.5
112M/4	4.0	83	27.0	0.0199	15.7/9.1
132S/4	5.5	85	36.0	0.0233	20.0/11.6
132M/4	7.5	87	49.0	0.0317	28.1/16.3
132M/4a	9.2	87	60.0	0.0354	35.1/20.1
160M/4	11.0	89	72.0	0.062	39.4/23.1
160L/4	15.0	89	98.0	0.083	54.1/31.1
180M/4	18.5	91	121.0	0.127	66.1/38.1
180L/4	22.0	94	143.0	0.153	80.1/44.1
200L/4	30.0	89	195.0	0.249	99.1/57.1
225S/4	37.0	91	240.0	0.392	124.1/70.1
225M/4	45.0	95	290.0	0.474	152.1/85.1
250M/4	55.0	93	355.0	0.736	176.1/98.1
280S/4	75.0	94	484.0	1.22	-/140.1
280M/4	90.0	95	581.0	1.46	-/168.1
315S/4	110.0	94	707.0	2.12	-/210.1
315M/4	132.0	96	849.0	2.54	-/240.1
315M/4a	160.0	96	1029.0	2.97	-/285.1
315M/4b	200.0	93	1286.0	3.25	-/370.1

The data given represent mean values which may vary slightly depending on manufacturer.

Table A.35 Standard 3-phase AC motor 1500 rpm, 50 Hz

Standard 3-phase AC motor 1000 rpm, 50 Hz

Three-phase AC motors with squirrel-cage rotor to DIN VDE 0530, 1000 rpm, 50 Hz, IP54 protection, internally cooled

Size	Power P in kW	Efficiency η in %	Rated torque M_n in Nm	Mass moment of inertia J in kgm ²	Rated current at 230/400 V
63S/6	0.09	47	0.97	0.00031	0.88/0.55
63L/6	0.12	41	1.29	0.00042	1.2/0.74
71S/6	0.18	58	1.89	0.00091	1.23/0.75
71M/6	0.25	64	2.58	0.0012	1.66/1.0
80S/6	0.37	57	3.84	0.0022	2.5/1.5
80L/6	0.55	69	5.71	0.0028	3.0/1.78
90S/6	0.75	69	7.83	0.0037	4.1/2.3
90L/6	1.1	68	11.5	0.0050	5.6/3.4
100L/6	1.5	73	15.1	0.010	7.2/4.2
112M/6	2.2	81	22.1	0.018	9.85/5.75
132S/6	3.0	82	29.8	0.031	13.5/7.9
132M/6	4.0	84	39.8	0.038	16.8/9.8
132M/6a	5.5	81	55.8	0.045	23.3/13.5
160M/6	7.5	85	74.0	0.093	28.6/16.6
160L/6	11.0	86	109.0	0.127	42.1/24.1
180M/6	13.0	85	130.0	0.168	49.1/28.1
180L/6	15.0	85	148.0	0.192	55.1/32.1
200LK/6	20.0	88	196.0	0.281	73.1/42.1
200L/6	22.0	91	215.0	0.324	78.1/45.1
225M/6	30.0	89	290.0	0.736	103.1/60.1
250M/6	37.0	93	360.0	1.01	123.1/71.1
280S/6	45.0	92	436.0	1.48	156.1/90.1
280M/6	55.0	92	533.0	1.78	190.1/110.1
315S/6	75.0	92	727.0	2.63	-/143.1
315M/6	90.0	93	878.0	3.08	-/170.1
315M/6a	110.0	95	1061.0	3.63	-/205.1
315M/6b	132.0	93	1273.0	4.17	-/250.1
355S/6	160.0	95	1543.0	10.7	-/290.1
355S/6a	200.0	95	19.29.0	12.7	-/365.1

The data given represent mean values which may vary slightly depending on manufacturer.

Table A.36 Standard 3-phase AC motor 1000 rpm, 50 Hz

A.4.6 Typical data of asynchronous servomotors

Asynchronous servomotors with squirrel-cage rotors to DIN 42 950, self-cooling, IP 65 protection

Size	Power P in kW	Efficiency η in %	Rated torque M_n in Nm	Mass moment of inertia J in kgm ²	Nominal speed n in rpm	Rated current in A
ASM(H)31	2.1	83.0	13.0	0.0070	1500	5.2
ASM(H)32	2.7	85.0	17.0	0.0090	1500	6.8
ASM(H)33	3.6	85.0	23.0	0.0130	1500	8.7
ASM(H)34	5.5	87.0	35.0	0.0209	1500	12.6
ASM(H)24	2.1	84.0	10.0	0.00298	2000	5.3
ASM(H)25	2.7	85.0	13.0	0.00384	2000	6.6
ASM(H)11	0.41	76.0	1.3	0.00028	3000	1.4
ASM(H)12	0.54	77.0	1.7	0.00037	3000	1.8
ASM(H)13	0.72	79.0	2.3	0.00047	3000	2.3
ASM(H)14	1.1	80.0	3.5	0.00065	3000	3.3
ASM(H)15	1.5	82.0	4.7	0.00089	3000	4.5
ASM(H)21	1.1	82.0	3.5	0.00109	3000	3.0
ASM(H)22	1.5	83.0	4.7	0.00144	3000	3.9
ASM(H)2 3	2.2	84.0	7.0	0.00215	3000	5.6

The data given represent mean values which may vary slightly depending on manufacturer.

Table A.37 Asynchronous servomotors, self-cooling

Asynchronous servomotors with squirrel-cage rotors to DIN 42 950, forced cooling, IP 65 protection

Size	Power P in kW	Efficiency η in %	Rated torque M_n in Nm	Mass moment of inertia J in kgm ²	Nominal speed n in rpm	Rated current in A
ASF(V)31	2.8	80.0	18.0	0.0070	1500	7.0
ASF(V)32	3.6	83.0	23.0	0.0090	1500	8.9
ASF(V)33	5.0	85.0	32.0	0.0130	1500	11.6
ASF(V)34	7.4	87.0	47.0	0.0209	1500	15.4
ASF(V)24	2.7	83.0	13.0	0.00298	2000	6.7
ASF(V)25	3.4	85.0	16.5	0.00384	2000	8.2

The data given represent mean values which may vary slightly depending on manufacturer.

Table A.38 Asynchronous servomotors, forced cooling

Size	Power P in kW	Efficiency η in %	Rated torque M_n in Nm	Mass moment of inertia J in kgm ²	Nominal speed n in rpm	Rated current in A
ASF(V)11	0.54	76.0	1.7	0.00028	3000	1.8
ASF(V)12	0.72	78.0	2.3	0.00037	3000	2.4
ASF(V)13	0.94	79.0	3.0	0.00047	3000	2.9
ASF(V)14	1.5	81.0	4.7	0.00065	3000	4.3
ASF(V)15	2.0	82.0	6.5	0.00089	3000	6.2
ASF(V)21	1.5	82.0	4.7	0.00109	3000	3.9
ASF(V)22	2.0	83.0	6.5	0.00144	3000	5.0
ASF(V)23	3.1	85.0	10.0	0.00215	3000	7.4

The data given represent mean values which may vary slightly depending on manufacturer.

Table A.38 *Asynchronous servomotors, forced cooling*

A.4.7 Overview of data of synchronous servomotors (LSH)

Overview of technical data

Tech. data	Standstill torque	Rated torque	Rated current at 560 V	Rated current at 320 V	Nominal speed	Mass moment of inertia
Motor	M_0 [Nm]	M_N [Nm]	I_N [A]	I_N [A]	n_N [rpm]	kg/cm ²
LSH-050-1 ¹⁾	0.25	0.23	-	0.66	4500	0.06
LSH-050-2 ¹⁾	0.5	0.45	-	1.11	4500	0.08
LSH-050-3 ¹⁾	0.7	0.65	-	1.49	4500	0.10
LSH-074-1 ²⁾	0.8	0.7	0.95	1.65	3000	0.5
LSH-074-2 ²⁾	1.6	1.3	1.51	2.65	3000	0.7
LSH-074-3 ²⁾	2.7	2.2	2.1	3.65	3000	1.1
LSH-097-1 ²⁾	3.7	3.0	2.6	4.55	3000	1.7
LSH-097-2 ²⁾	5.7	4.3	3.5	6.1	3000	2.6
LSH-097-3 ²⁾	7.8	5.5	4.3	7.5	3000	3.5
LSH-127-1 ³⁾	10.5	7.8	7.3	-	3000	6.8
LSH-127-2 ³⁾	13.5	10.1	9.0	-	3000	8.3
LSH-127-3 ³⁾	17.0	13.5	11.6	-	3000	11.0
LSH-127-4 ³⁾	25	20.0	14.2	-	3000	15.3

1) DC link voltage 320 V

2) DC link voltage 320 V/560 V

3) DC link voltage 560 V

Table A.39 Technical data



For detailed electrical data and dimensional drawings refer to the "LSH Servomotors" order catalogue.

A.4.8 Typical data of EUSAS system motors

Size	Type	P _N	n _N	I _N at 230 V	I _N at 400 V	η 4/4	cos φ	M _N	M _K /M _N	J _{mot} x10 ⁻³	P _N	n _N	I _N
IEC		[kW]	[rpm]	[A]	[A]	[%]		[Nm]		[kgm ²]	[kW]	[rpm]	[A]
63 ¹⁾	64K4	0.12	1350	0.9	0.5	55.0	0.61	0.9	2.2	0.30	0.21	2338	0.9
	64N4	0.18	1350	1.0	0.6	60.0	0.66	1.3	2.2	0.40	0.31	2338	1.0
71 ¹⁾	72 K4	0.25	1350	1.3	0.8	60.0	0.73	1.8	2.3	0.60	0.43	2338	1.3
	72N4	0.37	1370	1.9	1.1	65.0	0.76	2.6	2.4	0.80	0.64	2373	1.9
80 ¹⁾	81 K4	0.55	1390	2.5	1.5	67.0	0.75	3.8	2.4	1.50	0.95	2408	2.5
	81N4	0.75	1390	3.5	2.0	72.0	0.76	5.2	2.4	1.80	1.30	2408	3.5
90 ¹⁾	91 S4	1.1	1390	4.6	2.7	75.0	0.77	7.6	2.4	2.80	1.91	2408	4.6
	91 L4	1.5	1400	6.2	3.6	78.0	0.79	10.2	2.7	3.50	2.60	2425	6.2
100 ²⁾	101L4	2.2	1420		5.0	80.5	0.80	14.8	2.4	6.00	4.40	2840	10
	101LA4	3	1410		6.6	82.0	0.82	20.0	3.0	7.00	6.00	2820	13.2
112 ²⁾	114M4	4	1430		8.5	83.5	0.81	26.7	3.0	11.0	8.0	2860	17
	114ML4	5.5	1435		12.7	82.0	0.77	36.6	3.4	14.0	11.0	2870	25.4
132 ²⁾	134S4	5.5	1450		11.5	86.0	0.81	36.2	3.1	21.0	11.0	2900	23
	134M4	7.5	1450		15.1	87.0	0.82	49.4	3.0	30.0	15.0	2900	30.2
	134ML4	9.2	1450		20.0	85.0	0.80	60.6	3.0	45.0	18.4	2900	40
	134ML4	10	1440		21.0	85.0	0.81	66.3	2.7	45.0	20.0	2880	42
160 ²⁾	161M4	11	1445		22.0	88.5	0.84	73	2.7	75	22	2890	44
	161L4	15	1455		29.0	90.0	0.83	99	3.2	92	30	2910	58
180 ²⁾	181M4	18.5	1460		35	90.5	0.83	121	3.0	139	37	2920	70
	181L4	22	1420		41	91.0	0.84	148	3.0	158	44	2840	82
200 ²⁾	201L4	30	1465		55	91.5	0.86	196.	2.8	262	60	2930	110
225 ²⁾	226S4	37	1470		68	92.0	0.85	240	2.8	406	74	2940	136
	226M4	45	1475		81	92.5	0.87	291	2.9	469	90	2950	162
250 ²⁾	251M4	55	1470		98	93.0	0.86	357	3.1	660	110	2940	196
	251ML4	75	1480		134	94.0	0.80	484	2.2	880	150	2960	268
280 ²⁾	281S4	75	1485		135	93.5	0.86	482	3.0	1120	150	2970	270
	281M4	90	1480		157	94.0	0.88	581	2.9	1460	180	2960	314
	281ML4	110	1480		190	94.0	0.89	710	3.1	2680	220	2960	380

1) 87 Hz/400 V (EUSAS version)
2) 100 Hz/400 V (EUSAS version)

Table A.40 4-pole system motor base files

EUSAS version

EUSAS motors with one speed are executed with a varying-voltage winding and can be used at constant rated power for voltages and frequencies in the following ranges:

- a) Motors up to and including size 90: Varying-voltage winding





Delta / Star

220 - 230 - 240 V / 380 - 400 - 420 V at 50 Hz

220 - 255 - 280 V / 380 - 440 - 480 V at 60 Hz

- b) Motors from size 100: Varying-voltage winding and voltage-switchable

There are 4 configuration options; the motors are executed with 9 stator terminals.

Rated power P_N	
Delta (basic configuration)	
	380 - 400 - 420 V at 50 Hz 380 - 440 - 480 V at 60 Hz
Double delta	
	190 - 200 - 210 V at 50 Hz 190 - 220 - 240 V at 60 Hz
Star	
	660 - 690 - (730) V at 50 Hz 660 - 760 - (830) V at 60 Hz
Double star	
	330 - 346 - 365 V at 50 Hz 330 - 380 - 415 V at 60 Hz

The motors are rated in the rating data according to ISO class B but manufactured to ISO class F, and so have higher load capacity in operation at the rated data:

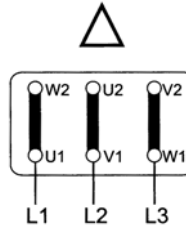
- a) At rated power and voltage the coolant temperature can be increased from 40 °C to 60 °C.
- b) If 40 °C is not exceeded, in uniform operation the rated power can be increased by around 10 %.

The technical data apply to the ratings, i.e. rated voltage and rated frequency. If the motors are operated above or below the rated voltage in the variable range, the stator winding to class F is utilized.

The rating of the varying-voltage winding includes voltage fluctuations from the specified varying voltages in the system of $\pm 5\%$ at constant power output. Figures in bold are rated values.

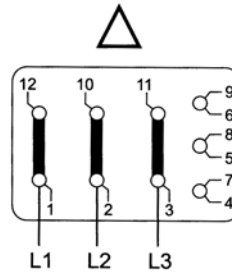
Terminal connection for EUSAS motors up to and including size 90:

220 - 240 V, 50 Hz
 220 - 280 V, 60 Hz
 Delta configuration

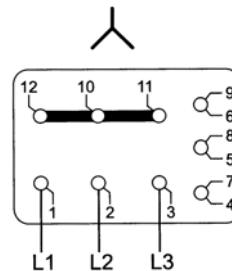


Terminal connection for EUSAS motors from size 100 to 280:

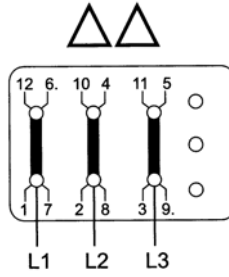
380 - 420 V, 50 Hz
 380 - 480 V, 60 Hz
 Delta configuration
 Standard delivery



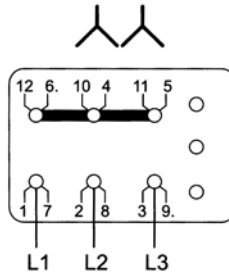
660 (- 730 V), 50 Hz
 660 (- 280 V), 60 Hz
 Star configuration



190 - 210 V, 50 Hz
 190 - 240 V, 60 Hz
 Delta/Delta configura-
 tion



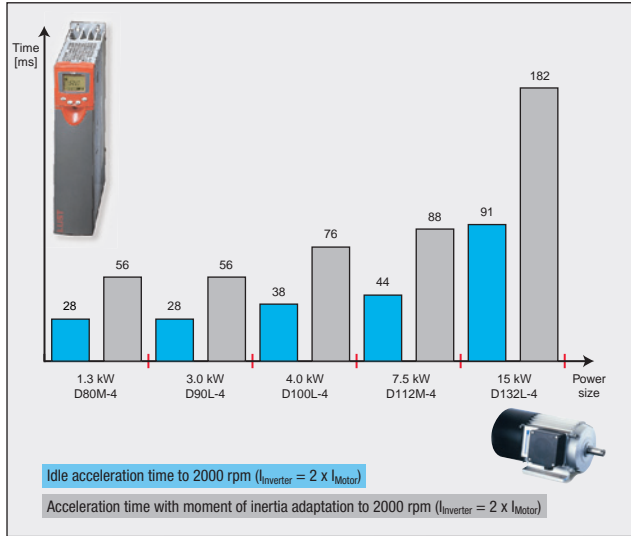
330 - 365 V, 50 Hz
 330 - 415 V, 60 Hz
 Star/Star configuration



A.4.9 Typical data of slim-line three-phase AC motors made of extruded aluminium section

Properties of the three-phase AC motors

The long, slim three-phase AC motors made of extruded aluminium section are optimally attuned to the CDA3000 and CDB2000/3000 inverters. They usually construct a size smaller than standard IEC motors (with the same output in mode S1) and are as dynamic as asynchronous servomotors.



Technical data of motors

Asynchronous three-phase AC motors for Δ 360 V / \triangle 208 V


	Design	Length	Output shaft	Moment of inertia Without encoder	Rated power	Nominal torque	Rated current Δ 360 V / \triangle 208 V	Nominal speed	Efficiency	cos ϕ
Order reference Motor type		[mm]	[mm]	[kgcm ²]	[kW]	[Nm]	[A]	[rpm]		
182022100 4DF71L-4	B14	207	14 x 30	13.1	0.75	3.67	1.95/3.4	1950	0.77	0.8
182022200 4D80e-4	B3	233	19 x 40	14.6	1.1	5.33	2.9/5.0	1970	0.8	0.76
182022300 4D90Ld-4	B3	304.5	24 x 50	39.2	3	14.5	6.8/11.8	1970	0.83	0.86
182022400 4D100Lc-4	B3	309	28 x 60	71.6	4	19.3	8.9/15.4	1980	0.84	0.86
182022500 4D112M-4	B3	329	28 x 60	147	7.5	35.4	16.4/28.4	2020	0.85	0.86
182022600 4D132L-4	B3	484	38 x 80	599	15	70.2	33/57	2040	0.88	0.83

Table A.41 Technical data

A.4.10 New connection markings for rotating electrical machines

Introduction

The connection markings of rotating electrical machines will in future be unified in accordance with the revised norm EN 60034-8:2002. It stipulates that all national standards contradicting EN 60034-8:2002 must be withdrawn by 1st October 2005. In Germany this affects the old DIN 60034-8:1972 + A1:1990 + A2:1996 (VDE 0530 part 8).

The motor manufacturers organized in the ZVEI (German Electrical and Electronic Manufacturers' Association) intend to switch to the new norm with effect from 1st January 2005.

General points on EN 60034-8

The norm applies to AC and DC machines and specifies:

- Rules for identification of winding connection points
- Marking of winding connections
- Direction of rotation
- Relationship between connection markings and direction of rotation
- Connection marking and accessories
- Connection diagrams for machines for general applications

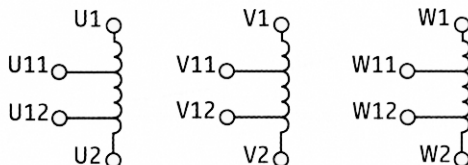
Some key changes

The examples set out in the following are intended to give an impression of the changes to the standard. They cannot reflect all the changes in detail. It is therefore recommended that readers purchase the standard (source: Beuth-Verlag, Berlin).

1. Changes to terminal labels

The connection diagram for a three-phase winding with two taps presents an example of how the terminal labels and symbols are changing.

New: EN 60034-8



Alt: DIN VDE 0530 part 8

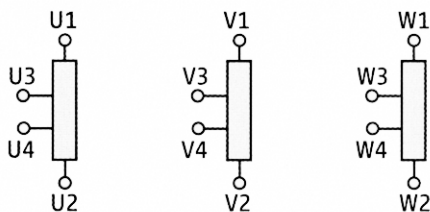


Figure 1.22 Three-phase winding, two taps per element according to the new EN 60034-8 and the old DIN VDE 0530 part 8 respectively

2. Rules for marking of auxiliary terminals

Auxiliary terminals are now to be marked using the ancillary equipment label in conjunction with:

- a prefix, identifying the relevant circuit or the unit;
- a suffix, identifying the function of the conductor.

BA	AC brake
BD	DC brake
BW	Brush wear detector
CA	Capacitor
CT	Current transformer
HE	Heater
LA	Lightning arrester
PT	Potential transformer
R	Resistance thermometer

Table A.42 Ancillary equipment

SC	Surge capacitor
SP	Surge protector
S	Switches incl. plugging switches
TB	Thermostat opening on increase of temperature
TC	Thermocouple
TM	Thermostat closing on increase of temperature
TN	Thermistor with negative temperature coefficient
TP	Thermistor with positive temperature coefficient
K	Recommendation: Temperature sensor based on silicon diode

Table A.42 Ancillary equipment

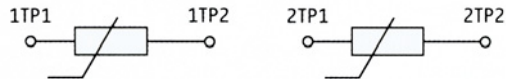


Figure 1.23 Example of a two-conductor arrangement of a temperature sensor with a positive temperature coefficient

- Note: If there is only one circuit the digit can be omitted.
- Recommendation: The polarity should be identified by + and -.

3. Detailing of direction of rotation

The direction of rotation is the direction as viewed when looking at the drive side. If the machines are connected in accordance with the standardized connection labels, the direction of rotation is clockwise. In all other cases, including single-direction machines, the direction must be indicated by a clearly visible arrow.

4. Inclusion of connection diagrams for machines for common applications

Alongside generalized rules for terminal labelling, EN 60034-8:2002 also contains a wealth of connection diagrams for use in common applications.

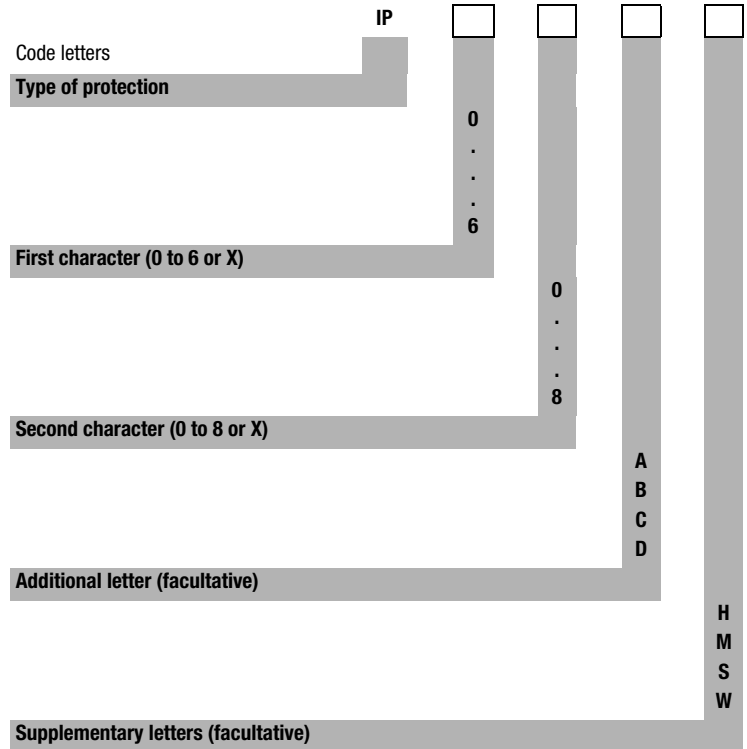


The new connection labelling to EN 60034-8:2002 will be phased-in beginning with orders received after 1st January 2005. There is no obligation to update machines delivered according to the old standard during servicing (to protect stocks).

A.5 Protection

A.5.1 Protection/ IP code to IEC/ EN

The category of protection provided by an enclosure is designated by an alphanumeric code (IP code). The explanatory notes on the IP code apply to the standard laid down in EN 60529/DIN VDE 0470, part 1.



Facultative additional letter: Additional letters are only used where:

1. the actual protection against touching dangerous parts is higher than that indicated by the first character, or
2. only protection against touching dangerous parts is specified and the first character is replaced by an X.

Component	Digits or letters	Meaning for protection of equipment	Meaning for protection of personnel
Code letters	IP	-	-
First code digit	0	Against intrusion of solid foreign bodies (not protected)	Against touching dangerous parts with (not protected)
	1	> 50 mm diameter	back of hand
	2	> 12.5 mm diameter	finger
	3	> 2.5 mm diameter	tool
	4	> 1.0 mm diameter	wire
	5	Dust-protected	wire
	6	Dust-tight	wire
Second code digit	0	Against intrusion of water with damaging effects (not protected)	-
	1	Vertical drips	-
	2	Drips (15° slant)	-
	3	Spray water	-
	4	Splash water	-
	5	Jet water	-
	6	Powerful jet water	-
	7	Temporary submersion	-
8	Permanent submersion	-	
Additional letter (facultative)	A	-	Against touching dangerous parts with back of hand
	B	-	finger
	C	-	tool
	D	-	wire
Supplementary letter (facultative)	H	Supplementary information specially for: high-voltage equipment	-
	M	movement during water testing	-
	S	standstill during water testing	-
	W	weather conditions	-

Table A.43 Meanings of the IP code digits and letters

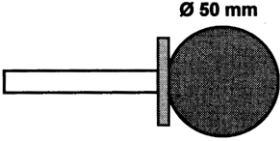
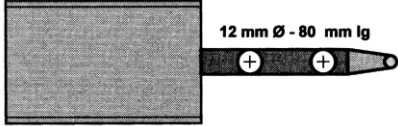
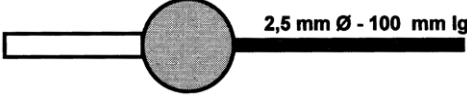
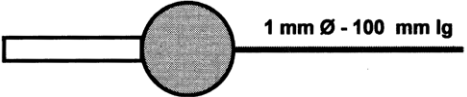
Protection against touching with	Probe	Explanation
Back of hand	 <p style="text-align: center;">$\text{Ø } 50 \text{ mm}$</p>	The plate between the sphere and handle is not a stop, but a guard for the tester.
Finger	 <p style="text-align: center;">$12 \text{ mm } \text{Ø} - 80 \text{ mm lg}$</p>	The "divided test finger" has two joints. In the IP test it is only to be used as far as the first contact area 50 mm x 20 mm after a length of 80 mm as shown in the diagram.
Tool	 <p style="text-align: center;">$2,5 \text{ mm } \text{Ø} - 100 \text{ mm lg}$</p>	The "contact area" is executed as a sphere of 35 mm diameter. It is intended to simulate the knuckle when the tool or wire is held in the hand.
Wire	 <p style="text-align: center;">$1 \text{ mm } \text{Ø} - 100 \text{ mm lg}$</p>	

Table A.44 Probes for testing of touch protection in the IP system


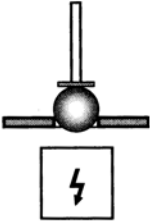

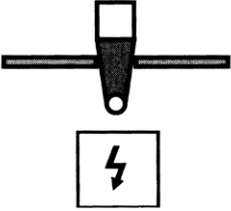

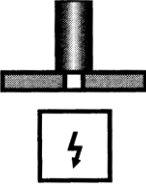

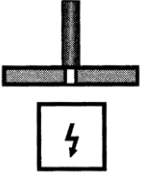
Degree of protection	Protection of personnel against access to dangerous parts	
IP1X	Back of hand 	
IP2X	Finger 	
IP3X	Tool 	
IP4X IP5X IP6X	Wire 	

Table A.45 Touch protection requirements for the first code digits

Degree of protection	Protection of the equipment against intrusion of dust ¹⁾
IP5X	Dust-protected: The intrusion of dust cannot be fully prevented, but dust must not intrude in quantities such as to impair the satisfactory operation of the equipment or safety.
IP6X	No dust must intrude into the equipment.
1) Dust protection test to EN 60529/DIN VDE 0470, part 1	

Table A.46 Dust protection requirements for the first code digits (5.6)

Degree of protection	Protection against	Test schematic
IPX1	Drip water	<p>1 mm / min 10 min</p>
IPX2	Drip water at a 15° slant	<p>3 mm / min 4 x 2,5 min 15°</p>

Table A.47 Water protection requirements for the second code digits IPX1 ... IPX8

Degree of protection	Protection against	Test schematic
IPX3	Spray water	
IPX4	Splash water	
IPX5	Jet water	<p> $qv = 12.5 \text{ l / min}$ $p \sim 0.3 \text{ bar}$ $t = 1 \text{ min / m}^2$ $> 3 \text{ min}$ </p>

Table A.47 Water protection requirements for the second code digits IPX1 ... IPX8

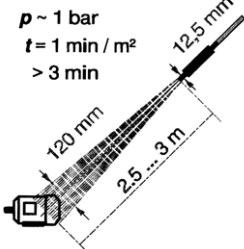
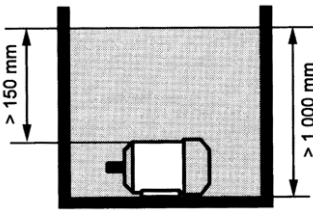
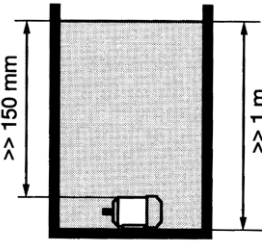
Degree of protection	Protection against	Test schematic
IPX6	Powerful jet water	<p> $qv = 100 \text{ l / min}$ $p \sim 1 \text{ bar}$ $t = 1 \text{ min / m}^2$ $> 3 \text{ min}$ </p> 
IPX7	Temporary immersion	<p>$t = 30 \text{ min}$</p> 
IPX8	Permanent immersion	<p>$t = \infty$ IPX8 > IPX7</p> 

Table A.47 Water protection requirements for the second code digits IPX1 ... IPX8

A.5.2 Protection to EEMAC and Nema

Types of protection of electrical equipment for USA and Canada conforming to IEC 529/EN 60529, VDE 0470 part 1

The IP protection types quoted represent a rough comparison. A detailed comparison is not possible, because protection tests and assessment criteria differ.

Marking of the housing and the protection type		Marking of the housing and the protection type to CSA-C22.1 (Canadian Electrical Code) CSA-C22.2 No. 94	Comparable IP protection to IEC 529/ DIN 40050
to NEC NFPA 70 (National Electrical Code) to UL 508 to NEMA No. 250-1985	to NEMA ICS6-19831 to EEMAC E 14-22)		
Enclosure type 1	Enclosure type 1 General purpose	Enclosure 1 Enclosure for general purposes	Ip 20
Enclosure type 2 Drip-tight	Enclosure type 2 Drip-proof	Enclosure 2 Drip-proof enclosure	IP 22
Enclosure type 3 dust-tight, rain-tight	Enclosure type 3 R Dust-tight, rain-tight, resistant to sleet and ice	Enclosure 3 Weather-proof enclosure	IP 54
Enclosure type 3 R Rain-proof	Enclosure type 3 R Dust-tight, rain-tight, resistant to sleet and ice		
Enclosure type 3 S Dust-tight, rain-tight	Enclosure type 3 S Dust-tight, rain-tight, resistant to sleet and ice		
Enclosure type 4 Rain-tight, water-tight	Enclosure type 4 Dust-tight, water-tight	Enclosure 4 Water-tight enclosure	IP 65
Enclosure type 4 X Rain-tight, water-tight, corrosion-resistant	Enclosure type 4 X Dust-tight, water-tight, corrosion-resistant		
Enclosure type 6 Rain-tight	Enclosure type 6 Dust-tight, water-tight, submersible, resistant to sleet and ice		

Table A.48 Protection types of electrical equipment for USA and Canada

Marking of the housing and the protection type to NEC NFPA 70 (National Electrical Code) to UL 508 to NEMA No. 250-1985	to NEMA ICS6-19831) to EEMAC E 14-22)	Marking of the housing and the protection type to CSA-C22.1 (Canadian Electrical Code) CSA-C22.2 No. 94	Comparable IP protection to IEC 529/ DIN 40050
Enclosure type 6 P Rain-tight, corrosion- resistant			
Enclosure type 11 Drip-tight, corrosion- resistant	Enclosure type 11 Drip-proof, corrosion- resistant, oil-submersed		
Enclosure type 12 Dust-tight, drip-tight	Enclosure type 12 Use in industry, drip- tight, dust-tight	Enclosure 5 Dust-tight enclosure	IP 54
Enclosure Type 12 K (as for type 12)			
Enclosure type 13 Dust-tight, drip-tight	Enclosure type 13 Dust-tight, oil-tight		

Table A.48 Protection types of electrical equipment for USA and Canada

- 1) NEMA= National Electrical
Manufacturers Association
- 2) EEMAC= Electrical and Electronic
Manufacturers Association
of Canada

Terms in German/English:

allgemeine Verwendung:	general purpose
tropfdicht:	drip-tight
staubdicht:	dust-tight
regendicht:	rain-tight
regensicher:	rain-proof
wettersicher:	weather-proof
wasserdicht:	water-tight
eintauchbar:	submersible
eisbeständig:	ice-resistant
hagelbeständig:	sleet-resistant
korrosionsbeständig:	corrosion-resistant
öldicht:	oil-tight

A.5.3 Cable glands with PG/metric thread

Technical data for installation

PG thread DIN40430	Nominal thread			
	d1	d2	P	d3
PG7	11.28	12.50	1.27	13.0 ±0.2
PG9	13.35	15.20	1.41	15.7 ±0.2
PG11	17.26	18.60	1.41	19.0 ±0.2
PG13.5	19.06	20.40	1.41	21.0 ±0.2
PG16	21.16	22.50	1.41	23.0 ±0.2
PG21	26.78	28.30	1.588	28.8 ±0.2
PG29	35.48	37.00	1.588	37.5 ±0.3
PG36	45.48	47.00	1.588	47.5 ±0.3
PG42	52.48	54.00	1.588	54.5 ±0.3
PG48	57.73	59.30	1.588	59.8 ±0.3
Metric thread DIN 46319	Nominal thread			
	d1	d2	P	d3
M 12 x 1.5	10.38	12	1.5	12.5 ±0.2
M 16 x 1.5	14.38	16	1.5	16.5 ±0.2
M 20 x 1.5	18.38	20	1.5	20.5 ±0.2
M 25 x 1.5	23.38	25	1.5	25.5 ±0.2
M 32 x 1.5	30.38	32	1.5	32.5 ±0.2
M 40 x 1.5	38.38	40	1.5	40.5 ±0.3
M 50 x 1.5	48.38	50	1.5	50.5 ±0.3
M 63 x 1.5	61.38	63	1.5	64.0 ±0.3
Metric thread DIN 89 280	Nominal thread			
	d1	d2	P	d3
M 18 x 1.5	16.38	18	1.5	18.5 ±0.2
M 24 x 1.5	22.38	24	1.5	24.5 ±0.2
M 30 x 2.0	27.34	30	2.0	30.5 ±0.2
M 36 x 2.0	33.34	36	2.0	36.5 ±0.2
M 45 x 2.0	42.34	45	2.0	45.5 ±0.3
M 56 x 2.0	53.34	58	2.0	57.0 ±0.3
M 72 x 2.0	68.82	72	2.0	73.0 ±0.3
d1 = core diameter		d3 = drill hole diameter		
d2 = outer diameter		p = pitch		

Table A.49 Technical data for installation

A.5.4 Outer diameters of wires and cables

Number of conductors	Approximate outer diameter (average of multiple makes)				
	NYM	NYY	H05 RR-F	H07 RN-F	NYCY NYCWY
Cross-section mm ²	mm max.	mm	mm max	mm max.	mm
2 x 1.5	10	11	9	10	12
2 x 2.5	11	13	13	11	14
3 x 1.5	10	12	10	10	13
3 x 2.5	11	13	11	12	14
3 x 4	13	17	-	14	15
3 x 6	15	18	-	16	16
3 x 10	18	20	-	23	18
3 x 16	20	22	-	25	22
4 x 1.5	11	13	9	11	13
4 x 2.5	12	14	11	13	15
4 x 4	14	16	-	15	16
4 x 6	16	17	-	17	18
4 x 10	18	19	-	23	21
4 x 16	22	23	-	27	24
4 x 25	27	27	-	32	30
4 x 35	30	28	-	36	31
4 x 50	-	30	-	42	34
4 x 70	-	34	-	47	38
4 x 95	-	39	-	53	43
4 x 120	-	42	-	-	46
4 x 150	-	47	-	-	52
4 x 185	-	55	-	-	60
4 x 240	-	62	-	-	70
5 x 1.5	11	14	12	14	15
5 x 2.5	13	15	14	17	17
5 x 4	15	17	-	19	18
5 x 6	17	19	-	21	20

Table A.50 Diameters of wires and cables

Number of conductors	Approximate outer diameter (average of multiple makes)				
	NYM	NYY	H05 RR-F	H07 RN-F	NYCY NYCWY
Cross-section mm ²	mm max.	mm	mm max	mm max.	mm
5 x 10	20	21	-	26	-
5 x 16	25	23	-	30	-
8 x 1.5	-	15	-	-	-
10 x 1.5	-	18	-	-	-
16 x 1.5	-	20	-	-	-
24 x 1.5	-	25	-	-	-

Table A.50 Diameters of wires and cables

NYM: Sheathed cable
 NYY: Cable with plastic sheath
 H05RR-F: Light rubber hose
 (NLH + NSH)

NYCY: Cable with concentric conductor and plastic sheath
 NYCWY: Cable with concentric corrugated conductor and plastic sheath

A.5.5 Current capacity of PVC-insulated copper wires

Cross-section mm ²	Layout methods			
	B1	B2	C	E
	Current capacity I _z			
0.75	7.6	-	-	-
1.0	10.4	9.6	11.7	11.5
1.5	13.5	12.2	15.2	16.1
2.5	18.3	16.5	21	22
4	25	23	28	30
6	32	29	36	37
10	44	40	50	52
16	60	53	66	70
25	77	67	84	88
35	97	83	104	114
50	-	-	123	123
70	-	-	155	155
95	-	-	192	192
120	-	-	221	221
Electronics (pairs)				
0.2	-	-	4.0	4.0
0.3	-	-	5.0	5.0
0.5	-	-	7.1	7.1
0.75	-	-	9.1	9.1
<ul style="list-style-type: none"> • For ambient temperatures differing from +40 °C the current capacities should be corrected by the values in Table A.52. • These values are not applicable to flexible reeled cables. • For the current capacities of other cables and wires refer to IEC 60364-5-523. 				

Table A.51 Current capacity

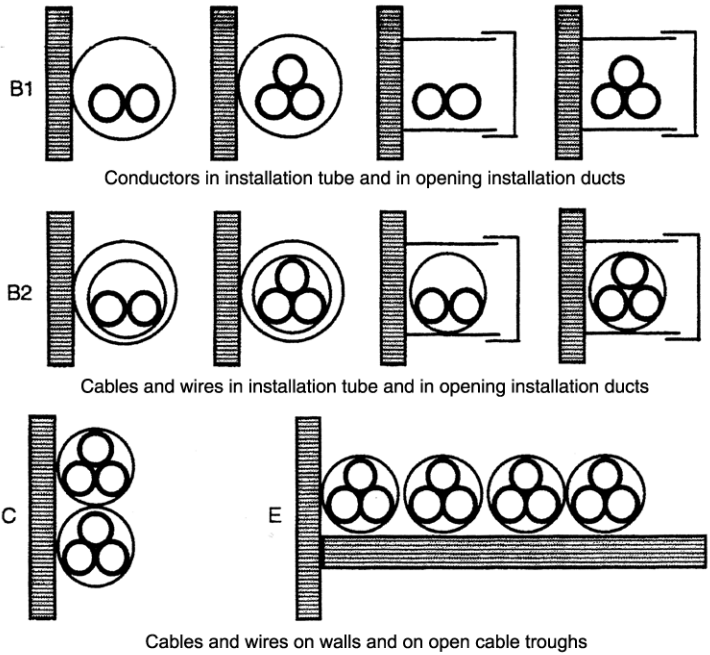


Figure 1.24 Methods of conductor, cable and wire laying

Ambient air temperature °C	Correction factor
30	1.15
35	1.08
40	1.00
45	0.91
50	0.82
55	0.71
60	0.58

NOTE: The correction factors are taken from IEC 60364-5-523, Table 52-D1.

Table A.52 Ambient temperature correction factors

A.5.6 Colour coding for pushbuttons/controls

Colour	Meaning	Explanation	Application examples
RED	Emergency	Operate in a hazardous state or in case of emergency	Shutdown in emergency; initiate emergency functions (see also 10.2.1)
YELLOW	Abnormal	Operate in an abnormal state	Intervene to suppress an abnormal state. Intervene to restart an interrupted automatic process.
GREEN	Normal	Operate to initiate normal states	
BLUE	Essential	Operate in a state requiring an essential action	Reset function
WHITE	No specific meaning assigned	For general initiation of functions except emergency shutdown (see Note)	START/ON (preferred) STOP/OFF
GREY			START/ON STOP/OFF
BLACK			START/ON STOP/OFF (preferred)
NOTE: Where an additional coding aid (e.g. shape, position, surface quality) is used to identify pushbuttons/controls, the same colours WHITE, GREY or BLACK may be used for different functions (e.g. WHITE for START/ON and STOP/OFF controls).			

Table A.53 Colour coding for pushbuttons/controls

A.5.7 Colours of indicator lights

Colour	Meaning	Explanation	Operator action
RED	Emergency	Hazardous state	Immediate action to respond to a hazardous state (e.g. by activating emergency shutdown)
YELLOW	Abnormal	Abnormal state; impending critical state	Monitor and/or intervene (e.g. by restoring the intended function)
GREEN	Normal	Normal state	Optional
BLUE	Essential	Display of a state requiring action by the operator	Essential action
WHITE	Neutral	Other states; may be used in case of doubts as to the use of RED, YELLOW, GREEN or BLUE	Monitor

Table A.54 Colours of indicator lights



Flash signals

For further differentiation or as additional information and to highlight something further, flashing lights may be used for the following purposes:

- To attract attention
- To provoke immediate action
- To indicate a difference between a required and an actual state
- To indicate a change in a process (flashing during a transition)

It is recommended that the more important information be assigned the fast flash rates (see IEC 60073 for recommended flash rates and pulse/pause ratios).

A.5.8 Standardized Transverse section of round conductors (ISO/AWG)

ISO - transverse section mm ²	AWG / MCM	
	size	Equivalent transverse section mm ²
0,2	24	0,205
-	22	0,324
0,5	20	0,519
0,75	18	0,82
1,0	-	-
1,5	16	1,3
2,5	14	2,1
4,0	12	3,3
6,0	10	5,3
10	8	8,4
16	6	13,3
25	4	21,2
35	2	33,6
50	0	53,5
70	00	67,4
95	000	85,0
-	0000	107,2
120	250 MCM	127
150	300 MCM	152
185	350 MCM	177
240	500 MCM	253
300	600 MCM	304

Tabelle A.55 Transverse section of round conductors

Appendix B Practical working aids for the project engineer

1

2

3

4

5

6

A

Recording of movement task	Project name: _____
<p>Company: _____ Name/function: _____ _____ _____</p> <p>Sector/application: _____</p> <p>Goal: _____ _____ _____</p> <p>Special conditions: _____ _____ _____ _____</p> <p>Comments: _____ _____ _____ _____</p> <p>Author: _____ Date: _____ Page of</p>	

<h2 style="text-align: center; margin: 0;">Movement requirements for processing</h2>	Project name: _____ _____
<div style="display: flex; justify-content: space-around; margin-bottom: 20px;"> <div style="text-align: center;"><input type="checkbox"/> Continuous material flow</div> <div style="text-align: center;"><input type="checkbox"/> Discontinuous batch process</div> <div style="text-align: center;"><input type="checkbox"/> Discontinuous unit process</div> </div> <div style="text-align: center; margin-bottom: 20px;"> </div> <div style="display: flex; justify-content: space-around; margin-bottom: 20px;"> <div style="text-align: center;"><input type="checkbox"/> Rotational movement $[n=f(t)]$</div> <div style="text-align: center;"><input type="checkbox"/> Translational movement $[v=f(t)]$</div> </div> <p>Radius of drive shaft via which movement is generated _____ mm</p> <p>Comments: _____ _____ _____</p> <p>Author: _____ Date: _____ Page of</p>	



Movement requirements for processing	Project name: _____
Moment: _____ [kgm ²] of inertia	oder Mass: _____ [kg] Movement type: _____ _____
Speed manipulating range: _____ Static speed accuracy: _____ [rpm] Dynamic speed accuracy: _____ [rpm]	Torque rise time: _____ [ms] Positioning accuracy: _____ [ms]
Comments: _____ _____ _____	
Load torque of processing process <input type="checkbox"/> $M_L \sim 1/n, P = \text{constant}$ <input type="checkbox"/> $M_L = \text{constant}, P \sim n$ <input type="checkbox"/> $M_L = f(n), P = f(n)$ <input type="checkbox"/> $M_L \sim n^2, P \sim n^3$ <input type="checkbox"/> $M_L = f(n)$ <input type="checkbox"/> $M_L = f(s)$ <input type="checkbox"/> $M_L = f(\alpha)$ <input type="checkbox"/> $M_L = f(t)$	
Author: _____ Date: _____ Page of	

Further data from the environment	Project name: _____
<p>Automation process: _____ _____ _____ _____</p> <p>Environment and installation environment: _____ _____ _____ _____</p> <p>Standards, regulations and safety: _____ _____ _____ _____</p> <p>Author: _____ Date: _____ Page of</p>	

1

2

3

4

5

6

A

Appendix C Bibliography and source references

Bibliography and source references for section 1

Das 1x1 der Antriebstechnik

Friedrich Wilhelm Garbrecht - Joachim Schäfer
ISBN 3-8007-2005-1
VDE-Verlag

Projektmanagement

J. Boy - C. Dudek - S. Kuschel
ISBN 3-930799-01-4
Gabal

Positionieren mit Antriebsreglern durch Echtzeitverarbeitung, Teil 1

Joachim Schäfer
Specialist article in "Antriebstechnik" 1991, no. 3

Positionieren mit Antriebsreglern durch Echtzeitverarbeitung, Teil 2

Joachim Schäfer
Specialist article in "Antriebstechnik" 1991, no. 5

Produkt- und Anlagenoptimierung

Wolfram Fischer, Wilhelm Dangelmaier
ISBN 3-540-66577-3
Springer Verlag

Montage strategisch ausrichten

Praxisbeispiel marktorientierter Prozesse und Strukturen
K. Feldmann, H.-J. Gergs, S. Slama, U. Wirth
ISBN 3-540-40304-3

Motion Control

Peter F. Brosch
ISBN 3-478-93285-8
Verlag Moderne Industrie

Drehzahlvariable Antriebe für die Automatisierung

Peter F. Brosch
ISBN 3-8259-1904-8
Vogel Verlag

Visualisieren Präsentieren Moderieren

Josef W. Seifert
ISBN 3-930799-00-6
Gabal Verlag

Modularisierung von Produkten

Marc Müller
Hanser Verlag

Bibliography and source references for section 2**Der Drehstrommotor**

Karl Falk
ISBN 3-8007-2078-7
VDE - Verlag

Grundlagen der elektrischen Antriebstechnik mit Berechnungsbeispielen

Johannes Vogel
ISBN 3-7785-1547-0
VEB Verlag Technik

Dynamische Eigenschaften von Drehstrom-Motoren

Joachim Schäfer
Specialist article in AGT 1994, no. 2

Elektromaschinen und Antriebe

Yearbook 2004
Dipl. Ing. Volkmar Christner
Hüthig & Pflaum Verlag
ISBN 3-8101-0181-8

Schutzmaßnahmen bei Drehstromantrieben

Dipl. Ing. Helmut Greiner
Hüthig Verlag Heidelberg
ISBN 3-7785-2730-4

Präzisions-Getriebe für die Automation

Christian Mayr
ISBN 3-478-93032-4
Verlag Moderne Industrie

Getriebemotoren

Franz Josef Mack, Michael Wagner-Ambis
ISBN 3-478-93095-2
Verlag Moderne Industrie

**Datenschnittstellen der HEIDENHAIN-Geräte
Service manual**

Dr. Johannes Heidenhain GmbH
<http://www.heidenhain.de>

**Messgeräte für elektrische Antriebe
Product catalogue**

Dr. Johannes Heidenhain GmbH
<http://www.heidenhain.de>

Drehgeber**Product catalogue**

Hengstler GmbH, Aldingen

<http://www.hengstler.de>

Sensortechnik - Drehgeber und lineare Messtechnik**Product catalogue**

Fritz Kübler GmbH, Villingen-Schwenningen

<http://www.kuebler.com>

Synchron serielles Interface für absolute Winkelcodierer**Product information**

Max Stegmann GmbH Antriebstechnik, Donaueschingen

<http://www.stegmann.de>

Motorfeedback-Systeme für Servomotoren**SinCos® SRS/M 50 / SRS/M 60 (HIPERFACE® kompatibel)****Product information**

Max Stegmann GmbH Antriebstechnik, Donaueschingen

<http://www.stegmann.de>

Modulares Antriebssystem MAS 2000

WATTDRIIVE Antriebstechnik, A-Markt Piesting

<http://www.wattdrive.com>

Antriebskatalog

ABM Greifenberger, Marktredwitz

<http://www.abm-antriebe.de>

Bibliography and source references for section 3**Feldschwächung bei Antriebsreglerantrieben bietet viele Vorteile**

Joachim Schäfer

Specialist article in "Antriebstechnik" 36 (1997) no. 4

Moderne Stromrichterantriebe

Peter F. Bosch

ISBN 3-8023-0241-9

Vogel Verlag

Feldbussysteme im Vergleich

Robert Busse

ISBN 3-7905-0722-9

Pflaum Verlag

Positionieren mit Antriebsreglern durch Echtzeitverarbeitung, Teil 1

Joachim Schäfer

Specialist article in "Antriebstechnik" 1991, no. 3

Positionieren mit Antriebsreglern durch Echtzeitverarbeitung, Teil 2

Joachim Schäfer

Specialist article in "Antriebstechnik" 1991, no. 5

ZVEI research report: "Elektrische Belastung und Ausfallverhalten der Wickelisolierung von Asynchronmaschinen mit Antriebsreglerbetrieb".

Berth, Eberhardt, Kaufhold, Speck, Auinger

Elektrie, H.8/9 (1995) p. 336

Frequenzumformer

Dr. Ing. P. F. Brosch

ISBN 3-478-93036-7

Verlag Moderne Industrie

Drehzahlvariable Antriebe für die Automatisierung

Peter F. Brosch

ISBN 3-8259-1904-8

Vogel Verlag

Tagungsbänder SPS/IPC/DRIVES

Elektrische Automatisierung

Publisher: Fraunhoferinstitut Stuttgart, TU Munich

Hütting Verlag

Motion Control

Peter F. Brosch

ISBN 3-478-93285-8

Verlag Moderne Industrie

Bibliography and source references for section 4**Oberschwingungen**

Albert Kloss
ISBN 0175-9965
VDE-Verlag

Frequenzumformer

Dr. Ing. P. F. Brosch
ISBN 3-478-93036-7
Verlag Moderne Industrie

Elektronische Gerätetechnik

Prof. Dipl.-Ing. Hans Brümmer
ISBN 3-8023-0610-4
Vogel-Verlag

Netzurückwirkungen**Hormann/Just/Schlabbach**

Anlagentechnik für elektrische Verteilungsnetze (vol. 14)
Rolf R. Cichowski (publ.)
ISBN 3-8022-2231-3
VDE-Verlag

EMV-Fibel**für Elektroinstallateure und Planer**

Wilhelm Rudolph
ISBN 3-8007-2613-0
VDE - Verlag

**Grundsätze zur Beurteilung
von Netzurückwirkung**

ISBN 3-8022-0311-9
VWEW Verlag

EMV nach VDE 0100

VDE series, volume 66
VDE-Verlag

ZVEI

EMV-Leitfaden
Elektrische Antriebe
www.zvei.de/antriebe

Bibliography and source references for section 5**Oberschwingungen**

Albert Kloss
ISBN 0175-9965
VDE-Verlag

Absicherung von Maschinen vor gefährbringenden Bewegungen

Sicherheitsbezogene Teile von Maschinensteuerungen
Elan Schaltelemente GmbH & Co. KG
D-35435 Wetztenberg
www.elan.de

Schutztechnik mit Isolationsüberwachung

Wolfgang Hofheinz
ISBN 3-8007-2215-1
VDE-Verlag

Schaltschrank Klimatisierung

Heinrich Styppa
ISBN 3-478-93080-4
Verlag Moderne Industrie

Elektronische Gerätetechnik

Prof. Dipl.-Ing. Hans Brümmer
ISBN 3-8023-0610-4
Vogel-Verlag

Netzzrückwirkungen**Hormann/Just/Schlabbach**

Anlagentechnik für elektrische Verteilungsnetze (vol. 14)
Rolf R. Cichowski (publ.)
VDE-Verlag, ISBN 3-8022-2231-3

EMV-Fibel**für Elektroinstallateure und Planer**

Wilhelm Rudolph
ISBN 3-8007-2613-0
VDE-Verlag

Elektroinstallation und Betriebsmittel in explosionsgefährdeten Bereichen

Heinz Olenik u.a.
ISBN 3-8101-0130-3
Hüthig & Pflaum Verlag

Fehlerstrom Überwachung in elektrischen Anlagen

Wolfgang Hofheinz
ISBN 3-8007-2422-7
VDE-Verlag

Dipl.-Ing. W. Bender GmbH & Co. KG

Londorfer Straße 65
35305 Grünberg
www.bender-de.com

ZVEI Automation

Anforderungen an moderne Steuerungssysteme für
Sicherheitsangaben an Maschinen
Neue Anschlusskennzeichnungen für drehende elektrische Maschinen
www.zvei.org

**Grundsätze zur Beurteilung
von Netzurückwirkung**

ISBN 3-8022-0311-9
VWEW Verlag

EMV nach VDE 0100

VDE series, volume 66
VDE-Verlag

ZVEI

EMV-Leitfaden
Elektrische Antriebe
www.zvei.de/antriebe

ELAN - Vortragsveranstaltungen 2005

Sicherheitsbezogene Teile von Maschinensteuerungen
Elan Schaltelemente GmbH & Co. KG
D-35435 Wettenberg
www.elan.de

Bibliography and source references for section 6**Das 1x1 der Antriebstechnik**

Friedrich Wilhelm Garbrecht - Joachim Schäfer

ISBN 3-8007-2005-1

VDE-Verlag

Elektrische Antriebstechnik

Heinz Stüben

ISBN 3-7736-0839-x

Verlag W. Girardet

Grundlagen der elektrischen Antriebstechnik mit Berechnungsbeispielen

Johannes Vogel

ISBN 3-7785-1547-0

VEB Verlag Technik

Bibliography and source references for Appendix**Das 1x1 der Antriebstechnik**

Friedrich Wilhelm Garbrecht - Joachim Schäfer
ISBN 3-8007-2005-1
VDE-Verlag

Taschenbuch der Technik

T. Krist
ISBN 3-87807-124-8
Technik-Tabellen-Verlag

Der Drehstrommotor

Karl Falk
ISBN 3-8007-2078-7
VDE - Verlag

Elektrische Antriebstechnik

Heinz Stüben
ISBN 3-7736-0839-x
Verlag W. Girardet

Moderne Stromrichterantriebe

Peter F. Bosch
ISBN 3-8023-0241-9
Vogel Verlag

Klöckner Moeller Schaltungsbuch

Klöckner Moeller, Bonn

Elektromaschinen und Antriebe

Yearbook 2004
Dipl. Ing. Volkmar Christner
ISBN 3-8101-0181-8
Hüthig & Pflaum Verlag

**Schutzmaßnahmen
bei Drehstromantrieben**

Dipl. Ing. Helmut Greiner
ISBN 3-7785-2730-4
Hüthig Verlag Heidelberg

Präzisions-Getriebe für die Automation

Christian Mayr
ISBN 3-478-93032-4
Verlag Moderne Industrie

Getriebemotoren

Franz Josef Mack, Michael Wagner-Ambis

ISBN 3-478-93095-2

Verlag Moderne Industrie

DIN EN 61800-5-1**VDE 0160 Teil 105**

Elektrische Leistungsantriebssysteme mit einstellbarer Drehzahl

1

2

3

4

5

6

A

Appendix D Index

Numerics

70 Hz characteristic with 25% field weakening ..	110
87 Hz characteristic / Expanded manipulating range	114

A

Abbreviations	22
Abbreviations used	22
Absolute encoders	66
AC-3 contactor	39
Acceleration behaviour of standard three-phase AC motors	16
Acceleration times	17, 20
Acceptance tests/Ambient conditions	5
Accuracy of position control depending on the encoder system	23
Accuracy of speed control depending on the encoder systems	19
Actual position and tracking errors	62
Actual speed filter	61
Advanced project planning	24
Advanced project planning rule	20
Advantages of using drive controllers with "Safe Standstill"	62
All-current sensitive fault current breaker monitoring (RCM) in earthed systems	84
All-current sensitive residual current monitoring in passenger and goods lifts	87
Ambient temperature, mounting type and installation altitude	6
Amplitude	72
Ancillary equipment	88
Application of future norms	67
Approximation calculus	38
Areas of application for three-phase AC motors ..	101
Areas of application of servomotors	45
Areas of application of special three-phase AC motors	45

Assignment of drive controllers with external mains filter	6
Asynchronous servomotors, forced cooling	77
Asynchronous servomotors, self cooling	77
Autotransformer	37
Axial and radial forces	90

B

Basic configuration of LSH servomotors	23
Basic measurement method for RCMs/RCDs	84
Basic physical equations	6
Basic principle of position control in the c-line drive controller	23
Basic principle of sensorless Flux Control (SFC)	44
Basic principle of torque, speed and position control	58
Basic terms for calculation	3
Basics of closed-loop control	48
Bearing currents	46
Bearing stress in drive controller operation	46
Benefits of a three-phase line choke	4
Block diagram of a drive controller with braking chopper	8
Block diagram of a voltage transformer	35
Block diagram of control circuit	42
Block diagram, HTL output circuit	122
Blowers, fans, centrifugal pumps	30
Braking resistor	8
Break-away and acceleration torques	105
Burst and surge on mains line	38
Burst on signal and data lines	39

C

Cable glands	100
Cable length, current and voltage losses	41
Calculate gross output	3
Calculating the key application data	6
Calculation	12

Effective braking power	11
Effective drive controller capacity utilization ...	47
Effective switch cabinet surface power output .	5
Heat exchangers	8
of filter fans	7
Peak braking power	13
Calculation example with CDA34.014, C	11
Calculation factor for filter fans	7
CE mark	5
Change in system load	23
Change in system load resulting from insertion of a line choke with 4% short-circuit voltage based on the example of a 4 kW drive controller	5
Characteristic	
Operation modes	22
Characteristic values	
of LSH servomotors	21
of machinery	10
of planetary gears	91
of reluctance motors	46
of standard gears	84
of standard three-phase AC motors	8
Characteristic values of high-frequency motors ...	53
Characteristic values of motor brakes	94
Characteristic values of synchronous motors with damper cage	50
Choice of braking resistor	12
Choice of max. acceleration	19
Choking factors	24
Circuitry example - DC network operation with c-line drive controller	51, 63
Circuitry example "Switching at the drive controller output"	38
Circular graduations and photoelectric measuring principle for incremental encoders	60
Circumferential backlash	92
Classification and colour coding of the nominal response temperature to DIN44081	69
c-line	
Drive controller system	97
Drive controllers	1, 3
Positioning drive	145
c-line Drives drive controllers	3
c-line servo and direct drive controllers	149
Clockwise/anti-clockwise	37

Closed-loop control functions of the drive controller without speed feedback	43
Closed-loop processes	127
Code disk and photoelectric measuring principle ..	67
Coefficients for rim and side friction	33
Coefficients of friction	
for roller bearing friction	33
Coefficients of friction for bearing friction	33
Coefficients of friction for spindles	33
Coefficients of friction of various material pairings	34
Colour coding for pushbuttons/controls	105
Colour coding of a threshold value PTC	69
Colours of indicator lights	106
Combined method	63
Comparison between old solution and solution from functional analysis	7
Comparison of gear output torques in drive designs with 50 Hz and 70 Hz characteristic	112
Comparison of solutions	
"Functional analysis/Process analysis"	9
Compensation with harmonic generator	25
Connection example	121
Connection example for currentless switching	39
Connection example for ENMO	39
Connection of sensor cables	82
Control quality	55
Control structure in the servocontroller	58
Control terminal assignment, rotational drive with encoder evaluation	121
Controlled system	48
Controller	52
Controller optimization	59
Conventional NC functionality for machine tools ...	26
Conversion	
Translation into rotation	26
Translation into rotation multi-motor	26
Conveyor belt in acceleration phase with a vessel filled with liquid	20
Conveyor belt with a high body and small standing area	19
Conveyor belt with unsecured object during acceleration	19
Conveyors such as inclined lifts	31
Cooling methods	11
Cooling of LSH servomotors	24
Correction factors	104

CSA Certification	27
cUL acceptance	27
cUL approbation	5
Current capacity	103
Multi-wire cables	24
of positioning drives CDE/CDB3000	145
Current capacity of drive controllers CDA3000	97
Current capacity of PVC-insulated copper wires ..	103
Current capacity of servo and direct drive controllers	149
Current curve with controlled diode bridge	17
Current load capacity of multi-wire cables	24

D

Data comparison of reluctance design against asynchronous design	48
Data for commissioning and tests	57
Data transfer with the SSI absolute encoder	68
DC link capacitors	35
DC network operation	51, 63
DC network operation with PTC precharging circuit	66
Definitions of lateral forces	36
Density of various materials	34
Dependencies of the motor variables in drive controller operation (open loop)	12
Description of safety categories	51
Design of cable cross-sections	30
Design of LSH servomotors	24
Detailing of direction of rotation	89
Determine power requirement to move the application	3
Determining the drive torque	87
Diagram	128
Diagram for service factors	87
Diagram of PTC KTY 84-130	72
Direction of rotation	37
Direction of rotation and terminal designation	37
Drill feed unit	130, 131
Drive capacities in process engineering	11
Drive controller	39
Drive controller fed power drives	76
Drive controller rating plate with year and month identification	36
Drive controllers	

for 230 V systems	97
for 400/460 V systems	98
Drive definition	
via LuDriveplus PC program	6
via power rating	2
Drive design with 50 Hz	110
Drive design with 70 Hz	111
Drive engineering equations	6
Drive system	3
Dynamic speed accuracy	20

E

Effect of the line choke with asymmetrical mains voltage based on the example of a 4 kW drive controller	5
Effective drive controller load	52
Effective braking power	11
Effective drive controller capacity utilization	47
Effective moment	18
Effective motor torque/power output	16
Effective switch cabinet surface	5
Effective torques of motors	5
Effective value method for internally cooled standard three-phase AC motors	18
Efficiencies of transmission elements	32
Efficiencies, coefficients of friction and density	32
Efficiency with standard three-phase AC motor	103
Efficiency of the motor control methods of the CDA3000	103
Electrical specification of the RS422 interface on the c-line Drives drive controller	81
Electromagnetic compatibility	6
Electromagnetic compatibility (EMC) and power drives	26
Electronic cam plate	28
Electrostatic discharge (ESD), contact discharge ...	39
EMC acceptance tests	5
EMC standardization of power drives	27
Encoder selection FOR mode with CDA3000	120
Encoder systems for c-line Drives	73
Encoder/motor assignment	73
Encoders with SSI interface	67

Energy	14
Equivalent circuit diagram with total loss balance	11
Evaluation	
Incremental encoders	62
of encoders with c-line Drives	75
Evaluation of sine/cosine encoders	65
Example	
Process analysis	5
Three-phase bridge	19
Two-conductor arrangement of a temperature sensor	89
Example 1	
Traction drive	3
Example 2	
Lifting drive	5
Example of a conversion	
to another motor characteristic	37
Example of conversion to different motor characteristic	37
Extruders	5, 29

F

Fault current monitoring in electrical installations with power drive systems	82
Fault currents without zero crossing	85
Field bus positioning	25
Field-Oriented Regulation (FOR)	103
Flash signals	106
Flux in the gear	86
Forming of the DC link capacitors	35
Forming of the DC link capacitors (ELKOS)	36
Free field measurement of RFI field strength	40
Friction	15
Functional analysis	7
Functions of the control loop	48

G

General	
EN 60034-8	87
General aspects of motor selection	2
General drive capacity	7
General power connections	24
General technical data	19
Geometric symbols	3
Guidelines and EN norm group	48

H

Hardware of the RS422 interface	80
Heat discharge from the switch cabinet	3
Heat transfer by conduction	9
HF injection on lines (picture taken from test report P030941)	38
High-voltage test/Insulation test	34
Hiperface	70
HTL signals with zero track	61

I

I/O oriented processes	126
Important units	5
Impulse torques	91
Incremental encoders	59
Indexing table with eccentric loads	27
Inductance per choke phase	38
Inductive resistance	38
Influence of ambient temperature	2
Influence of installation altitude	3
Installation guidelines for switch cabinets	41
Installation of encoders	73
Intended use	14
Interfaces	80
interference emission	36
Interference immunity	35
Interference spectrum	
of a 50 metre screened motor cable	27
of a 50 metre unscreened motor cable	28
Interlinking of block diagram elements	57
Internal torque	47
IP code digits and letters	92
IT, TN and TT systems	16

L

Lateral forces	36
Layout methods	104
Leakage current of 1-phase drive controllers	33
Leakage current of 3-phase drive controllers	33
Leakage currents	32
Leakage currents of the drive controllers	32
Lever arm of rolling friction for various material pairings	34
Lifting gear, conveyor systems, piston compressors, rolling mills	29

Limit speed of a standard three-phase AC motor	9
Limit temperature of the insulating material	67
Limit temperatures of electrical machines of protection categories "e" and "d"	78
Line choke	2, 38
Line choke to conform to EN 61000-3-2	7
Linear PTC KTY-130-gel	72
Load characteristic	
Blowers, fans, centrifugal pumps	30
Conveyors	31
Extruders	29
Machining centres	32
Mills	30
of the plastics extruder	6
Piston machines, eccentric presses, metal cutters	31
Load torque	29
Loading on the supply system	23
Loop control	40
Low motor losses	143

M

M/t diagram	89
Machining centres	32
Mains filter	14
Mains power cable	25
Manipulating range and accuracy	14
Mass moments of inertia	22
Mass moments of inertia of bodies	22
Mathematical symbols	3
Max. acceleration times of four-pole standard three-phase AC motors	17
Max. permissible amplitudes of current harmonics	7
Maximum permissible motor torque	3
Measurement on the drive controller	49
Measurement set-up	32, 27
Measurement set-up for acceptance testing of power drives	35
Measures for your safety	13
Measures to maintain UL approbation	29
Measuring circuit for a voltage drive controller	50
Mills	30
Minimum cross-section of the grounding lead	26
Minimum speeds when using encoders with differing lines per revolution	124

M-n characteristic for asynchronous motors	18
M-n characteristic for synchronous servomotors	22
M-n characteristic of a synchronous servomotor	4
M-n characteristic of a three-phase AC motor	4
Modern-day movement control	24
Modular heat sink concept	11
Moment of inertia	13
Motor choke	19
Motor data	
of asynchronous servomotors	77
of EUSA system motors	80
of slim-line three-phase AC motors made of extruded aluminium section	85
of standard three-phase AC motors	74
Motor filter	22
Motor protection possibilities	45, 73
Motor selection	6
Motors	67
Motors of protection category "d"	77
Mounting of externally mounted encoders	73
Movement	
by cable reel	25
by conveyor roller	24
by rack	25
by spindle	25
Movement requirement	10
Movement solution	
Traction and mechanical function	12
Movement solution in the processing process	11
Multi-motor operation on one drive controller	117
Multiple Listing	27
Multi-wire cables	24

N

New connection markings for rotating electrical machines	87
Norm EN 61000-3-2	7

O

Offline calculation of position reference vectors to describe the path	26
Old solution with DC drive	6
Operating characteristic	8
Operating characteristic of a standard three-phase AC motor	8

Operation on fault current breaker	31
Optimization of the position controller	62
Outer diameters of wires and cables	101
Output speeds	83
Output voltages	71
Overload pulse	48
Overswill of a liquid	20
Overview of key "A", "B" and "C" norms	49
Overview of motor data, servomotors (LSH)	79
Overview of technical data	79
Overview of types	59

P

P controller characteristic	53
Parallel configuration of two resistors	13
Pendulum of a suspended load	21
Percentage shares of currents due to harmonics ...	4
Permissible encoder, encoder design and motor combination	74
Permissible encoders depending on drive controller	75
Permissible motor cable length with external RFI filter	16
Permissible motor cable length with integral mains filter dependent on standard 61800-3	14
Permissible motor cable length with internal RFI filter	14
Permissible temperature rise limits for insulated windings in continuous duty according to DIN EN 0034-1 / VDE 0530 part 1	77
Pictograms	14
Piston machines, eccentric presses, metal cutters	31
PLC firmware	126
PLC Motion	25
Pole pairs	16
Position of slave drive is non-linear function of position of master drive	28
Positioning accuracy with position control in the drive controller/servocontroller	23
Positioning accuracy with Start/Stop operation ...	106
Positioning drives	
for 230 V systems	146
for 400/460 V systems	147
Positioning errors referred to the motor shaft in °	107
Positioning from A to B	24

Positioning with reference generator and position control in the control	22
Power	7
Power factor, 4-pole standard three-phase AC motor	9
Power rating application example	2
Practical experience with voltage load	44
Practical tip	85
Practical tips	60, 61, 62
Practical working aids for the project engineer ...	109
Probes for testing of touch protection in the IP system	93
Process analysis	5, 8
Programming examples for applications with CDA3000-PLC	126
Project planning	77
Project planning notes	49, 52
Cable length, current and voltage losses	41
Cold plate	12
for DC network operation	64
Project planning notes for drive system with reluctance motors	49
Project planning notes for multi-motor operation	118
Project planning notes for permanent magnet excited motors	52
Project planning notes for three-phase AC motors	102
Projecting planning and installation rules	41
Properties of the three-phase AC motors	85
Protection	91
Equipment for USA and Canada	98
IP code to IEC/EN	91
to EEMAC and Nema	98
Protection categories to EN 50014 ... 50039 (DIN VDE 0170/0171)	80
Protection measures	79
PTC evaluation operation diagram	71
Pulse duration measurement	63

R

Radiated power	
Switch cabinet surface	6
Reactive current compensation system	22
Recommended encoder types	124
Recording of movement task	33

Reduction	
in current harmonics based on CDA3000	144
of system feedback	20
via two gears	24
Reduction factors for internally cooled motors	18
Reduction via one gear	24
Reference position of slave drive is linear function of position of master drive	27
Request Safe Standstill for shutdown in emergency	54
Requirement	
Dust protection	95
Touch protection	94
Water protection	95
Resistance diagram	
of temperature of a DIN PTC	70
of temperature of a PTC KTY 84-130	72
Resistance values	
of a DIN PTC	69
of a linear PTC of type KTY 84-130	72
Resolver	70
Resolver components	70
Resonance frequency in electric power systems	24
Responsibility	15
RFI voltage and RFI field strength (base without absorber), HF irradiation	37
Risk assessment and reduction	50
Risk assessment system	50
RS422 interface	80
Rules for marking of auxiliary terminals	88
S	
Safe Standstill to EN 954-1 category 3	52
Safety engineering for machines with power drives	45
Safety functions	63
Safety functions for movement control	63
Schematic layout and equivalent circuit diagram of the resolver	71
Schematic layout of a drive controller-fed drive in the hazardous zone	76
Schematic of an extruder	5
Schematic view of a crane with suspended load	21
Select motor	3
Selecting the drive controller	34
Selection	
Encoder	58
Gearing	83
Motor	6
Motor brakes	94
Planetary gear	91
Special three-phase AC motors	45
Standard gearing	84
Standard three-phase AC motors	7
Sensor cables	82
Sensorless Flux Control (SFC)	103
Sequence program	129
Sequenced driving set positioning	25
Servocontrollers for 230 V systems	150
Servocontrollers for 400/460 V systems	150
Short-circuit and ground fault proofing	40
Short-circuit voltage	38
Shredder with overload detector	133, 134
SI units	3
Signal level	80
Signal level of the RS422 interface	81
Simplified principle of function of the asynchronous machine	47
Simplified principle of function of the DC machine	45
Simplified principle of function of the permanently excited synchronous machine	46
Simplified view of a single compensation	22
Simplified view of the automatically controlled central compensation system	23
Simplified view of the situation in drive controller operation	23
Simulation of temperature curve	13
Sine/cosine	
Encoder (SinCos)	64
Zero track and inverted signals	65
Sixteen EMC measures to DIN VDE 0100 part 440	43
Solution from functional analysis	7
Solution from process analysis	8
Space required by gearing	86
Special applications	109
Specific drive power for various thermoplasts	11
Speed manipulating range	17
Speed reference filter	61
Stability limit of a conveyed item	19
Standard 3-phase AC motor 1500 rpm , 50 Hz	75
Standard 3-phase AC motor 3000 rpm, 50 Hz	74

Standard 3-phase AC motor, 1000 rpm, 50 Hz	76
Standard drive controller operation	108
Standard screw-type extruder	5
Start/stop positioning	21, 106
Startup characteristic	8
Startup characteristic of a standard three-phase AC motor in mains operation	8
Static speed accuracy	18
Stationary equivalent circuit diagrams of the asynchronous machine	39
Stationary heat conduction through a wall	9
Step response of the speed with optimum overshoot of approx. 20 %	60
Stop category	46
Switching at the drive controller output	38
Switching at the mains input	34
Synchronous motor with cage winding and permanent magnets	50
Synchronous movement	27
Synchronous servomotor	
LSH-074	28
LSH-097	30
LSH-127	32
LSH-50	26
System condition	16
System conditions	19
System conditions for drive controller CDx3000	19
System environment	4
System feedback of power drives	16
Systematic thinking	2

T

Task for a new drive unit	6
Technical data	19, 22, 79
Technical data for installation	100
Technical data of motors	86
Template	33
Test aids used	36
Tested encoders on the CDA3000 inverter module	124
Theoretical service life	68
Thermal adequacy of the motor	5
Thermal classes of electric motors	67
Thermal classes of insulating materials	2, 67
Three-dimensional path generation	26

Three-phase winding	
to new EN60034-8	88
Timed box belt drive	128
Timed processes	127
Tolerances for values of induction machines to VDE 0530	10
Torque	14
Torque as a function of load angle	47, 51
Torque as a function of load angle in the synchronous machine with salient-pole rotor	51
Torque as a function of rotor displacement angle	51
Torque as a function of rotor displacement angle	47
Torque characteristic	46
Synchronous motor with salient-pole rotor	50
Torque characteristic of a reluctance motor in mains operation	46
Torque characteristic of a standard three-phase AC motor	14, 108
Torque characteristic of a synchronous motor with cage winding and permanent magnets	50
Torque formation of motors	45
Torque rise time	16
Torques	12
Torsional rigidity	92
Total harmonic distortion	18
Traction and mechanical function	11
Transmission gear	85
TTL and HTL encoders	60
TTL signals with zero track	61
Two-channel computer structure for the safety function of a movement control	64
Type code	4
Typical accuracies of encoders	76
Typical max. acceleration times of asynchronous servomotors	20

U

UL Component Recognition	27
UL Listing	27

V

V/F characteristic in different load states	41
v/t diagram	12, 88, 29
v/t diagram for minimum torque	30

v/t diagram with sinusoidal characteristic	31
VDE	80
Velocity control	140
Voltage and current conditions in the IT system	18
Voltage conditions in the IT system	17
Voltage dips	19
Voltage Frequency Control (VFC)	103, 39
Voltage load on the motor winding	44

W

Wire uncoiling drive	137, 138
Work	13
Work output for metalworking machinery	8

1

2

3

4

5

6

A

LUST

Lust Antriebstechnik GmbH

Gewerbestr. 5-9 • 35633 Lahnau • Germany
Tel. +49 (0) 64 41 / 9 66-0 • Fax +49 (0) 64 41 / 9 66-137

Heinrich-Hertz-Str. 18 • 59423 Unna • Germany
Tel. +49 (0) 23 03 / 77 9-0 • Fax +49 (0) 23 03 / 77 9-3 97

www.lust-tec.de • info@lust-tec.de
e-mail: info@lust-drivetrionics.de

Id.-Nr.: 0927.25B.1-01 • Stand: 02/2007

Technische Änderungen vorbehalten.