

# Kinco

## PROVEN PERFORMANCE

Customers in over 60 countries and in diverse markets and sectors.



Motion  
Control  
Servo System

## ➔ Servo System Catalog

- CD3/FD3 Series Servo Driver
- Servo Motor



**Kinco® Automation**

www.en.kinco.cn Email:sales@kinco.cn

(All trademarks and logos in this brochure are property of and registered by their respective owners.)

K1E17-1907

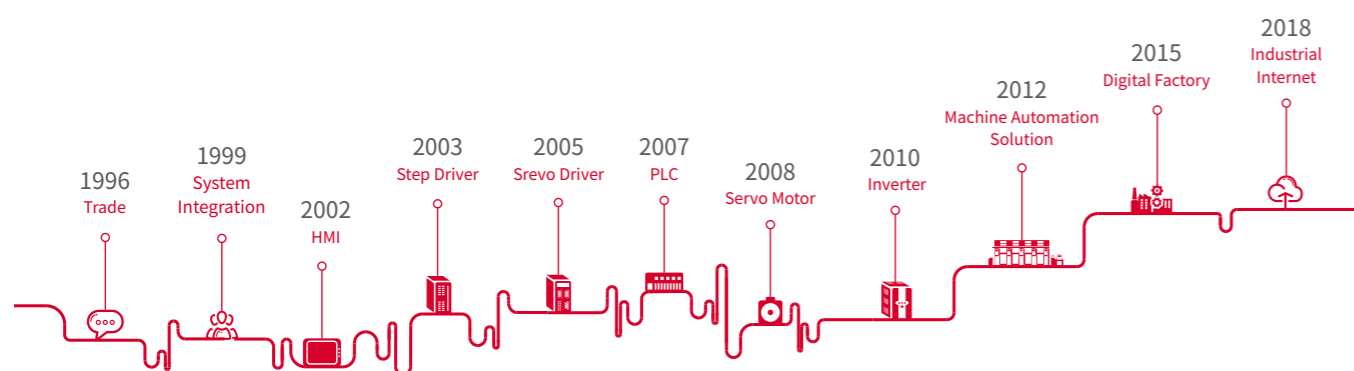

Shanghai Kinco Co., Ltd. specializes in research and development, production, sales and technical services of mobility standard products and intelligent hardware products, and is China's leading supplier of machine mobility and intelligent solutions. In 1996, Bucco relied on the HMI, servo system, stepping system, programmable logic controller PLC, low voltage inverter and other standard automation products to provide the whole world with moving equipment manufacturers. Solution, let China move the banner of the solution to the whole world. The company's mechanical products have led the popularization of HMI in China, and its market share has remained a leading position among the brands for many years. The company's mission is to "make Chinese manufacturing the world's top manufacturing". It insists on the research and development of technology platform for resource precession, and has research and development institutions in Shanghai, Shenzhen and Changzhou. The company already has a comprehensive range of controls, drivers, Mobile technology platforms for machine interaction, communication and mechatronic design. In the field of machine movement, Kinco focuses on the industry and has developed machines suitable for logistics movement, service machines, medical instruments, professional machines and 3C machines. Special solutions for bed, ozone and other industries.

In the field of Smart factory, Kinco aims at the on-site management layer, PLC control and communication layer, Scada and system integration layer of manufacturing enterprises through the perfect dynamic technology platform and software system developed for intelligence. MES management provides the easiest intelligent solution for customers.

Kinco takes "wisdom makes good life" as its vision and adheres to the values of "conscience makes success, craftsman makes innovation". Kinco is a platform for helping employees to develop their creative potential as much as possible and a partner to help customers achieve success in their innovative operation. We develop our products and business with innovative thinking and real spirit, adhere to our ideals, and hope that the creation of the class will make the world more beautiful.

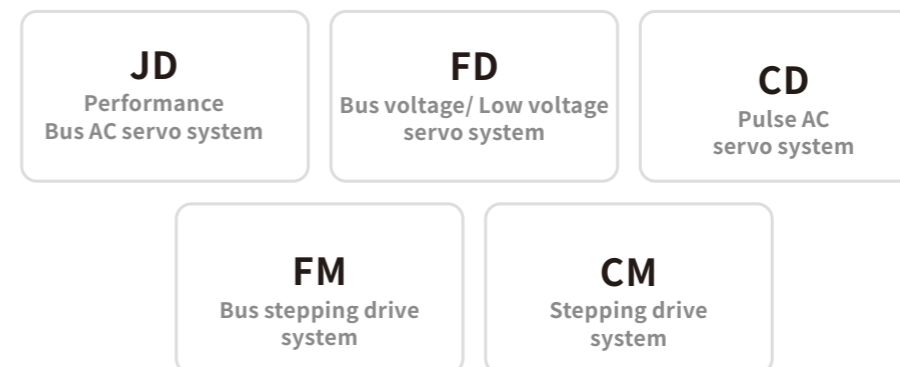

- Precision motor control technology originated from germany, with pulse holding, Modbus/CANopen/EtherCAT bus and other control types.
- Can drive all kinds of servo motors and stepper motors, including rotary servo motors, linear motors, direct driver, etc.
- It should be widely used in logistics AGV, 3C, medical, new energy and machinery industries.
- The product conforms to international quality and design standards and is the ODM first choice for International brand servo.

## 03 SUMMARIZE

- Driver characteristics
- Naming Rules for Drives and Motors/Cables
- Driver and Motor Configuration Table
- Driver/Motor Model Table

## 09 DRIVER INTRODUCTION

- Parameter table
- Description of external wiring and communication terminals
- Mechanical dimension

## 16 MOTOR INTRODUCTION

- Motor characteristics
- Parameter table
- Torque-velocity curve
- Mechanical dimension

## 27 MOTOR CABLE CONNECTION TABLE

- Encoder cable
- Motor power cable
- Brake cable

## 30 APPENDIX:

- Drives and Motor/Cable Selection Table



# Always, good quality power expansion 3000W

CD3/FD3AC servo family  
Add new members!



## CD3/FD3 Product features

CD3/FD3 series AC servo system is an economical servo product launched by Bucco to the general servo market, with a power range of 50W~3kW. It can be widely used in logistics, 3C electricity, printing and packaging, textile machinery, machinery, lithium batteries, new energy and other industries.

### Compact structure, power density



### Holding Multiple Encoder Protocols



### Dynamic braking

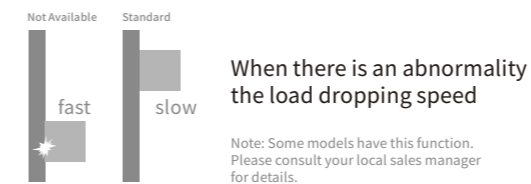

### Hold fully closed loop



### Easy Tune Gain automatic adjustment

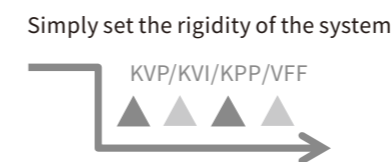

### Multi-bus communication



### 32-segment position table



### M-IoT



- Perfect adaptation of Kinco M-IoT robot linkage solution.
- Easy access to the cloud enables real-time monitoring and pre-maintenance of equipment.
- Add the function of clearing pulse, it will track down the clamp.
- Support Motor model and parameter identification of the motor.
- Support 4MHz pulse transmission
- Support encoder frequency division output power
- Supply with 220v logic power
- Supply 5V Output

# Naming Rules for Drivers and Motors/Cables

Driver: **FD423-EA-000**

① ② ③ ④ ⑤ ⑥



①-Name CD: CD Series FD: FD Series	④-Driver version 3: 3rd generation driver
②-Main supply power 4: input AC220V 6: input AC380V	⑤-Controlled type EA: RS232, EtherCAT CA: RS232, CAN LA: RS232, RS485 AA: Standard for CD Series Drives Only
③-Current 1: AC220V 2A 2: AC220V 3.9A or AC380V 7A 3: AC220V 10A	⑥-Software version 000: Software version number

Motor: **SMC60S-0020-30MAK-3LSU**

① ② ③ ④ ⑤ ⑥ ⑦ ⑧ ⑨ ⑩ ⑪ ⑫



①-Name SMC: SMC Series SMS: SMS series	⑦-Brake A: Without brake B: With brake
②-flang size 40: 40x40(mm) 60: 60x60(mm) 80: 80x80(mm) 130: 130x130(mm)	⑧-Motor outlet type A: Axis without keyway K: With keys
③-Inertia type S: Small inertia D: Medium inertia	⑨-Number of pole-pairs 3: 3 pole pair 4: 4 pole pair 5: 5 pole pair
④-Rated power: 0005: 5x10(W) 0010: 10x10(W) 0020: 20x10(W) 0040: 10x40(W) .....	⑩- Main supply power: L: AC220V H: AC380V
⑤-Rated speed: 20: 20x100(rpm) 30: 30x100(rpm)	⑪-Motor version number S: S Version K: K Version
⑥-Encoder type M: 16 bit single-turn magnetoelectric encoder K: Multi-turn absolute encoder	⑫- Motor outlet type U: Communication encoder socket P: HFO21+HFO18 series general aviation socket Remarks: Manually insert HFO21 and encoder insert HFO18

# Naming Rules for Drivers and Motors/Cables

Power cable: **MOTF-005-LL-KL-Y**

① ② ③ ④ ⑤ ⑥



①-Cable function type MOT: Motor power cable	④-Cable length 03:3m/05:5m/ 10:10m 15:15m/20:20m
②-Cable type F: Cable train cable Empty: Standard cable	⑤-Motor outlet type KL: 4PIN power connector KC4: HFO21 Series General Aviation
③-Rated current 005: 5A 008: 8A	⑥-Joint type Y: PE end connector is Y-shaped B: The moving wire includes brake cable (suitable for KC4 aviation socket brake motor)

Encoder cable: **ENC DGF-LL-GU-BT**

① ② ③ ④ ⑤ ⑥ ⑦ ⑧



①-Cable function type ENC: Motor encoder line	⑤-Cable length 03:3m/05:5m/ 10:10m 15:15m/20:20m
②-Driver encoder port type D: 1394 connection	⑥-Core wire type G: 6-core cable
③ Driver connection definition G: Communication connection	⑦-Type of encoder connector at motor end U: 1394 connector C0: HFO series general aviation plug
④-Cable type F: Flexible cable Empty: Standard cable	⑧ Cable accessories BT: With battery (suitable for multi-turn absolute encoder motor) Empty: Without battery

















Brake cable: **BRAF-LL-KL**

① ② ③ ④



①-Cable function type BRA: Motor brake line	③-Cable length 03:3m/05:5m/ 10:10m 15:15m/20:20m
②-Cable type F: Flexible cable Empty: Standard cable	④-Connector type KL: 2PIN Brake plug

# Driver and Motor Configuration

	AC220V	50W		SMC40S-0005-30M□K-5LSU SMS40S-0005-30K□K-5LSU
		100W		SMC40S-0010-30M□K-5LSU SMS40S-0010-30K□K-5LSU
				SMC60S-0020-30M□K-3LSU SMS60S-0020-30K□K-3LSU
	AC220V	400W		SMC60S-0040-30M□K-3LSU SMS60S-0040-30K□K-3LSU
				SMC80S-0075-30M□K-3LSU SMS80S-0075-30K□K-3LSU
		750W		SMC130D-0100-20G□K-4LSP SMS130D-0100-20K□K-4LKP
	AC220V	1kW		SMC130D-0150-20G□K-4LSP SMS130D-0150-20K□K-4LKP
		1.5kW		SMC130D-0200-20G□K-4LSP SMS130D-0200-20K□K-4LKP
		2kW		SMC130D-0300-20G□K-4HSP SMS130D-0300-20K□K-4HKP
	AC380V	1kW		SMC130D-0100-20G□K-4HSP
		1.5kW		SMC130D-0150-20G□K-4HSP SMS130D-0150-20K□K-4HKP
				SMC130D-0200-20G□K-4HSP SMS130D-0200-20K□K-4HKP
		2kW		SMC130D-0300-20G□K-4HSP SMS130D-0300-20K□K-4HKP
		3kW		SMC130D-0300-20G□K-4HSP SMS130D-0300-20K□K-4HKP

Note 1: ★ FD 433-EA-000 and FD623-EA-000 are expected to be listed in the fourth quarter of 2019.

Note 2: □ = A : Motor without brake  
□ = B : Motor with brake

# Driver Model List

Series	Model	Power (W)	Main supply voltage	MAX continuous output current (Arms) (A)	Peak current (A)	Control model	Weight (Kg)	Mechanical dimensions (mm)		
CD Series	CD413-AA-000	50/100/200	AC220V	2	7	Pulse	0.8	160×138×41		
	CD423-AA-000	400/750		3.9	15					
	CD433-AA-000	1000/1500/2000	AC380V	10	27.5		1.33	194×185×56		
	CD623-AA-000	1000/1500/2000/3000		7	25					
FD Series	FD413-LA-000	50/100/200	AC220V	2	7	RS485	0.8	160×138×41		
	FD413-CA-000					CANopen				
	FD413-EA-000					EtherCAT				
	FD423-LA-000	400/750		3.9	15	RS485				
	FD423-CA-000					CANopen				
	FD423-EA-000	EtherCAT								
	FD433-LA-000	1000/1500/2000		10	27.5	RS485			1.33	194×185×56
	FD433-CA-000					CANopen				
	FD433-EA-000					EtherCAT				
	FD623-LA-000	1000/1500/2000/3000		7	25	RS485				
FD623-CA-000	CANopen									
FD623-EA-000	EtherCAT									

# Motor Model List

Flange size	Model	Rated power Pn(W)	Rated torque Tn(Nm)	Rated speed nN(rpm)	Rated current In(A)	Diameter of axle (mm)	Length of motor (mm)	
							□ = A	□ = B (with brake)
40mm	SMC40S-0005-30M□K-5LSU SMS40S-0005-30K□K-5LSU	50	0.16	3000	0.7	8	74.6±1.5	104.6±1.5
	SMC40S-0010-30M□K-5LSU SMS40S-0010-30K□K-5LSU	100	0.32		1.4		96.6±1.5	126.6±1.5
	SMC60S-0020-30M□K-3LSU SMS60S-0020-30K□K-3LSU	200	0.64		1.4		91±1.5	121±1.5
60mm	SMC60S-0040-30M□K-3LSU SMS60S-0040-30K□K-3LSU	400	1.27	3000	2.4	14	117±1.5	147±1.5
	SMC80S-0075-30M□K-3LSU SMS80S-0075-30K□K-3LSU	750	2.39		3.8		128.5±1.5	158±1.5
80mm	SMC130D-0100-20G□K-4LSP SMS130D-0100-20K□K-4LKP	1000	4.8	2000	4.4	22	143±1.5	204±1.5
	SMC130D-0100-20G□K-4HSP				2.27			
	SMC130D-0150-20G□K-4LSP SMS130D-0150-20K□K-4LKP	1500	7.2		6.8		159±1.5	220±1.5
	SMC130D-0150-20G□K-4HSP SMS130D-0150-20K□K-4HKP				4.5			
	SMC130D-0200-20G□K-4LSP SMS130D-0200-20K□K-4LKP	2000	9.6		8.8		179±1.5	240±1.5
	SMC130D-0200-20G□K-4HSP SMS130D-0200-20K□K-4HKP				6.2			
	SMC130D-0300-20G□K-4HSP SMS130D-0300-20K□K-4HKP				6.7			
	SMC130D-0300-20G□K-4HSP SMS130D-0300-20K□K-4HKP	3000	14.3		6.7		219±1.5	280±1.5

# CD3/FD3 Parameter Table



Model Parameter		CD3-Pulse servo driver			
		CD413-AA-000	CD423-AA-000	CD433-AA-000	CD623-AA-000
Power	Main supply voltage	1PH, 200-240VAC ±10% 50/60Hz ±3Hz, (750W 7A), (200W 3A)		1PH, 3PH, 200-240VAC 50/60Hz 14.0A	3PH, 380-415VAC 50/60Hz 12.0A
	Control power	200-240VAC ±10%, 50/60Hz ±3Hz, 0.5A			
Rated output current	Rated current (rms)	2A	3.9A	10A	7A
	Peak current (PEAK)	7A	15A	27.5A	25A
Feedback signal		16 bit Single-turn magnetoelectric encoder, multi-turn absolute encoder			
Brake chopper		Built-in braking resistor 100 Ω, limiting power 10 W; If the actual power exceeds 10W, an external braking resistor is required. (mainly in quick start and stop application)			
Brake chopper threshold		DC380V ±5V	DC380V ±5V	DC380V ±5V	DC680V ±5V
Over-voltage alarming threshold		DC400V ±5V	DC400V ±5V	DC400V ±5V	DC700V ±5V
Under-voltage alarming threshold		DC200V ±5V	DC200V ±5V	DC200V ±5V	DC400V ±5V
Cooling method		Natural air cooling	With fan	With fan	With fan
Weight (KG)		0.8		1.33	
Position control mode	Maximum input pulse frequency	Differential transmission mode: up to 4MHz, open collector transmission mode: 500KHz			
	Pulse command mode	Pulse+direction, CCW+CW, phase A+ phase B (5V~24V)			
	Instruction smoothing mode	Low-pass filtering (internal parameter setting)			
	Feedforward gain	Internal parameter setting			
	Electronic gear ratio	Setting range Gear factor: -32768~32767, Gear divider: 1~32767, 1/50 ≤  Gear factor/Gear divider  ≤ 50			
Position loop sampling frequency		1KHz			
Speed control mode	Analog input voltage range	-10~+10V (Resolution 12 bits)			
	Input impedance	200K			
	Analog input sampling frequency	4KHz			
	Command control mode	External analog command / internal command			
	Instruction smoothing mode	Low-pass filtering (internal parameter setting)			
	Input voltage dead zone setting	Internal parameter setting			
	Input voltage offset setting	Internal parameter setting			
	Speed limit	Internal parameter setting			
	Torque limit	Internal parameter setting/External analog command control			
	Speed loop sampling frequency	4KHz			
Torque control mode	Analog voltage input range	-10~+10V (Resolution 12 bits)			
	Input impedance	200K			
	Input sampling frequency	4KHz			
	Command control mode	External analog command / internal command			
	Instruction smoothing mode	Low-pass filtering (Internal parameter setting)			
	Speed limit	Internal parameter setting/External analog command control			
	Input voltage dead zone setting	Internal parameter setting			
Digital input	Input specification	7 digital inputs, with COM1 terminal for PNP (high level valid 12.5~30V) or NPN (low level valid 0~5V) connection			
	Input function	Define freely according to requirement, supporting following functions: Driver enable, driver fault reset, driver mode control, speed loop proportional control, positive limit, negative limit, homing signal, reverse command, internal speed section control, internal positive section control, quick stop, start homing, active command, switch electronic gear ratio, switch gain, Position table function, clear pulse function			
	Output specification	5 digital output, maximum voltage DC30V, differential output of OUT1 and OUT2, maximum output current of 100mA, single-ended output of OUT 3 ~ OUT 5, maximum output current of 20mA, and motor OUT2 brake output controlled by relay.			
	Output function	Define freely according to requirement, supporting following functions: Driver ready, driver fault, position reached, motor zero speed, motor brake, motor speed reached, Z signal, maximum speed obtained in torque mode, motor lock, position limiting, reference found. Multistage position.			
Protection function		Over-voltage protection, under-voltage protection, motor over-heat protection(I2T), short-circuit protection, driver over-heat protection, etc.			
RS232		RS232(Connection with PC: RJ45 network port)			
Operation environment	Operation temperature	0~40°C			
	Storage temperature	-10°C~70°C			
	Humidity(non-condensing)	Below 90%RH			
	Protection class	IP20			
	Installation environment	Installed in a dust-free, dry and lockable environment (such as in an electrical cabinet)			
	Installation mode	Vertical installation			
	Height	Rated working altitude at 1000m or below, Above 1000m: Decreasing 1.5% per 100m rise, maximum altitude 4000m			
Atmospheric pressure		86kpa~106kpa			

# CD3/FD3 Parameter Table



Model Parameter		FD3-Bus servo driver			
		FD413-□A-000	FD423-□A-000	FD433-□A-000	FD623-□A-000
Power	Main supply voltage	1PH, 200-240VAC ±10% 50/60Hz ±3Hz, (750W 7A), (200W 3A)		1PH, 3PH, 200-240VAC 50/60Hz 14.0A	3PH, 380-415VAC 50/60Hz 12.0A
	Control power	200-240VAC ±10%, 50/60Hz ±3Hz, 0.5A			
Rated output current	Rated current (rms)	2A	3.9A	10A	7A
	Peak current (PEAK)	7A	15A	27.5A	25A
Feedback signal		16 bit Single-turn magnetoelectric encoder, multi-turn absolute encoder			
Brake chopper		Built-in braking resistor 100 Ω, limiting power 10 W; If the actual power exceeds 10W, an external braking resistor is required. (mainly in quick start and stop application)			
Brake chopper threshold		DC380V ±5V	DC380V ±5V	DC380V ±5V	DC680V ±5V
Over-voltage alarming threshold		DC400V ±5V	DC400V ±5V	DC400V ±5V	DC700V ±5V
Under-voltage alarming threshold		DC200V ±5V	DC200V ±5V	DC200V ±5V	DC400V ±5V
Cooling method		Natural air cooling	With fan	With fan	With fan
Weight (KG)		0.8		1.33	
Position control mode	Maximum input pulse frequency	Differential transmission mode: up to 4MHz, open collector transmission mode: 500KHz			
	Pulse command mode	Pulse+direction, CCW+CW, phase A+ phase B (5V~24V)			
	Instruction smoothing mode	Low-pass filtering (internal parameter setting)			
	Feedforward gain	Internal parameter setting			
	Electronic gear ratio	Setting range Gear factor: -32768~32767, Gear divider: 1~32767, 1/50 ≤  Gear factor/Gear divider  ≤ 50			
Position loop sampling frequency		1KHz			
Speed control mode	Analog input voltage range	-10~+10V (Resolution 12 bits)			
	Input impedance	200K			
	Analog input sampling frequency	4KHz			
	Command control mode	External analog command / internal command			
	Instruction smoothing mode	Low-pass filtering (internal parameter setting)			
	Input voltage dead zone setting	Internal parameter setting			
	Input voltage offset setting	Internal parameter setting			
	Speed limit	Internal parameter setting			
	Torque limit	Internal parameter setting/External analog command control			
	Speed loop sampling frequency	4KHz			
Torque control mode	Analog voltage input range	-10~+10V (Resolution 12 bits)			
	Input impedance	200K			
	Input sampling frequency	4KHz			
	Command control mode	External analog command / internal command			
	Instruction smoothing mode	Low-pass filtering (Internal parameter setting)			
	Speed limit	Internal parameter setting/External analog command control			
	Input voltage dead zone setting	Internal parameter setting			
Digital input	Input specification	7 digital inputs, with COM1 terminal for PNP (high level valid 12.5~30V) or NPN (low level valid 0~5V) connection			
	Input function	Define freely according to requirement, supporting following functions: Driver enable, driver fault reset, driver mode control, speed loop proportional control, positive limit, negative limit, homing signal, reverse command, internal speed section control, internal positive section control, quick stop, start homing, active command, switch electronic gear ratio, switch gain, Position table function, clear pulse function			
	Output specification	5 digital output, maximum voltage DC30V, differential output of OUT1 and OUT2, maximum output current of 100mA, single-ended output of OUT 3 ~ OUT 5, maximum output current of 20mA, and motor OUT2 brake output controlled by relay			
	Output function	Define freely according to requirement, supporting following functions: Driver ready, driver fault, position reached, motor zero speed, motor brake, motor speed reached, Z signal, maximum speed obtained in torque mode, motor lock, position limiting, reference found. Multistage position			
Encoder signal output function		Output 5V motor A, B and Z signals, frequency division output range 0 ~ 65536; For multi-axis synchronization, maximum output frequency 2MHz			
Protection function		Over-voltage protection, under-voltage protection, motor over-heat protection(I2T), short-circuit protection, drive over-heat protection, etc.			
RS232		The maximum baudrate is 115.2KHz, use JD-PC software to communicate with PC, or via free protocol to communicate with controller			
RS485		The maximum baudrate is 115.2KHz, use Modbus RTU protocol to communicate with controller			
CAN BUS		The maximum baudrate is 1MHz, use CANopen protocol to communicate with controller			
EtherCAT		The maximum baudrate is 100MHz, support COE (CIA 402 protocol) and CSP / CSV / PP / PV / PT / HM mode			
Operation environment	Operation temperature	0~40°C			
	Storage temperature	-10°C~70°C			
	Humidity(non-condensing)	Below 90%RH			
	Protection class	IP20			
	Installation environment	Installed in a dust-free, dry and lockable environment (such as in an electrical cabinet)			
	Installation mode	Vertical installation			
	Height	Rated working altitude at 1000m or below, Above 1000m: Decreasing 1.5% per 100m rise, maximum altitude 4000m			
Atmospheric pressure		86kpa~106kpa			

Note: □=L: RS232, RS485 □=C: RS232, CANopen □=E: RS232, EtherCAT



# External wiring diagram of driver

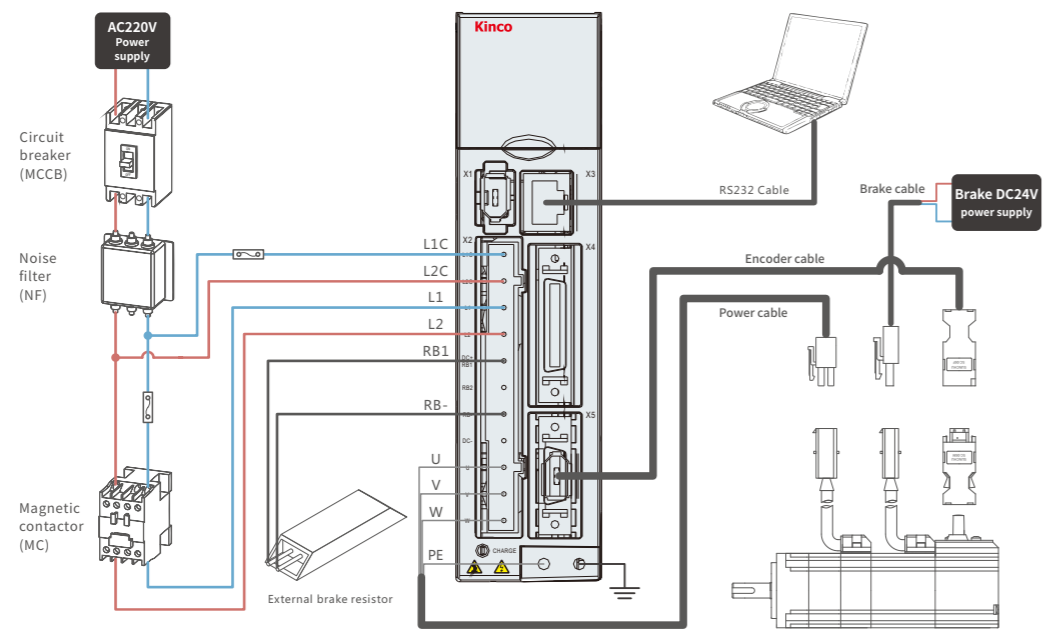

CD413/CD423/FD413/FD423 (AC220V)

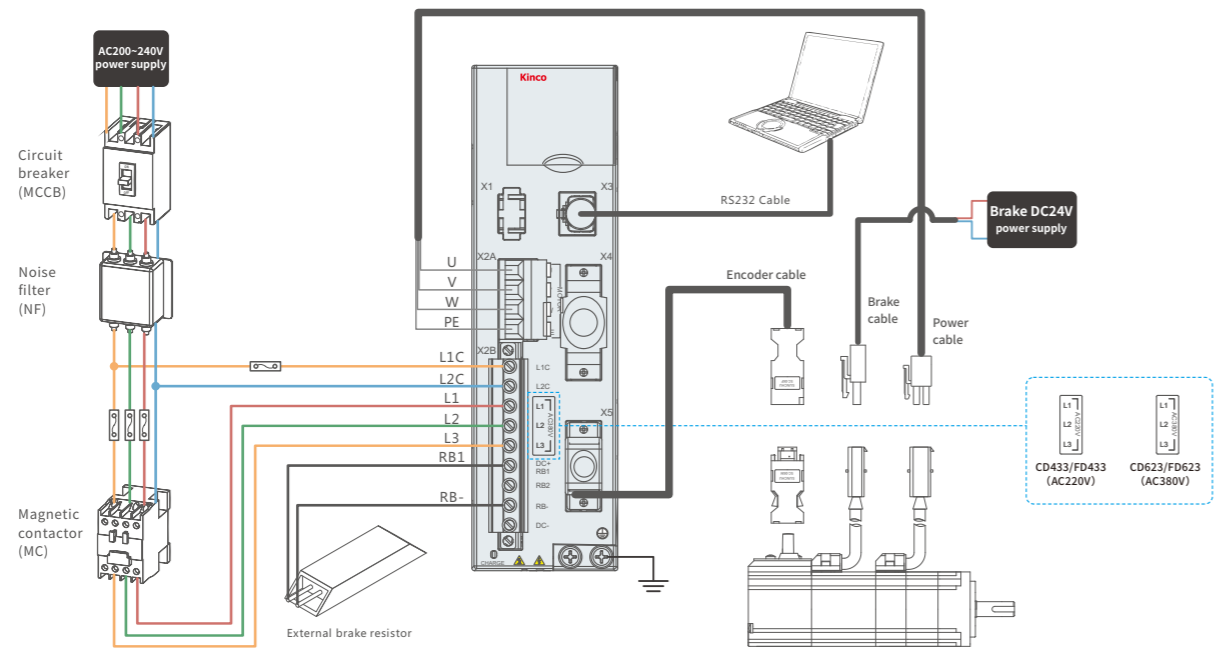

CD433/CD623/FD433/FD623 (AC220V/AC380V)

Note: When enabling the internal braking resistor, please short circuit DC+/RB1 to RB2 (internal braking resistor resistance: CD&FD 413/423 with built-in 100Ω/10W; CD&FD433 has built-in 100Ω/20W; CD&FD623 has 300Ω/20W internal), exceeding the power driver. An over-power alarm of brake resistance will be reported and "0100" will be displayed.  
 When the actual braking power demand exceeds the limit power, please select to connect the external braking resistor between DC+/RB1 and RB-, and at the same time make sure to switch off. Short wiring of DC+/RB1 and RB2. Please refer to the user manual for selection of external braking resistance.

# Driver Communication interface Description

Available to CD&FD413/423 driver

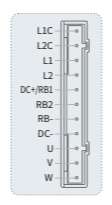

Port No.	Port name	Port type	Pin No.	Single marks	Single name	Specifications
X2	Power terminal	11P 7.5mm Plugging terminal	1	L1C	Control power input	200~240VAC±10% 50/60Hz±3Hz 0.5A
			2	L2C		
			3	L1	Main power supply input	200~240VAC±10% 50/60Hz±3Hz (750W 7A, 200W 3A)
			4	L2		
			5	DC+/RB1	DC bus Brake resistor connection	DC+/RB1, DC- Positive and negative ends of DC bus★
			6	RB2		
			7	RB-	Motor cable connection	Connect motor cable U, V, W
			8	DC-		
			9	U		
			10	V		
			11	W		

Available to CD&FD433/623 driver

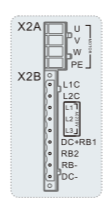

Port No.	Port name	Port type	Pin No.	Single marks	Single name	Specifications
X2A		DINKLE ECH762R-S1156604P-GY (Gray)	1	U	Motor cable port	Connect motor cable U, V, W, PE
			2	V		
			3	W		
			4	PE		
X2B	Power terminal	DINKLE 3EHDRM-09P-GY	1	L1C	Control power input	200~240VAC±10%, 50/60Hz±3Hz, 0.5A
			2	L2C		
			3	L1	Main power supply input	1PH, 3PH, 200-240VAC 50/60Hz (CD&FD433 14A, CD&FD623 12A)
			4	L2		
			5	L3	DC bus Brake resistor connection	DC+/RB1, DC- Positive and negative ends of DC bus★
			6	DC+/RB1		
			7	RB-		
			8	DC-		

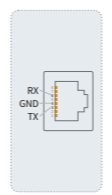

Port No.	Port name	Port type	Pin No.	Single marks	Single name	Specifications
X3	RS232 Communication interface	RJ45 Netport female	1	NC	Can be connected to PC-side PC software for parameter setting, monitoring status, etc.	
			2	NC		
			3	TX		Send data
			4	GND		Ground
			5	NC		
			6	RX		Receive data
			7	NC		
			8	NC		

Note: ★ With external brake resistance, short connect DC+/RB1 and RB- and disconnect DC+/RB1 and RB2 at the same time.

## Driver Communication interface Description



Port No.	Port name	Port type	Pin No.	Single marks	Single name	Specifications
X4	I/O interface	SCSI-36P-F	1	OUT1+	Differential output	Open collector output, maximum voltage DC30V, maximum current 100mA
			3	OUT1-		
			5	OUT2+		
			7	OUT2-		
			9	OUT3		
			11	OUT4	Single-ended output	Maximum voltage DC30V, maximum current 20mA
			20	OUT5		
			13	COMO		
			15	VDD	Internal 24V Power Output	Internal 24V power output, voltage range +/-20%, maximum current 300mA
			17	VEE		
			2	COMI	Input signal common terminal	Digital transmission common terminal can be connected to power supply range DC18~30V
			4	DIN1	Digital signal input terminal	High level: 12.5V-30V Low level: 0-5V Maximum input frequency: 1KHz
			6	DIN2		
			8	DIN3		
			10	DIN4		
			12	DIN5		
			14	DIN6		
			16	DIN7		
			19	AIN1+ (/MA)	Analog input1, ±10V	MA, MB, MZ, ma/mb/mz/RS422 differential with 5V Signal input, maximum pulse frequency 4MHz, optional in signal type: ① Pulse+Direction (PLS+DIR) ② Forward and reverse pulse (CW/CCW) ③ A+B phase
			21	AIN1- (/MB)		
			23	AIN2+ (/MZ)	Analog input2, ±10V	MA, MB, MZ, ma/mb/mz/RS422 differential with 5V Signal input, maximum pulse frequency 4MHz, optional in signal type: ① Pulse+Direction (PLS+DIR) ② Forward and reverse pulse (CW/CCW) ③ A+B phase
			25	AIN2-		
			27	MA+/(MA)	TTL Signal: MA+,MA-MB+,MB-,MZ+,MZ-, Support maximum frequency: 500KHz, Voltage range DC 3.3-30V Differential signal: MA,/MA,MB,/MB,MZ,/MZ, Support maximum frequency 4MHz, Voltage range DC 3.3-5V	Pulse signal input terminal holds TTL/differential signal. Signal types are optional: ① Pulse+Direction (PLS+DIR) ② Forward and reverse pulse (CW/CCW) ③ A+B phase
			29	MA-		
			31	MB+/(MB)		
			33	MB-		
			35	MZ+/(MZ)		
			18	MZ-	Internal 5V Power Output	Output 5V motor A, B, Z signals, Divided frequency output range 0~65536; In multi-axis synchronization, Maximum output frequency 5MHz
			22	+5V		
			24	GND	Encoder signal output	
			26	ENCO_Z		
			28	ENCO_Z		
			30	ENCO_B		
			32	ENCO_B		
			34	ENCO_A		
			36	ENCO_A		

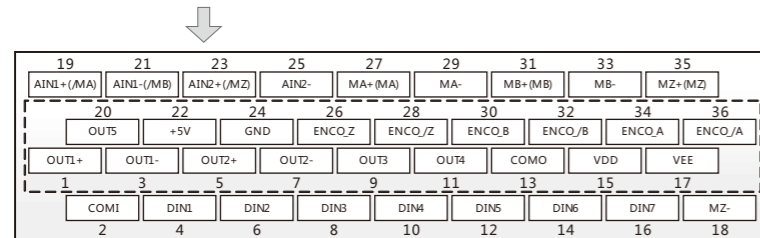
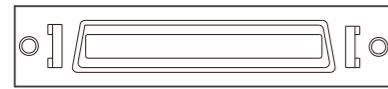

## Driver Communication interface Description

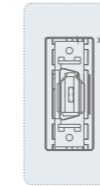

Port No.	Port name	Port type	Pin No.	Single marks	Single name	Specifications
X5	Motor Encoder interface	1394 female	1	+5V	5V power output +	Encoder signal input terminal
			2	GND	5V power output-	
			3	CLOCK+	Clock signal +	
			4	CLOCK-	Clock signal-	
			5	SD	Data signal	
			6	/SD	Data signal	

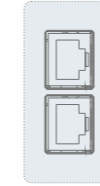

Port No.	Port name	Port type	Pin No.	Single marks	Single name	Port No.	Port name	Port type	Pin No.	Single marks	Single name
X6A	RS485 Communication interface input	RJ45 Netport female	1	RX+	Receive data+	X6B	RS485 Communication interface output	RJ45 Netport female	1	RX+	Receive data+
			2	RX-	Receive data-				2	RX-	Receive data-
			3	NC					3	NC	
			4	TX-	Send data-				4	TX-	Send data-
			5	TX+	Send data+				5	TX+	Send data+
			6	NC					6	NC	
			7	+5VB	Isolated+5V Output <sup>*1</sup>				7	+5VB	Isolated+5V Output <sup>*1</sup>
			8	GNDB	ground				8	GNDB	ground

\*1 Specification: built-in 100 Ω resistance, used as a pull-up resistor or pulldown resistor, cannot be used as the output power.

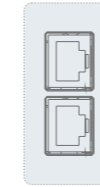

Port No.	Port name	Port type	Pin No.	Single marks	Single name	Port No.	Port name	Port type	Pin No.	Single marks	Single name
X6A	CAN Communication interface input	RJ45 Netport female	1	CAN_H	Singal+	X6B	CAN Communication interface output	RJ45 Netport female	1	CAN_H	Singal+
			2	CAN_L	Singal-				2	CAN_L	Singal-
			3	GNDB	Ground				3	GNDB	Ground
			4	NC					4	NC	
			5	NC					5	NC	
			6	NC					6	NC	
			7	NC					7	NC	
			8	NC					8	NC	

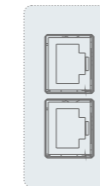

Port No.	Port name	Port type	Pin No.	Single marks	Single name	Port No.	Port name	Port type	Pin No.	Single marks	Single name
X6A	EtherCAT Communication interface input	RJ45 Netport female	1	TD+	Receive singal+	X6B	EtherCAT Communication interface output	RJ45 Netport female	1	TD+	Receive singal+
			2	TD-	Receive singal-				2	TD-	Receive singal-
			3	RD+	Send singal+				3	RD+	Send singal+
			4	NC					4	NC	
			5	NC					5	NC	
			6	RD-	Send singal-				6	RD-	Send singal-
			7	NC					7	NC	
			8	NC					8	NC	

Port No.	Port name	Specifications
SW1	8 dip switch	Communication ID dip switch
SW2	On CANopen-only drives are	Terminal resistance switch



# Driver Dimensions

Unit:mm

## CD&FD413/CD&FD423 dimensions

Note: wiring space should be reserved around the driver, >60mm is better; CD413-AA-000, FD413-□A-000 without fan.

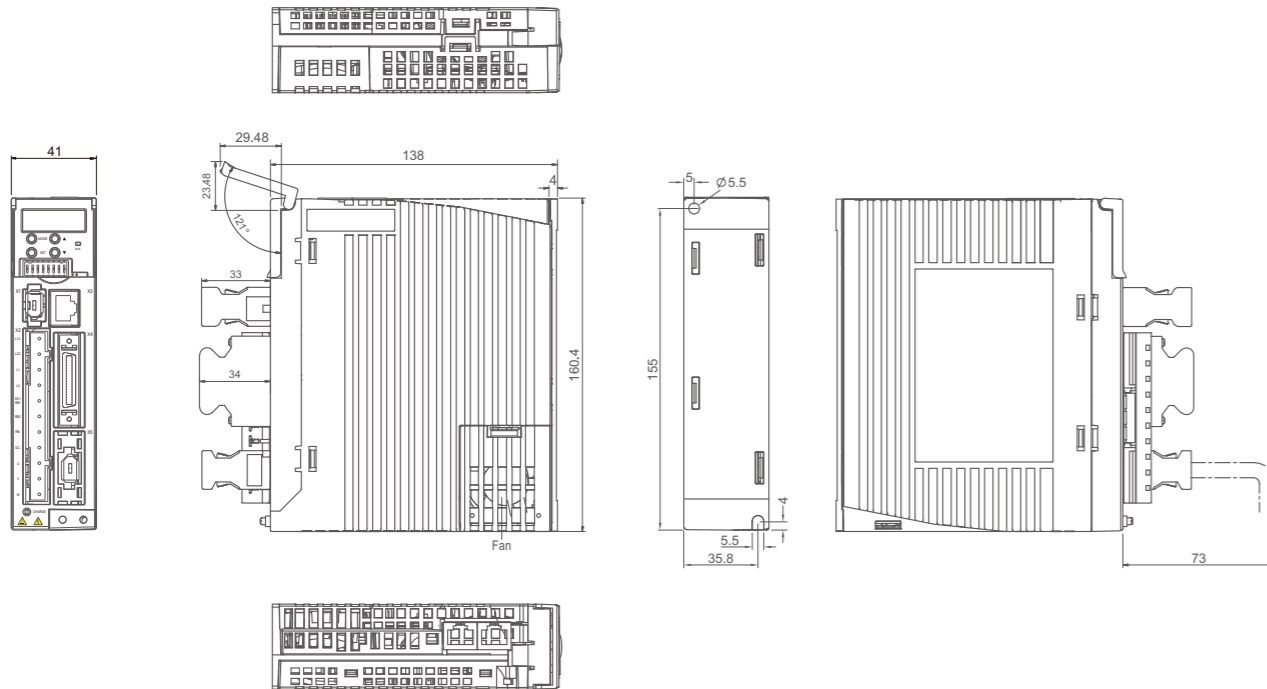

## CD&FD433/CD&FD623 dimensions

Note: wiring space should be reserved around the driver, >60mm is better.

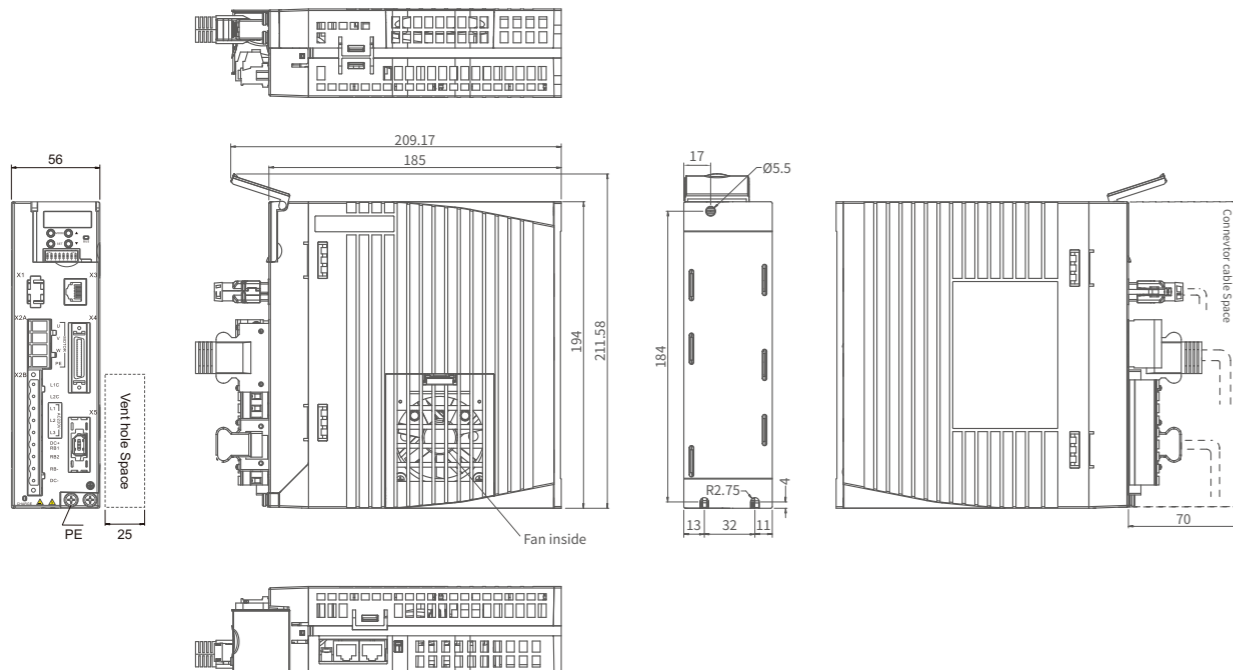

The new 16-bit high performance magnetolectric encoder  
Good shock resistance and high cost performance

The motor body is further shrunk  
The insulation grade of the motor is F

## RELIABLE & STABLE



# Technical Specifications of Servo Motor



Model parameter		Small inertia, flange size of 40mm	
Servo motor		SMC40S-0005-30M□K-5LSU SMS40S-0005-30K□K-5LSU	SMC40S-0010-30M□K-5LSU SMS40S-0010-30K□K-5LSU
Available driver		CD413-AA-000 FD413-LA-000 FD413-CA-000 FD413-EA-000	
DC link voltage VDC		300	300
Continuous performance	Rated power Pn (W)	50	100
	Rated torque Tn (N.m)	0.16	0.32
	Rated speed nN (rpm)	3000	3000
	Rated current In (A)	0.7	1.4
	Maximum torque Tm (N.m)	0.48	0.96
Maximum current Im (A)	2.25	4.2	
Standstill torque Ts (N.m)	0.176	0.352	
Standstill current Is (A)	0.83	1.54	
Resistance Line - Line RL (Ω)	16.2	7.9	
Inductance Line - Line LL (mH)	18.5	10.5	
Electrical time constant τe (ms)	1.14	1.33	
Mechanical time constant τm (ms)		1.51	0.99
		1.51 (with brake)	0.99 (with brake)
Reverse voltage constant Ke (V/krpm)	14	16.2	
Torque constant kt (N.m/A)	0.232	0.268	
Rotor moment of inertia Jm (Kg·cm <sup>2</sup> )		0.018	0.033
		0.021 (with brake)	0.046 (with brake)
Brake holding torque T (Nm)	0.32	0.32	
Pole pair number	5	5	
Maximum voltage rising du/dt (kv/μs)	8	8	
Insulation class	F	F	
Maximum radial force Fr (N)	120	120	
Maximum axial force Fa (N)	60	60	
Weight G (Kg)		0.4	0.57
		0.6 (with brake)	0.77 (with brake)
Length of motor L (mm)		74.6±1	96.6±1
		104.6±1.5 (with brake)	126.6±1 (with brake)
Position feedback device	SMC series-16 bit single-turn magnetoelectric encoder; SMS series-Multi-turn absolute encoder		
Cooling method	Totally enclosed, non - ventilated		
Protection level	IP65, shaft sealing IP54 (Note: Add oil seal IP54 at the shaft end and do not add oil seal IP50)		
Environment conditions for operation	Temperature	-20~40°C (non-freezing)	
	Humidity	Below 90% RH (no condensation)	
	Ambient environment	Away from active gas, combustible gas, oil drops and dust	
	Altitude	Maximum altitude 4000m, rated power at 1000m or below. Above 1000m, decreasing 1.5% per every 100m rise	

Note: □ = A : Motor without brake  
 □ = B : Motor with brake

# Technical Specifications of Servo Motor



Model parameter		Small inertia, flange size of 60mm		Small inertia, flange size of 80mm	
Servo motor		SMC60S-0020-30M□K-3LSU SMS60S-0020-30K□K-3LSU	SMC60S-0040-30M□K-3LSU SMS60S-0040-30K□K-3LSU	SMC80S-0075-30M□K-3LSU SMS80S-0075-30K□K-3LSU	
Available driver		CD413-AA-000 FD413-LA-000 FD413-CA-000 FD413-EA-000		CD423-AA-000 FD423-LA-000 FD423-CA-000 FD423-EA-000	
DC link voltage VDC		300	300	300	
Continuous performance	Rated power Pn (W)	200	400	750	
	Rated torque Tn (N.m)	0.64	1.27	2.39	
	Rated speed nN (rpm)	3000	3000	3000	
	Rated current In (A)	1.4	2.4	3.8	
	Maximum torque Tm (N.m)	1.92	3.81	7.17	
Maximum current Im (A)	4.2	7.2	11.4		
Standstill torque Ts (N.m)	0.7	1.4	2.63		
Standstill current Is (A)	1.5	2.6	4.2		
Resistance Line - Line RL (Ω)	11.2	5.8	2.1		
Inductance Line - Line LL (mH)	20.9	11.5	10.5		
Electrical time constant τe (ms)	1.87	1.98	5		
Mechanical time constant τm (ms)		1.8	1.29	0.9	
		1.85 (with brake)	1.3 (with brake)	0.9 (with brake)	
Reverse voltage constant Ke (V/krpm)	29	34	40		
Torque constant kt (N.m/A)	0.48	0.562	0.662		
Rotor moment of inertia Jm (Kg·cm <sup>2</sup> )		0.214	0.405	1.087	
		0.218 (with brake)	0.409 (with brake)	1.099 (with brake)	
Brake holding torque T (Nm)	1.5	1.5	3.2		
Pole pair number	3	3	3		
Maximum voltage rising du/dt (kv/μs)	8	8	8		
Insulation class	F	F	F		
Maximum radial force Fr (N)	180	180	335		
Maximum axial force Fa (N)	90	90	167.5		
Weight G (Kg)		1.2	1.6	2.8	
		1.6 (with brake)	2.1 (with brake)	3.4 (with brake)	
Length of motor L (mm)		91±1.5	117±1.5	128.5±1.5	
		121±1.5 (with brake)	147±1.5 (with brake)	158±1.5 (with brake)	
Position feedback device	SMC series-16 bit single-turn magnetoelectric encoder; SMS series-Multi-turn absolute encoder				
Cooling method	Totally enclosed, non - ventilated				
Protection level	IP65, shaft sealing IP54 (Note: Add oil seal IP54 at the shaft end and do not add oil seal IP50)				
Environment conditions for operation	Temperature	-20~40°C (non-freezing)			
	Humidity	Below 90% RH (no condensation)			
	Ambient environment	Away from active gas, combustible gas, oil drops and dust			
	Altitude	Maximum altitude 4000m, rated power at 1000m or below. Above 1000m, decreasing 1.5% per every 100m rise			

Note: □ = A : Motor without brake  
 □ = B : Motor with brake

## ■ Technical Specifications of Servo Motor



Model parameter		Medium inertia, flang size of 130mm		
Servo motor		SMC130D-0100-20G□K-4LSP SMS130D-0100-20K□K-4LKP	SMC130D-0150-20G□K-4LSP SMS130D-0150-20K□K-4LKP	SMC130D-0200-20G□K-4LSP SMS130D-0200-20K□K-4LKP
Available driver		CD433-AA-000 FD433-LA-000 FD433-CA-000 FD433-EA-000		
DC link voltage VDC		300	300	300
Continuous performance	Rated power Pn (W)	1	1.5	2
	Rated torque Tn (N.m)	4.8	7.2	9.6
	Rated speed nN (rpm)	2000	2000	2000
	Rated current In (A)	4.4	6.8	8.8
Maximum torque Tm (N.m)	12	18	24	
Maximum current Im (A)	13.2	20.4	26.4	
Standstill torque Ts (N.m)	5.28	7.92	10.56	
Standstill current Is (A)	4.84	7.48	9.68	
Resistance Line - Line RL (Ω)	3.1	1.51	0.93	
Inductance Line - Line LL (mH)	24.07	13.8	8.8	
Electrical time constant τe (ms)	7.76	9.14	9.46	
Mechanical time constant τm (ms)		2.72	2.28	1.97
		2.76 (with brake)	2.3 (with brake)	1.98 (with brake)
Reverse voltage constant Ke (V/krpm)	73	71	72.8	
Torque constant kt (N.m/A)	1.21	1.17	1.2	
Rotor moment of inertia Jm (Kg·cm <sup>2</sup> )		7.4	12	17.7
		7.5 (with brake)	12.1 (with brake)	17.8 (with brake)
Brake holding torque T (Nm)	10	10	10	
Pole pair number	4	4	4	
Maximum voltage rising du/dt (kv/μs)	8	8	8	
Insulation class	F	F	F	
Maximum radial force Fr (N)	900	900	900	
Maximum axial force Fa (N)	450	450	450	
Weight G (Kg)		6.2	7.5	9.1
		8.5 (with brake)	9.8 (with brake)	11.4 (with brake)
Length of motor L (mm)		143±1.5	159±1.5	179±1.5
		204±1.5 (with brake)	220±1.5 (with brake)	240±1.5 (with brake)
Position feedback device	SMC series-16 bit single-turn magnetoelectric encoder; SMS series-Multi-turn absolute encoder			
Cooling method	Totally enclosed, non - ventilated			
Protection level	IP65, shaft sealing IP54 (Note: Add oil seal IP54 at the shaft end and do not add oil seal IP50)			
Environment conditions for operation	Temperature	-20~40°C (non-freezing)		
	Humidity	Below 90% RH (no condensation)		
	Ambient environment	Away from active gas, combustible gas, oil drops and dust		
	Altitude	Maximum altitude 4000m, rated power at 1000m or below. Above 1000m, decreasing 1.5% per every 100m rise		

Note: □ = A : Motor without brake  
 □ = B : Motor with brake

## ■ Technical Specifications of Servo Motor



Model parameter		Medium inertia, flang size of 130mm			
Servo motor		SMC130D-0100-20G□K-4HSP	SMC130D-0150-20G□K-4HSP SMS130D-0150-20K□K-4HKP	SMC130D-0200-20G□K-4HSP SMS130D-0200-20K□K-4HKP	SMC130D-0300-20G□K-4HSP SMS130D-0300-20K□K-4HKP
Available driver		CD623-AA-000 FD623-LA-000 FD623-CA-000 FD623-EA-000			
DC link voltage VDC		560	560	560	560
Continuous performance	Rated power Pn (W)	1	1.5	2	3
	Rated torque Tn (N.m)	4.8	7.2	9.6	14.3
	Rated speed nN (rpm)	2000	2000	2000	2000
	Rated current In (A)	2.27	4.5	6.2	6.7
Maximum torque Tm (N.m)	12	18	24	35.75	
Maximum current Im (A)	6.81	13.5	18.6	20.1	
Standstill torque Ts (N.m)	5.28	7.92	10.56	15.73	
Standstill current Is (A)	2.5	4.95	6.82	7.37	
Resistance Line - Line RL (Ω)	11.87	3.44	1.72	1.74	
Inductance Line - Line LL (mH)	88.81	31.26	17.1	18.9	
Electrical time constant τe (ms)	7.48	9.09	9.9	10.86	
Mechanical time constant τm (ms)		2.8	2.33	1.85	1.59
		2.84 (with brake)	2.35 (with brake)	1.86 (with brake)	1.59 (with brake)
Reverse voltage constant Ke (V/krpm)	141	106	102	142	
Torque constant kt (N.m/A)	2.33	1.75	1.69	2.35	
Rotor moment of inertia Jm (Kg·cm <sup>2</sup> )		7.4	12	17.7	29.1
		7.5 (with brake)	12.1 (with brake)	17.8 (with brake)	29.2 (with brake)
Brake holding torque T (Nm)	10	10	10	15	
Pole pair number	4	4	4	4	
Maximum voltage rising du/dt (kv/μs)	8	8	8	8	
Insulation class	F	F	F	F	
Maximum radial force Fr (N)	900	900	900	900	
Maximum axial force Fa (N)	450	450	450	450	
Weight G (Kg)		6.2	7.5	9.1	12.3
		8.5 (with brake)	9.8 (with brake)	11.4 (with brake)	14.9 (with brake)
Length of motor L (mm)		143±1.5	159±1.5	179±1.5	219±1.5
		204±1.5 (with brake)	220±1.5 (with brake)	240±1.5 (with brake)	280±1.5 (with brake)
Position feedback device	SMC series-16 bit single-turn magnetoelectric encoder; SMS series-Multi-turn absolute encoder				
Cooling method	Totally enclosed, non - ventilated				
Protection level	IP65, shaft sealing IP54 (Note: Add oil seal IP54 at the shaft end and do not add oil seal IP50)				
Environment conditions for operation	Temperature	-20~40°C (non-freezing)			
	Humidity	Below 90% RH (no condensation)			
	Ambient environment	Away from active gas, combustible gas, oil drops and dust			
	Altitude	Maximum altitude 4000m, rated power at 1000m or below. Above 1000m, decreasing 1.5% per every 100m rise			

Note: □ = A : Motor without brake  
 □ = B : Motor with brake

# Torque curve of servo motor

SMC40S-0005-30M□K-5LSU  
SMS40S-0005-30K□K-5LSU AC220V/ **50W**

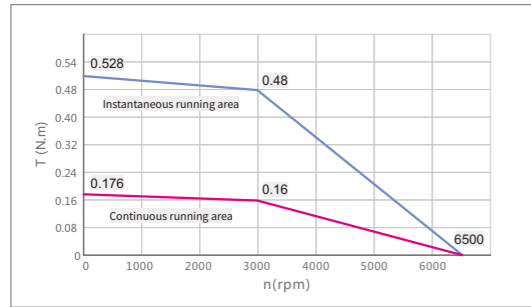

SMC40S-0010-30M□K-5LSU  
SMS40S-0010-30K□K-5LSU AC220V/ **100W**

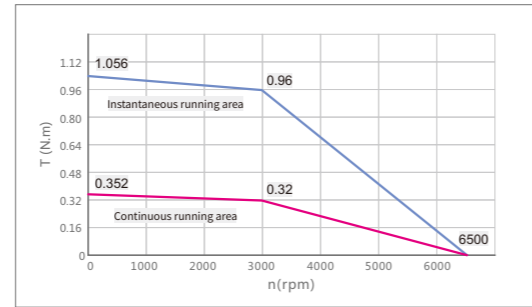

# Torque curve of servo motor

SMC130D-0100-20G□K-4HSP AC380V/ **1kW**

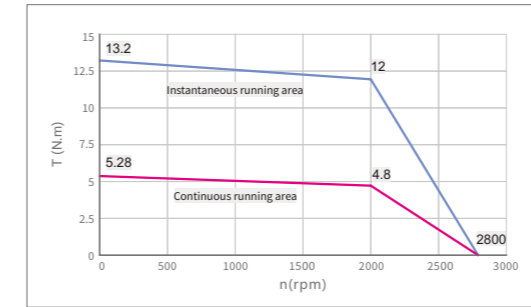

SMC130D-0150-20G□K-4LSP  
SMS130D-0150-20K□K-4LKP AC220V/ **1.5kW**

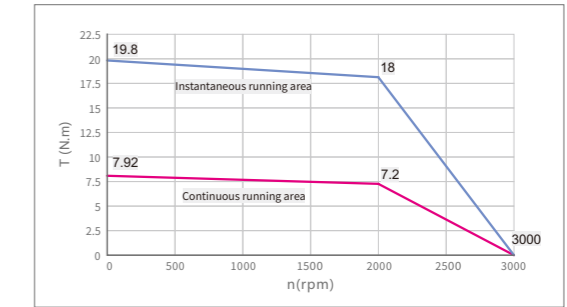

SMC60S-0020-30M□K-3LSU  
SMS60S-0020-30K□K-3LSU AC220V/ **200W**

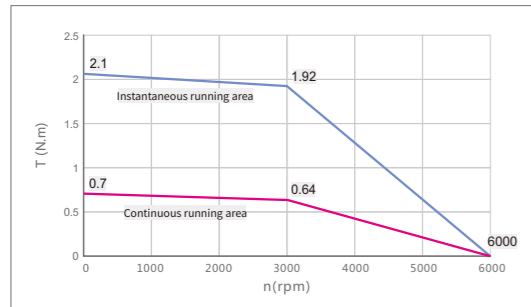

SMC60S-0040-30M□K-3LSU  
SMS60S-0040-30K□K-3LSU AC220V/ **400W**

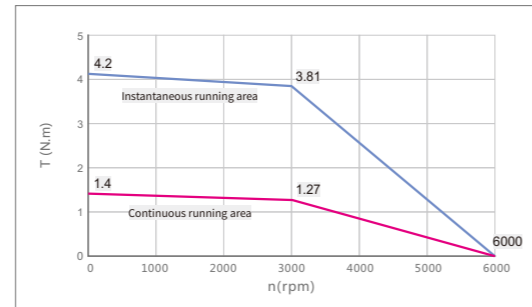

SMC130D-0150-20G□K-4HSP  
SMS130D-0150-20K□K-4HSP AC380V/ **1.5kW**

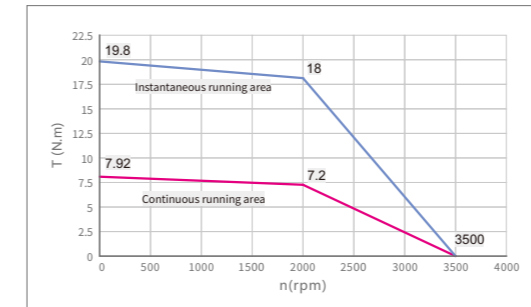

SMC130D-0200-20G□K-4LSP  
SMS130D-0200-20K□K-4LKP AC220V/ **2kW**

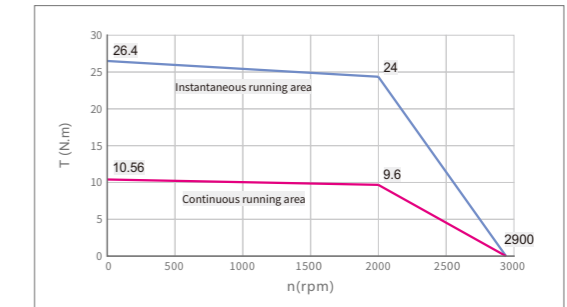

SMC80S-0075-30M□K-3LSU  
SMS80S-0075-30K□K-3LSU AC220V/ **750W**

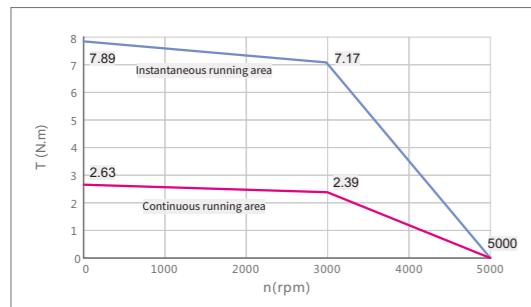

SMC130D-0100-20G□K-4LSP  
SMS130D-0100-20K□K-4LKP AC220V/ **1kW**

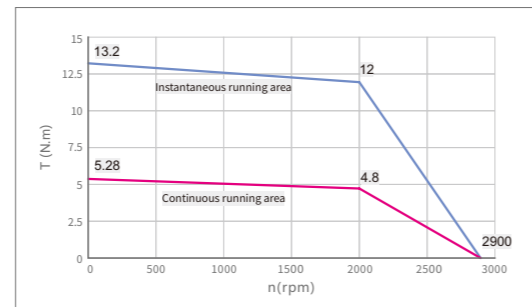

SMC130D-0200-20G□K-4HSP  
SMS130D-0200-20K□K-4HSP AC380V/ **2kW**

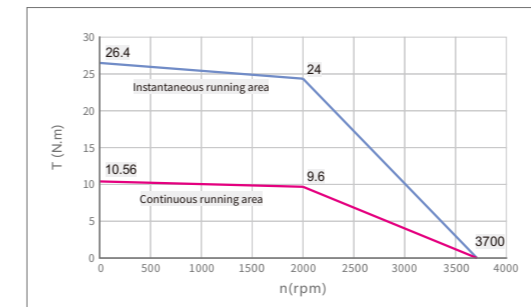

SMC130D-0300-20G□K-4HSP  
SMS130D-0300-20K□K-4HSP AC380V/ **3kW**

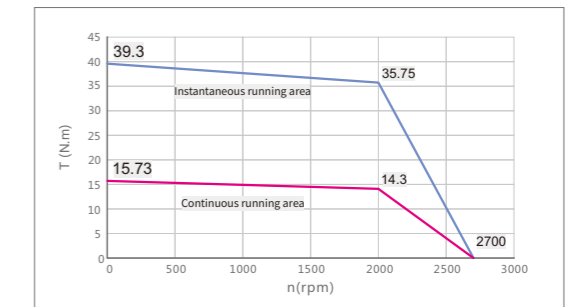



# Motor Dimensions Unit: mm

## Motor of flange size 40mm

Motor model	Length of motor L (mm)
SMC40S-0005-30MAK-5LSU	74.6±1.5
SMS40S-0005-30KAK-5LSU	96.6±1.5
SMC40S-0010-30MAK-5LSU	96.6±1.5
SMS40S-0010-30KAK-5LSU	96.6±1.5

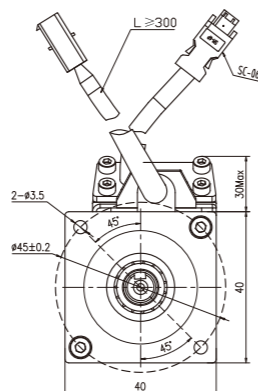
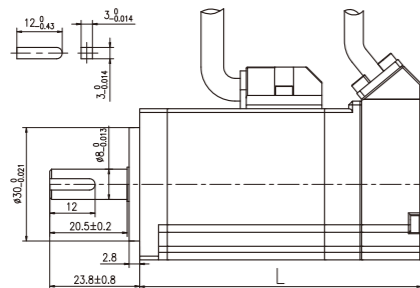

## Motor of flange size 40mm (with brake)

Motor model	Length of motor L (mm)
SMC40S-0005-30MBK-5LSU	104.6±1.5
SMS40S-0005-30KBK-5LSU	126.6±1.5
SMC40S-0010-30MBK-5LSU	126.6±1.5
SMS40S-0010-30KBK-5LSU	126.6±1.5

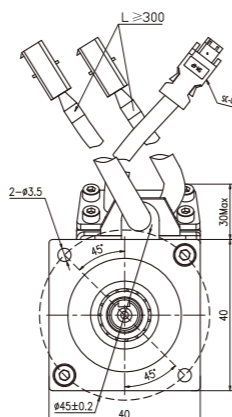
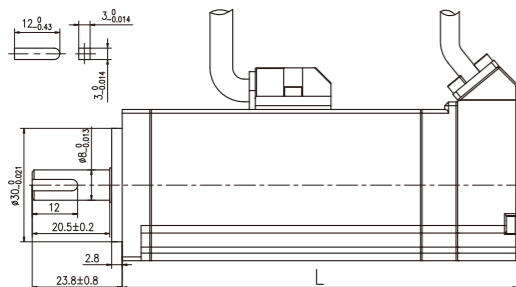

## Motor power cable

PIN	Signal	Color
1	U	Yellow
2	V	Red
3	W	Black
4	PE	Yellow/Green

Housing: H66L6-04P  
Terminal: T66L6-A

## Motor brake cable

PIN	Signal	Color
1	BRAKE (+)	Red
2	BRAKE (-)	Blue

Housing: H66L6-02P  
Terminal: T66L6-B

## Motor encoder cable

PIN	(SMS) Absolute encoder		(SMC) Magnetolectric encoder	
	Signal	Color	Signal	Color
1	VCC +5V	White	VDD	Red
2	GND	Black	GND	Black
3	VB	Orange	MA_P+	Brown
4	GND	Brown	MA_N-	Blue
5	SD	Blue	SLO_P+	Yellow
6	/SD	Purple	SLO_N-	Green

SC-06

# Motor Dimensions Unit: mm

## Motor of flange size 60mm

Motor model	Length of motor L (mm)
SMC60S-0020-30MAK-3LSU	91±1.5
SMS60S-0020-30KAK-3LSU	117±1.5
SMC60S-0040-30MAK-3LSU	117±1.5
SMS60S-0040-30KAK-3LSU	117±1.5

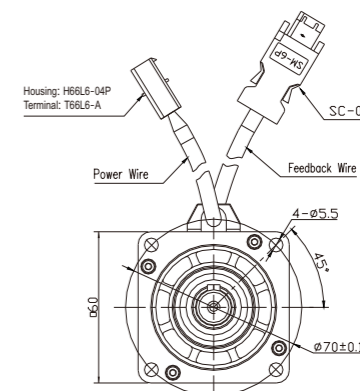
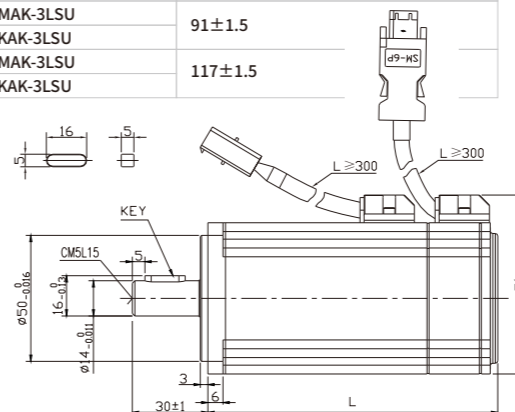

## Motor of flange size 60mm (with brake)

Motor model	Length of motor L (mm)
SMC60S-0020-30MBK-3LSU	121±1.5
SMS60S-0020-30KBK-3LSU	147±1.5
SMC60S-0040-30MBK-3LSU	147±1.5
SMS60S-0040-30KBK-3LSU	147±1.5

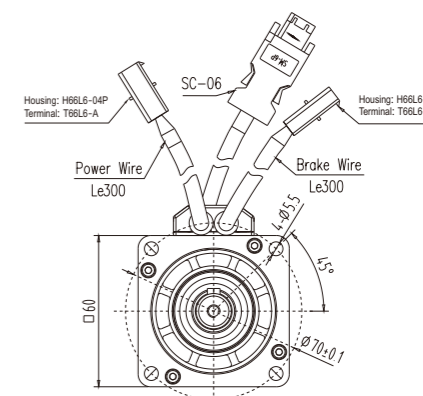
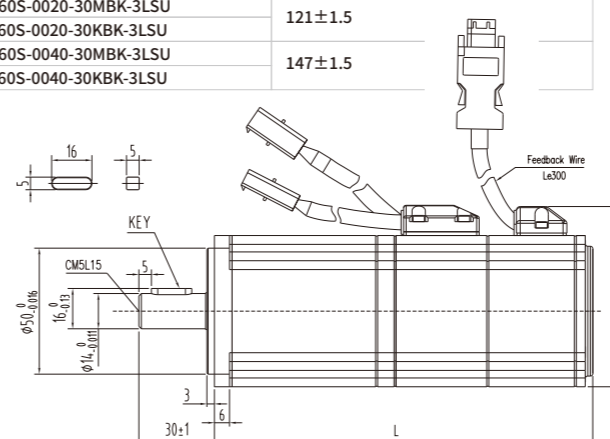

## Motor power cable

PIN	Signal	Color
1	U	Yellow
2	V	Red
3	W	Black
4	PE	Yellow/Green

Housing: H66L6-04P  
Terminal: T66L6-A

## Motor brake cable

PIN	Signal	Color
1	BRAKE (+)	Red
2	BRAKE (-)	Blue

Housing: H66L6-02P  
Terminal: T66L6-B

## Motor encoder cable

PIN	(SMS) Absolute encoder		(SMC) Magnetolectric encoder	
	Signal	Color	Signal	Color
1	VCC +5V	White	VDD	Red
2	GND	Black	GND	Black
3	VB	Orange	MA_P+	Brown
4	GND	Brown	MA_N-	Blue
5	SD	Blue	SLO_P+	Yellow
6	/SD	Purple	SLO_N-	Green

SC-06

■ Motor Dimensions Unit: mm

Motor of flange size 80mm

Motor model	Length of motor L (mm)
SMC80S-0075-30MAK-3LSU	128.5±1.5
SMS80S-0075-30KAK-3LSU	

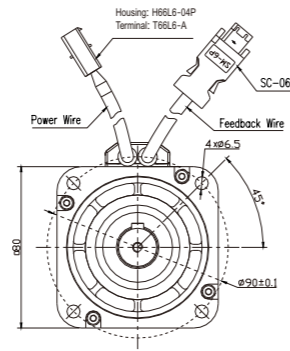
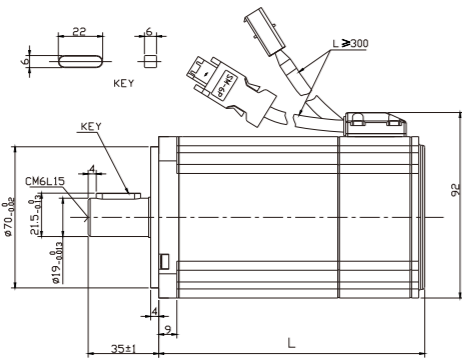

Motor of flange size 80mm (with brake)

Motor model	Length of motor L (mm)
SMC80S-0075-30MBK-3LSU	158±1.5
SMS80S-0075-30KBK-3LSU	

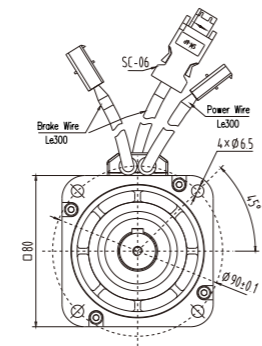
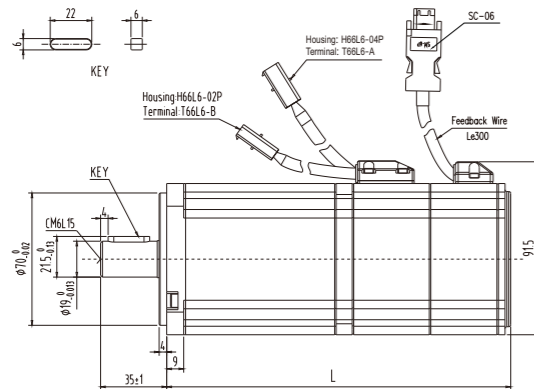

Motor power cable

PIN	Signal		Color
	1	U	Yellow
2	V	Red	
3	W	Black	
4	PE	Yellow/Green	

Housing: H66L6-04P  
Terminal: T66L6-A

Motor brake cable

PIN	Signal		Color
	1	BRAKE (+)	Red
2	BRAKE (-)	Blue	

Housing: H66L6-02P  
Terminal: T66L6-B

Motor encoder cable

PIN	(SMS) Absolute encoder		(SMC) Magnetolectric encoder	
	Signal	Color	Signal	Color
1	VCC +5V	White	VDD	Red
2	GND	Black	GND	Black
3	VB	Orange	MA_P+	Brown
4	GND	Brown	MA_N-	Blue
5	SD	Blue	SLO_P+	Yellow
6	/SD	Purple	SLO_N-	Green

SC-06

■ Motor Dimensions Unit: mm

Aviation socket motor of flange size 130mm

Motor model	Length of motor L (mm)
SMS130D-0100-20KAK-4LKP	143±1.5
SMS130D-0150-20KAK-4LKP	159±1.5
SMS130D-0150-20KAK-4HKP	
SMS130D-0200-20KAK-4LKP	179±1.5
SMS130D-0200-20KAK-4HKP	
SMS130D-0300-20KAK-4HKP	219±1.5

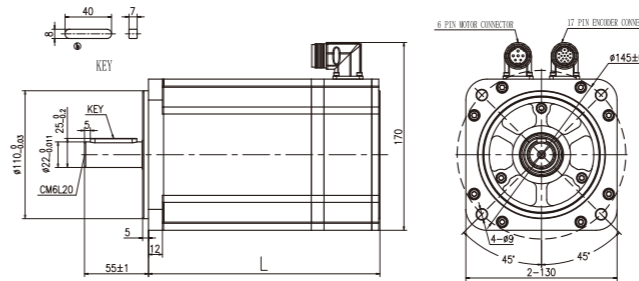

Aviation socket motor of flange size 130mm (with brake)

Motor model	Length of motor L (mm)
SMS130D-0100-20KBK-4LKP	204±1.5
SMS130D-0150-20KBK-4LKP	220±1.5
SMS130D-0150-20KBK-4HKP	
SMS130D-0200-20KBK-4LKP	240±1.5
SMS130D-0200-20KBK-4HKP	
SMS130D-0300-20KBK-4HKP	280±1.5

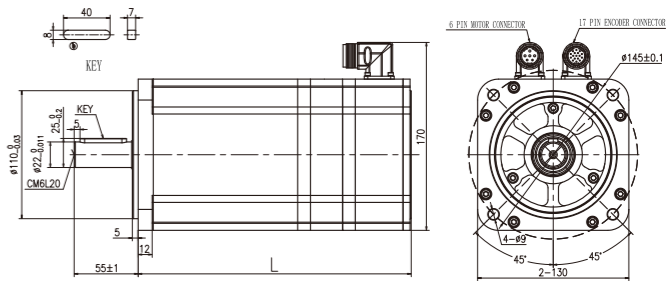

Aviation socket motor of flange size 130mm

Motor model	Length of motor L (mm)
SMC130D-0100-20GAK-4LSP	143±1.5
SMC130D-0100-20GAK-4HSP	
SMC130D-0150-20GAK-4LSP	159±1.5
SMC130D-0150-20GAK-4HSP	
SMC130D-0200-20GAK-4LSP	179±1.5
SMC130D-0200-20GAK-4HSP	
SMC130D-0300-20GAK-4HSP	219±1.5

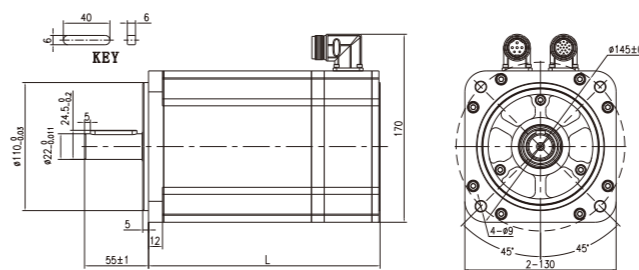

Aviation socket motor of flange size 130mm (with brake)

Motor model	Length of motor L (mm)
SMC130D-0100-20GBK-4LSP	204±1.5
SMC130D-0100-20GBK-4HSP	
SMC130D-0150-20GBK-4LSP	220±1.5
SMC130D-0150-20GBK-4HSP	
SMC130D-0200-20GBK-4LSP	240±1.5
SMC130D-0200-20GBK-4HSP	
SMC130D-0300-20GBK-4HSP	280±1.5

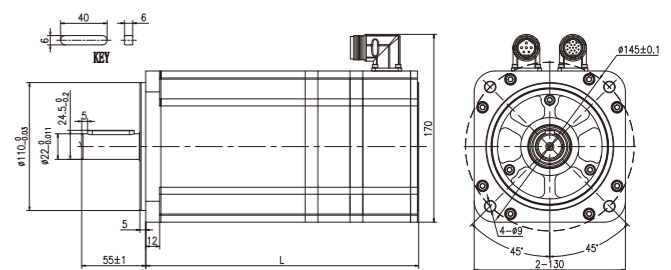

# Cable wiring instructions

## ENCDG-(4)-GU-BT

Wire spec.: 3×2×0.2mm<sup>2</sup>

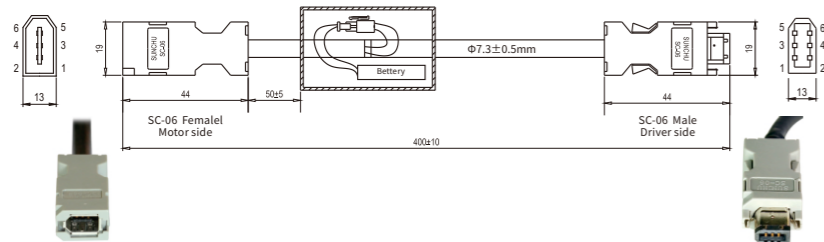

## ENCDGF-LL-GU

Wire spec.: UL2661 1P×20AWG(72/0.10T)+2P×24AWG(32/0.10T)  
20AWG cross section area is 0.5189mm<sup>2</sup>  
24AWG cross section area is 0.2047mm<sup>2</sup>

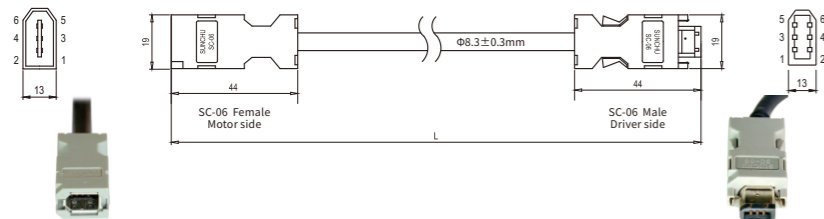

## ENCDG-LL-GU

Wire spec.: UL2661 1P×20AWG+2P×24AWG  
20AWG cross section area is 0.5189mm<sup>2</sup>  
24AWG cross section area is 0.2047mm<sup>2</sup>

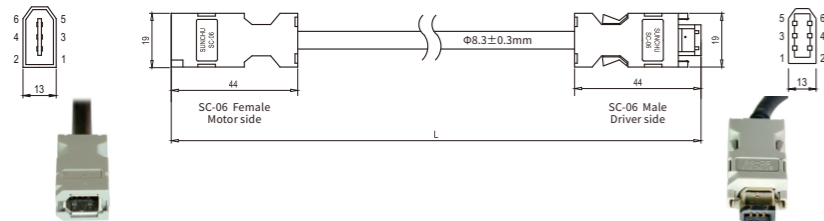

## ENCDG-LL-GC0

Wire spec.: UL2661 1P×20AWG(72/0.10T)+2P×24AWG(32/0.10T)  
20AWG cross section area is 0.5189mm<sup>2</sup>  
24AWG cross section area is 0.2047mm<sup>2</sup>

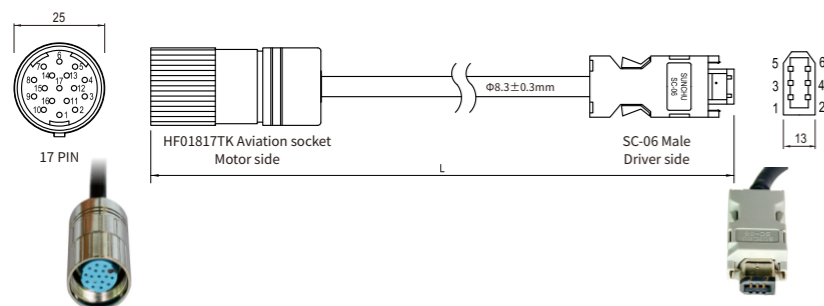

SC-06F	Color	Black HSG	Ext. single cable	Signal	SC-06 M
PIN1	Red			+5V	PIN1
PIN2	Black			GND	PIN2
PIN3	Brown	PIN1	Red	BAT+	
PIN4	Blue	PIN2	Black	BAT-	
PIN5	Yellow			SD	PIN5
PIN6	Green			/SD	PIN6
Shell	Shield			Shield	Shell

SC-06	Color	Signal 1	Signal 2
PIN1	Red	VDD	+5V
PIN2	Black	GND	GND
PIN3	Brown	MA_P+	BAT+
PIN4	Blue	MA_N-	BAT-
PIN5	Yellow	SLO_P+	SD
PIN6	Green	SLO_N-	/SD
Shell	Shield	Shield	Shield

Note: Signal 1 is suitable for SMC series magnetolectric encoder motor.  
Signal 2 is suitable for SMS series motor.

SC-06	Color	Signal 1	Signal 2
PIN1	Red	VDD	+5V
PIN2	Black	GND	GND
PIN3	Brown	MA_P+	BAT+
PIN4	Blue	MA_N-	BAT-
PIN5	Yellow	SLO_P+	SD
PIN6	Green	SLO_N-	/SD
Shell	Shield	Shield	Shield

Note: Signal 1 is suitable for SMC series magnetolectric encoder motor.  
Signal 2 is suitable for SMS series motor.

HF01817TK	Color	Signal 1	Signal 2	SC-06
PIN1	Red	VDD	VDD	PIN1
PIN2	Black	GND	GND	PIN2
PIN3	Brown	MA_P+	BAT+	PIN3
PIN4	Blue	MA_N-	BAT-	PIN4
PIN16	Yellow	SLO_P+	SD	PIN5
PIN17	Green	SLO_N-	/SD	PIN6
Shell	Shield	Shield	Shield	Shell

Note: Signal 1 is suitable for SMC series magnetolectric encoder motor.  
Signal 2 is suitable for SMS series motor.

# Cable wiring instructions

## ENCDGF-LL-GC0

Wire spec.: UL2661 1P×20AWG(26/0.16T)+2P×24AWG(11/0.16T)  
20AWG cross section area is 0.5189mm<sup>2</sup>  
24AWG cross section area is 0.2047mm<sup>2</sup>

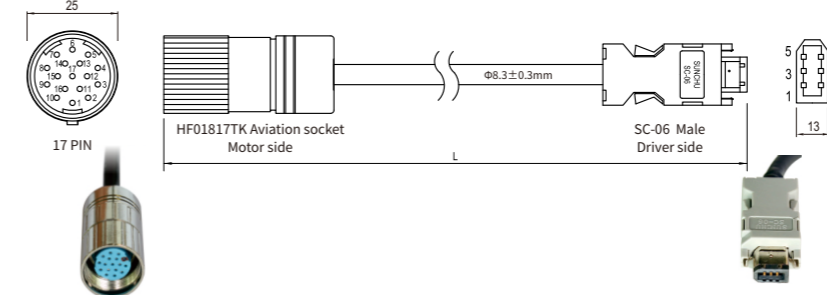

## MOT-005-LL-KL-Y

Wire spec.: UL20328 4C×18AWG(41/0.16T) black  
18AWG cross section area is 0.8107mm<sup>2</sup>

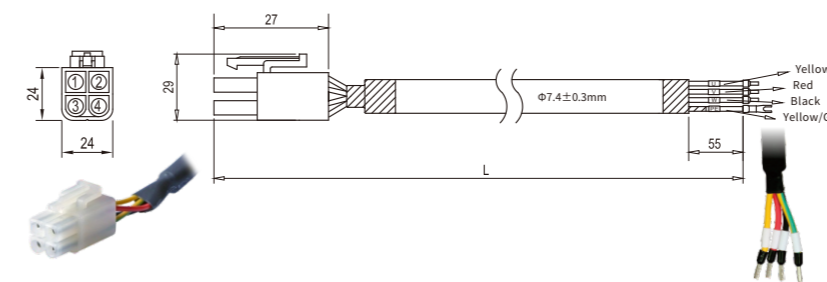

## MOTF-005-LL-KL-Y

Wire spec.: UL2661 4C×18AWG(7/18/0.10T) black  
18AWG cross section area is 0.8107mm<sup>2</sup>

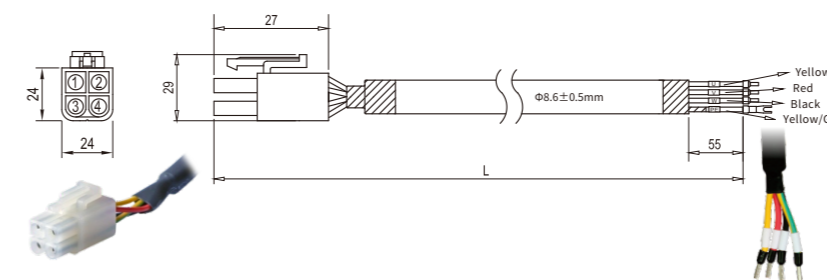

## MOT-008-LL-KC4

Wire spec.: UL2586 4×16AWG  
16AWG cross section area is 1.318mm<sup>2</sup>

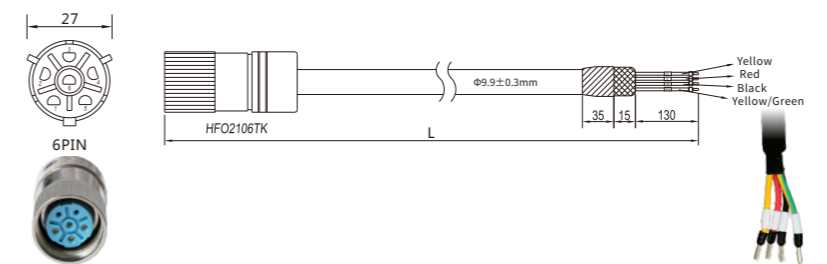

HF01817TK	Color	Signal 1	Signal 2	SC-06
PIN1	Red	VDD	VDD	PIN1
PIN2	Black	GND	GND	PIN2
PIN3	Brown	MA_P+	BAT+	PIN3
PIN4	Blue	MA_N-	BAT-	PIN4
PIN16	Yellow	SLO_P+	SD	PIN5
PIN17	Green	SLO_N-	/SD	PIN6
Shell	Shield	Shield	Shield	Shell

Note: Signal 1 is suitable for SMC series magnetolectric encoder motor.  
Signal 2 is suitable for SMS series motor.

Color	Signal	HSG plug
Yellow	U	PIN1
Red	V	PIN2
Black	W	PIN3
Yellow/Green	PE	PIN4

Color	Signal	HSG Plug
Yellow	U	PIN1
Red	V	PIN2
Black	W	PIN3
Yellow/Green	PE	PIN4

Color	Signal	HF02106TK
Yellow	U	PIN2
Red	V	PIN3
Black	W	PIN4
Yellow/Green	PE	PIN6

## Cable wiring instructions

### MOT-005-LL-KC4-B

Wire spec.: RVVYP 4\*18AWG+2\*20AWG BLACK  
18AWG cross section area is 0.8107mm<sup>2</sup>  
20AWG cross section area is 0.5189mm<sup>2</sup>

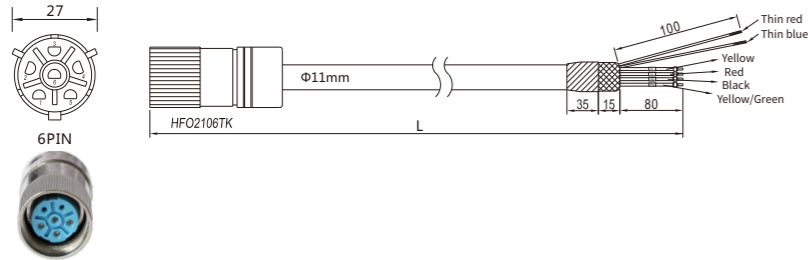

### MOT-008-LL-KC4-B

Wire spec. : RVVYP 4×1.5mm<sup>2</sup>+2×0.5mm<sup>2</sup>

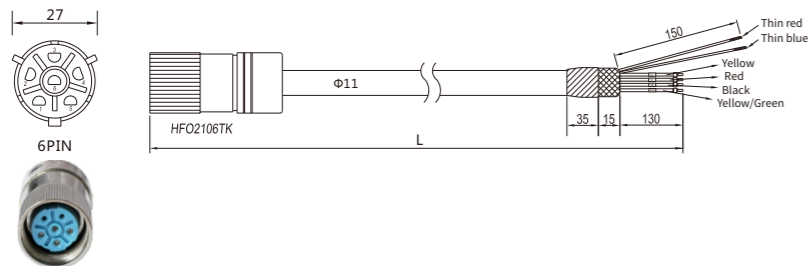

### BRA-LL-KL

Wire spec.: UL2464 2C\*20AWG  
20AWG cross section area is 0.5189mm<sup>2</sup>

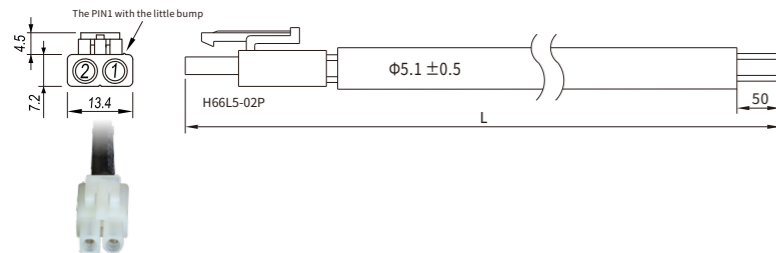

### BRAF-LL-KL

Wire spec.: EKM71373 2\*20AWG BLACK  
20AWG cross section area is 0.5189mm<sup>2</sup>

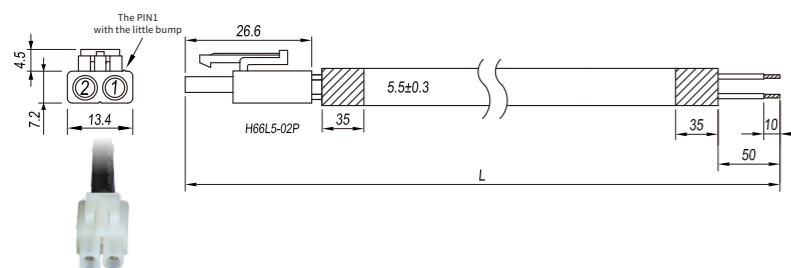

Color	Signal	HFO2106TK
Yellow	U	PIN2
Red	V	PIN3
Black	W	PIN4
Yellow/Green	PE	PIN6
Thin red	brake+	PIN1
Thin blue	brake-	PIN5
Shield	Shield	Shell

Color	Signal	HFO2106TK
Yellow	U	PIN2
Red	V	PIN3
Black	W	PIN4
Yellow/Green	PE	PIN6
Thin red	brake+	PIN1
Thin blue	brake-	PIN5

Color	Signal	2PIN plug
Red	brake+	PIN1
Blue	brake-	PIN2

Color	Signal	2PIN plug
Red	brake+	PIN1
Blue	brake-	PIN2

## Driver, Motor and Cable Selection Table

Series	Rated power/ Rated speed/ Rated torque	Servo Motor	Description	Servo Driver				Power/ Brake Cable	Encoder Cable		
				EtherCAT	CANopen	Modbus 485	Pulse				
SMS Series	50W 3000rpm 0.16Nm	SMS40S-0005-30KAK-5LSU	Multi-turn absolute encoder	FD413-EA-000	FD413-CA-000	FD413-LA-000	CD413-AA-000	MOT-005-LL-KL-Y	ENC DG- LL-GU ENC DG- (4)-GU- BT★		
	100W 3000rpm 0.32Nm	SMS40S-0005-30KAK-5LSU	Multi-turn absolute encoder					MOT-005-LL-KL-Y/BRA-LL-KL			
	100W 3000rpm 0.32Nm	SMS40S-0010-30KAK-5LSU	Multi-turn absolute encoder					MOT-005-LL-KL-Y			
	200W 3000rpm 0.64Nm	SMS40S-0010-30KAK-5LSU	Multi-turn absolute encoder					MOT-005-LL-KL-Y/BRA-LL-KL			
	400W 3000rpm 1.27Nm	SMS60S-0020-30KAK-3LSU	Multi-turn absolute encoder					MOT-005-LL-KL-Y			
	400W 3000rpm 1.27Nm	SMS60S-0020-30KAK-3LSU	Multi-turn absolute encoder					MOT-005-LL-KL-Y/BRA-LL-KL			
	750W 3000rpm 2.39Nm	SMS80S-0075-30KAK-3LSU	Multi-turn absolute encoder	FD423-EA-000	FD423-CA-000	FD423-LA-000	CD423-AA-000	MOT-005-LL-KL-Y			
	750W 3000rpm 2.39Nm	SMS80S-0075-30KAK-3LSU	Multi-turn absolute encoder					MOT-005-LL-KL-Y/BRA-LL-KL			
	1kW 2000rpm 4.8Nm	SMS130D-0100-20KAK-4LKP	Multi-turn absolute aviation socket encoder					MOT-005-LL-KC4			
	1.5kW 2000rpm 7.2Nm	SMS130D-0100-20KAK-4LKP*	Multi-turn absolute aviation socket encoder					MOT-005-LL-KC4-B			
	1.5kW 2000rpm 7.2Nm	SMS130D-0150-20KAK-4LKP	Multi-turn absolute aviation socket encoder					MOT-008-LL-KC4			
	1.5kW 2000rpm 7.2Nm	SMS130D-0150-20KAK-4LKP*	Multi-turn absolute aviation socket encoder					MOT-008-LL-KC4-B			
	2kW 2000rpm 10Nm	SMS130D-0200-20KAK-4LKP	Multi-turn absolute aviation socket encoder	FD433-EA-000	FD433-CA-000	FD433-LA-000	CD433-AA-000	MOT-008-LL-KC4			
	2kW 2000rpm 10Nm	SMS130D-0200-20KAK-4LKP*	Multi-turn absolute aviation socket encoder					MOT-008-LL-KC4-B			
	1.5kW 2000rpm 7.2Nm	SMS130D-0150-20KAK-4HKP	Multi-turn absolute aviation socket encoder					MOT-005-LL-KC4			
	1.5kW 2000rpm 7.2Nm	SMS130D-0150-20KAK-4HKP*	Multi-turn absolute aviation socket encoder					MOT-005-LL-KC4-B			
	2kW 2000rpm 10Nm	SMS130D-0200-20KAK-4HKP	Multi-turn absolute aviation socket encoder					MOT-008-LL-KC4			
	2kW 2000rpm 10Nm	SMS130D-0200-20KAK-4HKP*	Multi-turn absolute aviation socket encoder					MOT-008-LL-KC4-B			
3kW 2000rpm 14.3Nm	SMS130D-0300-20KAK-4HKP	Multi-turn absolute aviation socket encoder	FD623-EA-000	FD623-CA-000	FD623-LA-000	CD623-AA-000	MOT-008-LL-KC4				
3kW 2000rpm 14.3Nm	SMS130D-0300-20KAK-4HKP*	Multi-turn absolute aviation socket encoder					MOT-008-LL-KC4-B				
50W 3000rpm 0.16Nm	SMC40S-0005-30MAK-5LSU	16 bit single-turn Magnetolectric encoder					FD413-EA-000	FD413-CA-000	FD413-LA-000	CD413-AA-000	MOT-005-LL-KL-Y
50W 3000rpm 0.16Nm	SMC40S-0005-30MBK-5LSU	16 bit single-turn Magnetolectric encoder									MOT-005-LL-KL-Y/BRA-LL-KL
100W 3000rpm 0.32Nm	SMC40S-0010-30MAK-5LSU	16 bit single-turn Magnetolectric encoder									MOT-005-LL-KL-Y
100W 3000rpm 0.32Nm	SMC40S-0010-30MBK-5LSU	16 bit single-turn Magnetolectric encoder									MOT-005-LL-KL-Y/BRA-LL-KL
200W 3000rpm 0.64Nm	SMC60S-0020-30MAK-3LSU	16 bit single-turn Magnetolectric encoder	MOT-005-LL-KL-Y								
200W 3000rpm 0.64Nm	SMC60S-0020-30MBK-3LSU	16 bit single-turn Magnetolectric encoder	MOT-005-LL-KL-Y/BRA-LL-KL								
400W 3000rpm 1.27Nm	SMC60S-0040-30MAK-3LSU	16 bit single-turn Magnetolectric encoder	FD423-EA-000	FD423-CA-000	FD423-LA-000	CD423-AA-000	MOT-005-LL-KL-Y				
400W 3000rpm 1.27Nm	SMC60S-0040-30MBK-3LSU	16 bit single-turn Magnetolectric encoder					MOT-005-LL-KL-Y/BRA-LL-KL				
750W 3000rpm 2.39Nm	SMC80S-0075-30MAK-3LSU	16 bit single-turn Magnetolectric encoder					MOT-005-LL-KL-Y				
750W 3000rpm 2.39Nm	SMC80S-0075-30MBK-3LSU	16 bit single-turn Magnetolectric encoder					MOT-005-LL-KL-Y/BRA-LL-KL				
1kW 2000rpm 4.8Nm	SMC130D-0100-20GAK-4LSP	16 bit single-turn Magnetolectric aviation socket encoder					MOT-005-LL-KC4				
1kW 2000rpm 4.8Nm	SMC130D-0100-20GBK-4LSP*	16 bit single-turn Magnetolectric aviation socket encoder					MOT-005-LL-KC4-B				
1.5kW 2000rpm 7.2Nm	SMC130D-0150-20GAK-4LSP	16 bit single-turn Magnetolectric aviation socket encoder	FD433-EA-000	FD433-CA-000	FD433-LA-000	CD433-AA-000	MOT-008-LL-KC4				
1.5kW 2000rpm 7.2Nm	SMC130D-0150-20GBK-4LSP*	16 bit single-turn Magnetolectric aviation socket encoder					MOT-008-LL-KC4-B				
2kW 2000rpm 10Nm	SMC130D-0200-20GAK-4LSP	16 bit single-turn Magnetolectric aviation socket encoder					MOT-008-LL-KC4				
2kW 2000rpm 10Nm	SMC130D-0200-20GBK-4LSP*	16 bit single-turn Magnetolectric aviation socket encoder					MOT-008-LL-KC4-B				
1kW 2000rpm 4.8Nm	SMC130D-0100-20GAK-4HSP	16 bit single-turn Magnetolectric aviation socket encoder					MOT-005-LL-KC4				
1kW 2000rpm 4.8Nm	SMC130D-0100-20GBK-4HSP*	16 bit single-turn Magnetolectric aviation socket encoder					MOT-005-LL-KC4-B				
1.5kW 2000rpm 7.2Nm	SMC130D-0150-20GAK-4HSP	16 bit single-turn Magnetolectric aviation socket encoder	FD623-EA-000	FD623-CA-000	FD623-LA-000	CD623-AA-000	MOT-005-LL-KC4				
1.5kW 2000rpm 7.2Nm	SMC130D-0150-20GBK-4HSP*	16 bit single-turn Magnetolectric aviation socket encoder					MOT-005-LL-KC4-B				
2kW 2000rpm 10Nm	SMC130D-0200-20GAK-4HSP	16 bit single-turn Magnetolectric aviation socket encoder					MOT-008-LL-KC4				
2kW 2000rpm 10Nm	SMC130D-0200-20GBK-4HSP*	16 bit single-turn Magnetolectric aviation socket encoder					MOT-008-LL-KC4-B				
3kW 2000rpm 14.3Nm	SMC130D-0300-20GAK-4HSP	16 bit single-turn Magnetolectric aviation socket encoder					MOT-008-LL-KC4				
3kW 2000rpm 14.3Nm	SMC130D-0300-20GBK-4HSP*	16 bit single-turn Magnetolectric aviation socket encoder					MOT-008-LL-KC4-B				

Note: \* When the driver drives the band brake device, DC24V/2A relay shall be externally connected.

★ ENCDG-(4)-GU-BT is a battery-powered cable for the motor of the multi-loop absolute value encoder, with a length of 40cm.