

Ezi-SERVO[®] II

Closed Loop Stepping System

- Embedded Controller
- Ethernet Interface
- Position Table
- Closed Loop System
- No Gain Tuning / No Hunting
- High Resolution / Fast Response
- Heat Reduction / Torque Improvement

Plus-E



CE

FASTECH

Fast, Accurate, Smooth Motion



Fast, Accurate, Smooth Motion

Ezi-SERVO[®] II Plus-E

Closed Loop Stepping System

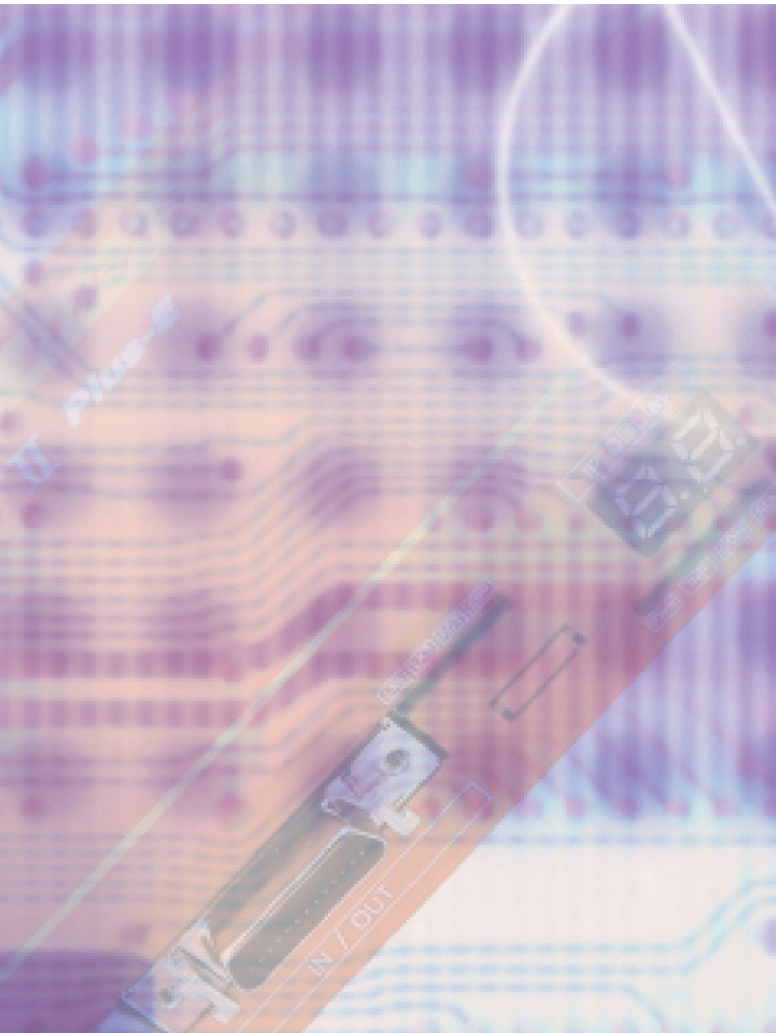

2 Position Table Function

Position Table can be used for motion control by digital input and output signals of host controller.

You can operate the motor directly by sending the position table number, start/stop, origin search and other digital input values from a PC.

The PC can monitor the In-Position, origin search, moving/stop, servo ready and other digital output signals from a drive. A maximum of 256 positioning points can be set from PC.

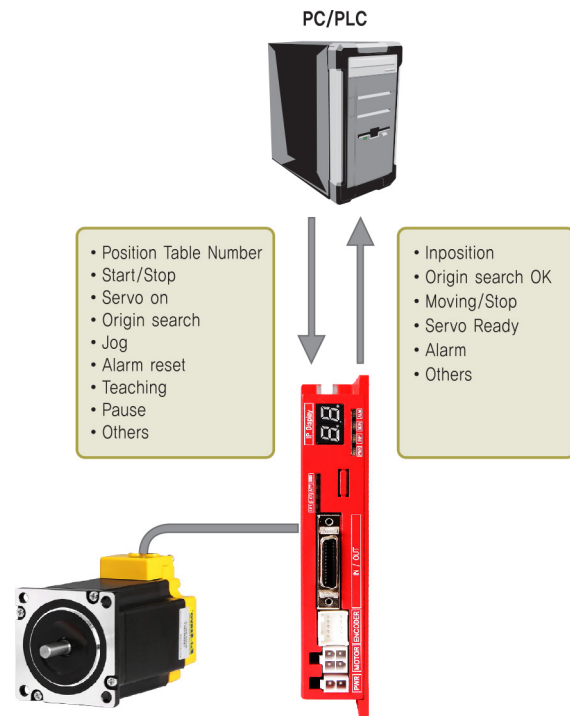

1 Network Based Motion Control

A maximum of 254 axes can be operated from a PC through Ethernet communications. And daisy-chain connection is available thru internally equipped Ethernet HUB. All of the Motion conditions are set through the network and saved in Flash ROM as a parameter. Motion Library(DLL) is provided for programming under Windows XP/7/8/10.

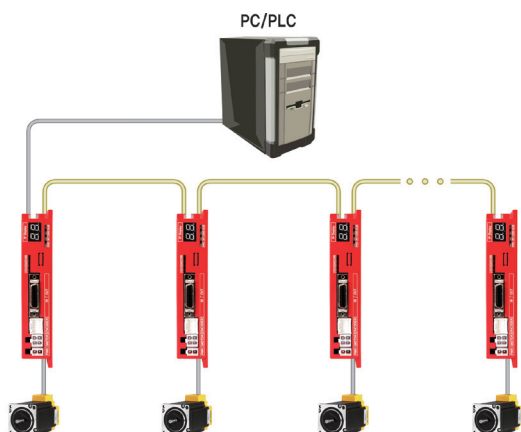

3 Closed Loop System

Ezi-SERVOII is an innovative closed loop stepping system that utilizes a high-resolution motor mounted encoder constantly to monitor the current position. The encoder feedback allows the Ezi-SERVOII to update the current position every 50 micro seconds. It allows the Ezi-SERVOII drive to compensate for the loss of position, ensuring accurate positioning. For example, due to a sudden load change, a conventional stepper motor and drive could lose a step but Ezi-SERVOII automatically correct the position by encoder feedback.

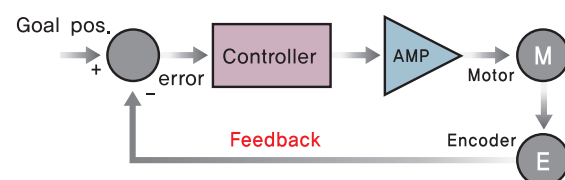

4 No Gain Tuning

To ensure machine performance, smoothness, positional error and low servo noise, Conventional servo systems require the adjustment of its servo's gains as an initial crucial step. Even systems that employ auto-tuning require manual tuning after the system is installed, especially if more than one axis are interdependent. Ezi-SERVOII employs the best characteristics of stepper, closed loop motion controls and algorithms to eliminate the need of tedious gain tuning required for conventional closed loop servo systems. This means that Ezi-SERVOII is optimized for the application and ready to work right out of the box. The Ezi-SERVOII system employs the unique characteristics of the closed loop stepping motor control, eliminating these cumbersome steps and giving the engineer a high performance servo system without wasting setup time. Ezi-SERVOII is especially well suited for low stiffness loads (for example, a belt and pulley system) that sometime require conventional servo systems to inertia match with the additional expensive and bulky gearbox. Ezi-SERVOII also performs exceptionally, even under heavy loads and high speeds.

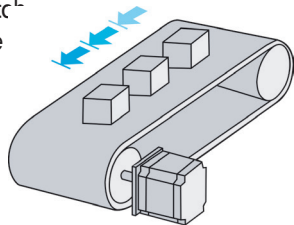

6 Torque Improvement

(Motor Voltage Increasing and Motor Current Setting)

Ezi-SERVOII boosts the voltage supplied to the motor by internal DC-DC Converter. The torque at the high speed is increased. In addition, it is possible to set the Run Current up to 150%, whereby the torque at low speed is increased. Torque can be improved by about 30% over the entire speed range.

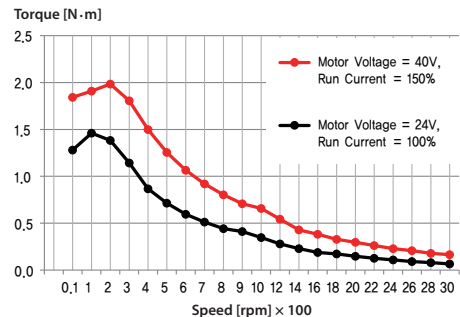

※ The torque at low speed and high speed is improved about 30%.

Measured Condition : Drive = Ezi-SERVOII-PE-56L
 Motor Voltage = 40VDC
 Input Voltage = 24VDC

5 Heat Reduction / Energy Saving

(Motor Current Control according to load)

Ezi-SERVOII automatically controls motor current according to load. Ezi-SERVOII reduces motor current when motor load is low, and increases motor current when load is high. By optimizing the motor current, motor heat can be minimized and energy can be saved.

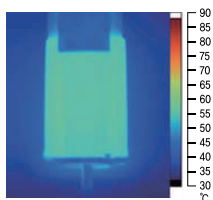

Motor temperature [Measured by Thermal Imaging Camera]

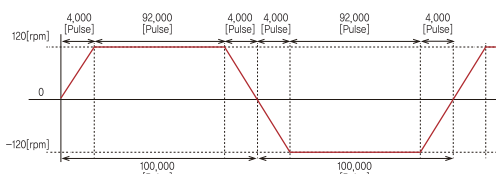

Condition to measure the motor temperature
 [4hours operation, Motor surface temperature saturation]

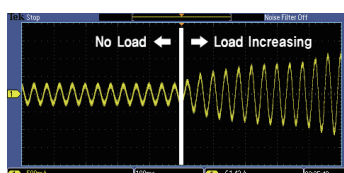

Example of the Motor Current Control according to load

7 No Hunting

Traditional servo motor drives overshoot their position and try to correct by overshooting the opposite direction, especially in high gain applications. This is called null hunt and is especially prevalent in systems that the break away or static friction is significantly higher than the running friction. The cure is lowering the gain, which affects accuracy or using Ezi-SERVOII Motion Control System. Ezi-SERVOII utilizes the unique characteristics of stepping motors and locks itself into the desired target position, eliminating Null Hunt. This feature is especially useful in applications such as nanotech manufacturing, semiconductor fabrication, vision systems and ink jet printing in which system oscillation and vibration could be a problem.

Complete stop

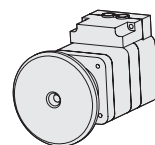

Hunting

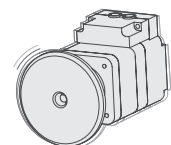

Ezi-SERVO

Servo motor

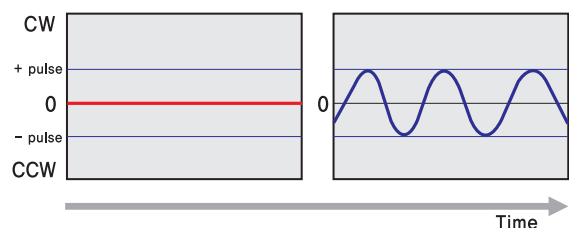

8 Smooth and Accurate

Ezi-SERVO II is a high-precision servo drive, using a high-resolution encoder with 20,000 pulses/revolution. Unlike a conventional Microstep drive, the on-board high performance ARM (Advanced RISC Machine) performs vector control and filtering, producing a smooth rotational control with minimum ripples.

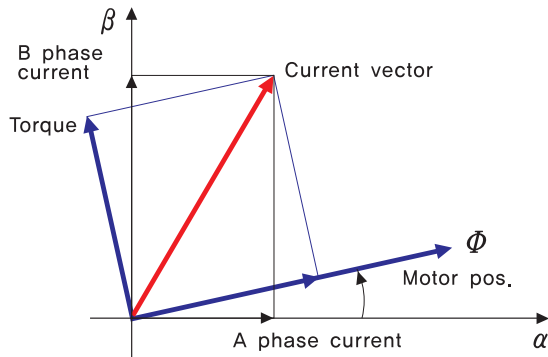

9 Fast Response

Similar to conventional stepping motors, Ezi-SERVO II instantly synchronizes with command pulses providing fast positional response. Ezi-SERVO II is the optimum choice when zero-speed stability and rapid motions within a short distance are required. Traditional servo motor systems have a natural delay called settling time between the command input signals and the resultant motion because of the constant monitoring of the current position.

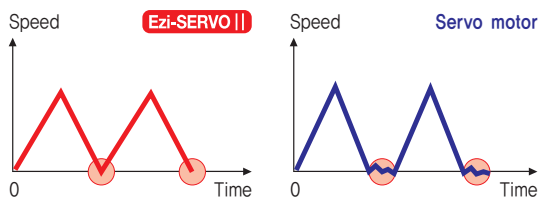

10 High Resolution

The unit of the position command can be divided precisely.

(Max. 20,000 pulses/revolution)

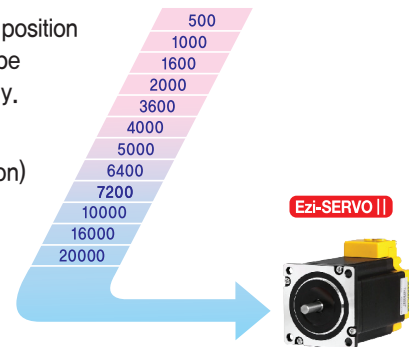

11 High Torque

Compared with common step motors and drives, Ezi-SERVO II motion control systems can maintain a high torque state over relatively long period of time. This means that Ezi-SERVO II continuously operates without loss of position under 100% of the load. Unlike conventional Microstep drives, Ezi-SERVO II exploits continuous high torque operation during high speed motion due to its innovative optimum current phase control.

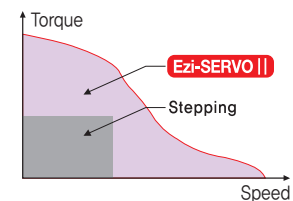

12 High Speed

The Ezi-SERVO II operates well at high speed without the loss of synchronism or positioning error. Ezi-SERVO II's ability of continuous current position monitoring of enables the stepping motor to generate high torque, even under a 100% load condition.

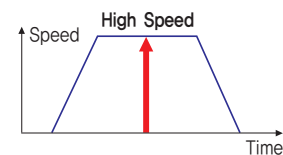

Advantages over Open-Loop Control Stepping Drive

1. Reliable positioning without loss of synchronism.
2. Holding stable position and automatically recovering to the original position even after experiencing positioning error due to external forces, such as mechanical vibration or vertical positional holding.
3. Ezi-SERVO II utilizes 100% of the full range of rated motor torque, contrary to a conventional open-loop stepping driver that can use up to 50% of the rated motor torque due to the loss of synchronism.
4. Capability to operate at high speed due to load-dependant current control, open-loop stepping drivers use a constant current control at all speed ranges without considering load variations.

Advantages over Servo Motor Controller

1. No gain tuning. (Automatic gain adjustment in response to a load change)
2. Maintains the stable holding position without oscillation after completion of positioning.
3. Fast positioning due to the independent control by on-board ARM.
4. Continuous operation during rapid short-stroke movement due to instantaneous positioning.

● Features of Motion Controller

1. Loop Count

This function allows positioning repeatedly according to the Loop Count Number.

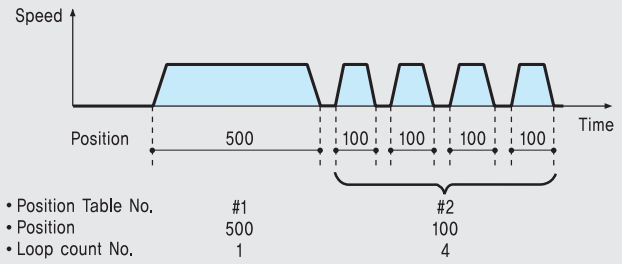

2. Acceleration/Deceleration

For quick acceleration and gradual deceleration, you can set each acceleration and deceleration time separately.

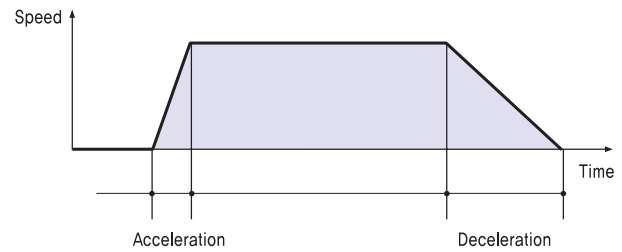

3. Pause

You can pause the motion upon the input of an external signal. When Pause signal change to OFF, the motor will restart to original target position.

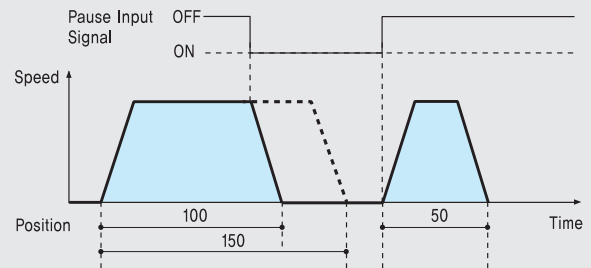

4. Alarm

The number of LED flashing time and information displayed on the 7-Segment indicates which Alarm has occurred.

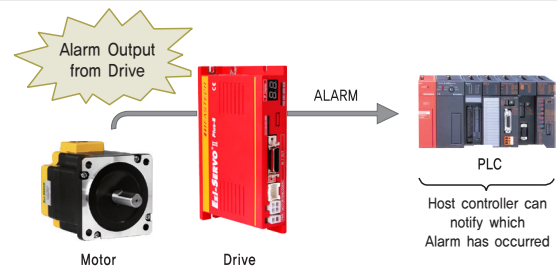

5. Teaching

Teaching signal is used to memorize current Position data into the selected Position Table item.

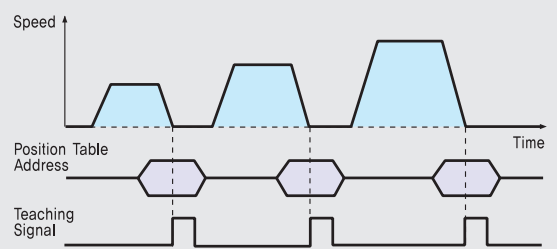

6. Jump

Within one Position Table, you can select various Position Table numbers that you want to jump. With three external input signal during movement, the next jump Position Table number can be select.

◆ Position Table #14	Position	---	Next	---	Input 1	Input 2	Input 3	---
	10000		100		115	116	117	

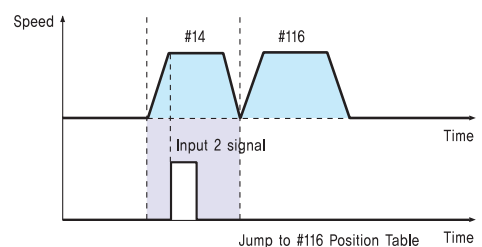
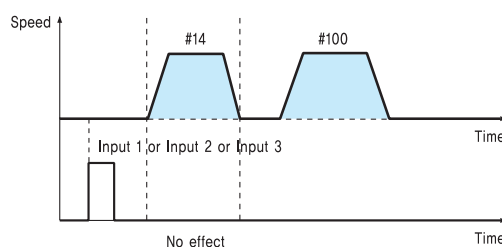

● Ezi-SERVO II Plus-E Part Numbering

Ezi-SERVO II -PE-42S-A-BK-PN10-□

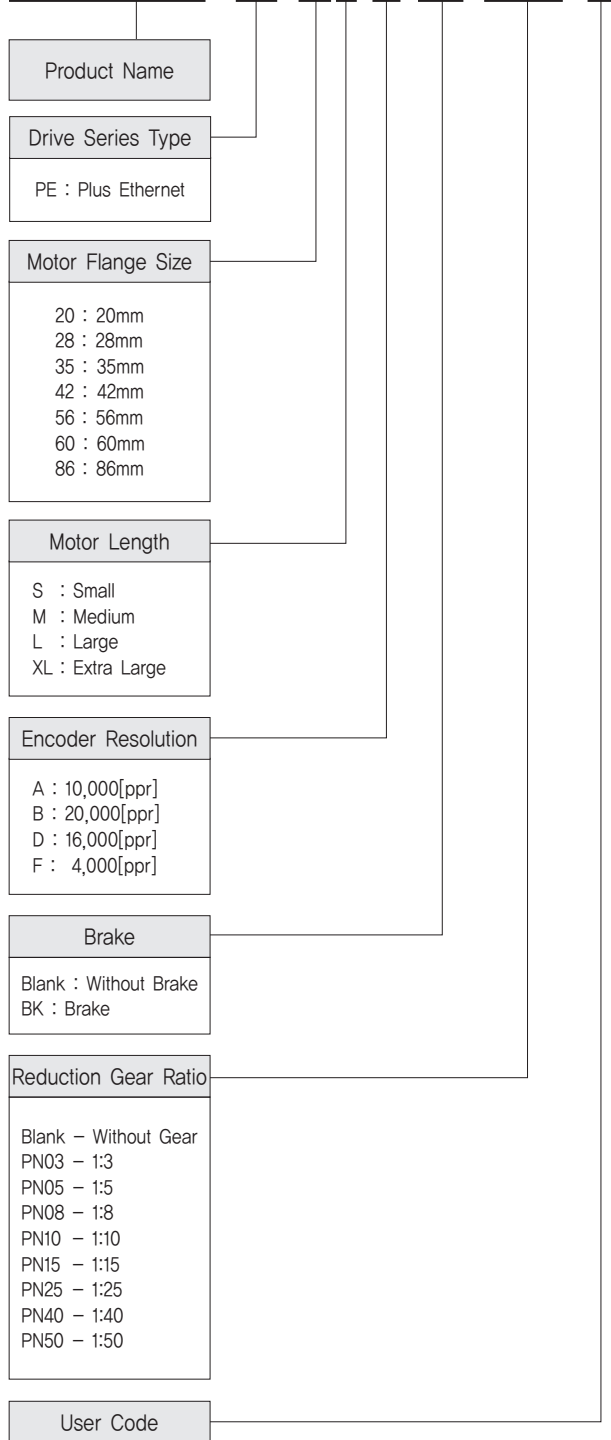

● Standard Combination

Unit Part Number	Motor Model Number	Drive Model Number
Ezi-SERVO II -PE-20M-F	EzM2-20M-F	EzS2-PE-20M-F
Ezi-SERVO II -PE-20L-F	EzM2-20L-F	EzS2-PE-20L-F
Ezi-SERVO II -PE-28S-D	EzM2-28S-D	EzS2-PE-28S-D
Ezi-SERVO II -PE-28SM-D	EzM2-28SM-D	EzS2-PE-28S-D
Ezi-SERVO II -PE-28M-D	EzM2-28M-D	EzS2-PE-28M-D
Ezi-SERVO II -PE-28MM-D	EzM2-28MM-D	EzS2-PE-28M-D
Ezi-SERVO II -PE-28L-D	EzM2-28L-D	EzS2-PE-28L-D
Ezi-SERVO II -PE-28LM-D	EzM2-28LM-D	EzS2-PE-28L-D
Ezi-SERVO II -PE-35M-D	EzM2-35M-D	EzS2-PE-35M-D
Ezi-SERVO II -PE-35MM-D	EzM2-35MM-D	EzS2-PE-35M-D
Ezi-SERVO II -PE-35L-D	EzM2-35L-D	EzS2-PE-35L-D
Ezi-SERVO II -PE-35LM-D	EzM2-35LM-D	EzS2-PE-35L-D
Ezi-SERVO II -PE-42S-A	EzM2-42S-A	EzS2-PE-42S-A
Ezi-SERVO II -PE-42S-B	EzM2-42S-B	EzS2-PE-42S-B
Ezi-SERVO II -PE-42M-A	EzM2-42M-A	EzS2-PE-42M-A
Ezi-SERVO II -PE-42M-B	EzM2-42M-B	EzS2-PE-42M-B
Ezi-SERVO II -PE-42L-A	EzM2-42L-A	EzS2-PE-42L-A
Ezi-SERVO II -PE-42L-B	EzM2-42L-B	EzS2-PE-42L-B
Ezi-SERVO II -PE-42XL-A	EzM2-42XL-A	EzS2-PE-42XL-A
Ezi-SERVO II -PE-42XL-B	EzM2-42XL-B	EzS2-PE-42XL-B
Ezi-SERVO II -PE-56S-A	EzM2-56S-A	EzS2-PE-56S-A
Ezi-SERVO II -PE-56S-B	EzM2-56S-B	EzS2-PE-56S-B
Ezi-SERVO II -PE-56M-A	EzM2-56M-A	EzS2-PE-56M-A
Ezi-SERVO II -PE-56M-B	EzM2-56M-B	EzS2-PE-56M-B
Ezi-SERVO II -PE-56L-A	EzM2-56L-A	EzS2-PE-56L-A
Ezi-SERVO II -PE-56L-B	EzM2-56L-B	EzS2-PE-56L-B
Ezi-SERVO II -PE-60S-A	EzM2-60S-A	EzS2-PE-60S-A
Ezi-SERVO II -PE-60S-B	EzM2-60S-B	EzS2-PE-60S-B
Ezi-SERVO II -PE-60M-A	EzM2-60M-A	EzS2-PE-60M-A
Ezi-SERVO II -PE-60M-B	EzM2-60M-B	EzS2-PE-60M-B
Ezi-SERVO II -PE-60L-A	EzM2-60L-A	EzS2-PE-60L-A
Ezi-SERVO II -PE-60L-B	EzM2-60L-B	EzS2-PE-60L-B
Ezi-SERVO II -PE-86M-A	EzM2-86M-A	EzS2-PE-86M-A
Ezi-SERVO II -PE-86M-B	EzM2-86M-B	EzS2-PE-86M-B
Ezi-SERVO II -PE-86L-A	EzM2-86L-A	EzS2-PE-86L-A
Ezi-SERVO II -PE-86L-B	EzM2-86L-B	EzS2-PE-86L-B
Ezi-SERVO II -PE-86XL-A	EzM2-86XL-A	EzS2-PE-86XL-A
Ezi-SERVO II -PE-86XL-B	EzM2-86XL-B	EzS2-PE-86XL-B

* When places an order for Stopper type 28mm, 35mm motor, please write "M" additionally after motor length of unit part number.
(Ex : Ezi-SERVO II -PE-28LM-D, Ezi-SERVO II -PE-35LM-D)

● Specifications of Drive

Motor Model	EzM2-20 series	EzM2-28 series	EzM2-35 series	EzM2-42 series	EzM2-56 series	EzM2-60 series	EzM2-86 series	
Driver Model	EzS2-PE-20 series	EzS2-PE-28 series	EzS2-PE-35 series	EzS2-PE-42 series	EzS2-PE-56 series	EzS2-PE-60 series	EzS2-PE-86 series	
Input Voltage	24VDC \pm 10%						40~70VDC	
Control Method	Closed loop control with 32bit MCU							
Multi Axes Drive	Maximum 254 axis operating (Selectable IP: 1~254)							
Position Table	256 motion command steps (Speed, External start, Jump, Loop, Wait and PT finish etc.)							
Current Consumption	Max 500mA (Except motor current)							
Operating Condition	Ambient Temperature	<ul style="list-style-type: none"> In Use: 0~50°C In Storage: -20~70°C 						
	Humidity	<ul style="list-style-type: none"> In Use: 35~85% RH (Non-Condensing) In Storage: 10~90% RH (Non-Condensing) 						
	Vib. Resist.	0,5g						
Function	Rotation Speed	0~3,000 [rpm] *1						
	Resolution [ppr]	4,000/Rev, Encoder model: 500 1,000 1,600 2,000 3,600 5,000 6,400 7,200 10,000 4,000 10,000/Rev, Encoder model: 500 1,000 1,600 2,000 3,600 5,000 6,400 7,200 10,000 16,000/Rev, Encoder model: 500 1,000 1,600 2,000 3,600 5,000 6,400 7,200 10,000 16,000 20,000/Rev, Encoder model: 500 1,000 1,600 2,000 3,600 5,000 6,400 7,200 10,000 20,000 (Selectable by parameter) *2						
	Protection Functions	Over Current Error, Over Speed Error, Position Tracking Error, Over Load Error, Over Temperature Error, Over Regenerated Voltage Error, Motor Connect Error, Encoder Connect Error, Motor Voltage Error, In-Position Error, ROM Error, Position Overflow Error						
	LED Display	Power status, In-Position status, Servo On status, Alarm status						
	In-Position Selection	0~63 (Selectable by parameter)						
	Position Gain Selection	0~63 (Selectable by parameter)						
	Rotational Direction	CW/CCW (Selectable by parameter)						
	I/O Signal	Input Signals	3 dedicated inputs (LIMIT+, LIMIT-, ORIGIN), 9 programmable inputs (Photocoupler)					
Output Signals		1 dedicated output (Compare Out), 9 programmable outputs (Photocoupler), Brake						
Communication Interface	Ethernet communication, Dual port Ethernet switch embeded, Communication speed: 10/100 Base - T/TX Full-Duplex							
Position Control	<ul style="list-style-type: none"> Incremental mode / Absolute mode Data Range: -134,217,728 to +134,217,727 [pulse] Operating speed: Max. 3,000 [rpm] 							
Return to Origin	Origin Sensor, Z phase, \pm Limit sensor, Torque							
GUI	User Interface Program within Windows							
Library	Motion Library (DLL) for windows XP/7/8/10							

*1 : Up to the resolution of 10,000[ppr], maximum speed can be reached by 3,000[rpm] and with the resolution more than 10,000[ppr], maximum speed shall be reduced accordingly.

*2 : When selected resolution is more than encoder resolution, motor shall be operated by microstep between pulses.

● Dimensions of Drive [mm]

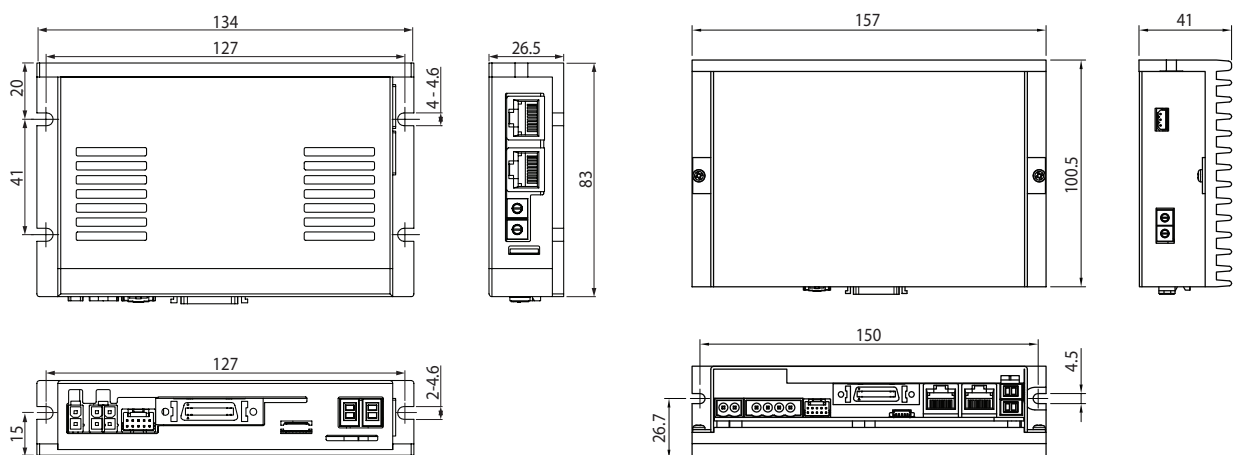

※ 86mm motor drive (EzS2-PE-86 series)

● Specifications of Motor

MODEL	UNIT	EzM2-20 series		EzM2-28 series			EzM2-35 series		EzM2-42 series			
		20M	20L	28S	28M	28L	35M	35L	42S	42M	42L	42XL
DRIVE METHOD	-	BI-POLAR										
NUMBER OF PHASES	-	2	2	2	2	2	2	2	2	2	2	2
VOLTAGE	VDC	2,75	3,0	3,0	3,0	3,0	2,88	4,59	3,36	4,32	4,56	7,2
CURRENT per PHASE	A	0,5	0,5	0,95	0,95	0,95	0,6	0,85	1,2	1,2	1,2	1,2
RESISTANCE per PHASE	Ohm	5,5	6,0	3,2	3,2	3,2	4,8	5,4	2,8	3,6	3,8	6,0
INDUCTANCE per PHASE	mH	2,0	2,6	2,0	2,7	3,2	6,1	6,5	5,4	7,2	8,0	15,6
HOLDING TORQUE	N·m	0,016	0,025	0,069	0,098	0,118	0,05	0,176	0,32	0,44	0,5	0,65
ROTOR INERTIA	g·cm ²	2,5	3,3	9,0	13	18	8	11	35	54	77	114
WEIGHTS	g	50	80	110	140	200	120	200	250	280	350	500
LENGTH(L)	mm	28	38	32	45	50	26	38	34	40	48	60
PERMISSIBLE OVERHUNG LOAD (DISTANCE FROM END OF SHAFT)	3mm	N	18	18	30	30	30	22	22	22	22	22
	8mm		30	30	38	38	38	26	26	26	26	26
	13mm		-	-	53	53	53	33	33	33	33	33
	18mm		-	-	-	-	-	46	46	46	46	46
PERMISSIBLE THRUST LOAD	N	Lower than motor weight										
INSULATION RESISTANCE	Mohm	100 MIN.(at 500VDC)										
INSULATION CLASS	-	CLASS B(130°C)										
OPERATING TEMPERATURE	°C	0 to 55										

MODEL	UNIT	EzM2-56 series			EzM2-60 series			EzM2-86 series			
		56S	56M	56L	60S	60M	60L	86M	86L	86XL	
DRIVE METHOD	-	BI-POLAR									
NUMBER OF PHASES	-	2	2	2	2	2	2	2	2	2	
VOLTAGE	VDC	1,56	1,62	2,64	1,32	1,48	2,2	2,34	3,6	4,8	
CURRENT per PHASE	A	3,0	3,0	3,0	4,0	4,0	4,0	6,0	6,0	6,0	
RESISTANCE per PHASE	Ohm	0,52	0,54	0,88	0,33	0,37	0,55	0,39	0,6	0,8	
INDUCTANCE per PHASE	mH	1,2	2,0	4,0	0,75	1,1	2,7	3,0	6,5	8,68	
HOLDING TORQUE	N·m	0,64	1,0	1,5	0,88	1,28	2,4	4,5	8,5	12	
ROTOR INERTIA	g·cm ²	180	280	520	240	490	690	1800	3600	5400	
WEIGHTS	g	500	720	1150	600	1000	1300	2300	3800	5300	
LENGTH(L)	mm	46	55	80	47	56	85	78	117	155	
PERMISSIBLE OVERHUNG LOAD (DISTANCE FROM END OF SHAFT)	3mm	N	52	52	52	70	70	70	270	270	270
	8mm		65	65	65	87	87	87	300	300	300
	13mm		85	85	85	114	114	114	350	350	350
	18mm		123	123	123	165	165	165	400	400	400
PERMISSIBLE THRUST LOAD	N	Lower than motor weight									
INSULATION RESISTANCE	Mohm	100 MIN.(at 500VDC)									
INSULATION CLASS	-	CLASS B(130°C)									
OPERATING TEMPERATURE	°C	0 to 55									

Torque Characteristics of Motor

Ezi-SERVOII-PE-20 series

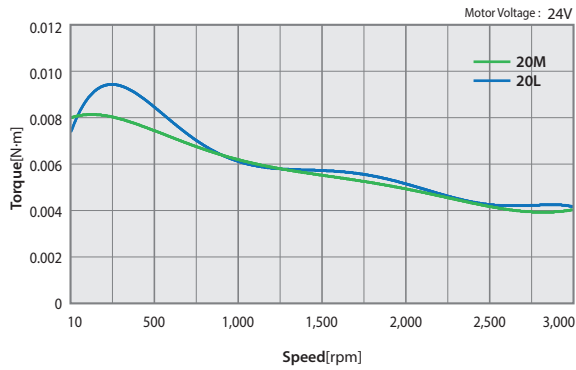

Ezi-SERVOII-PE-28 series

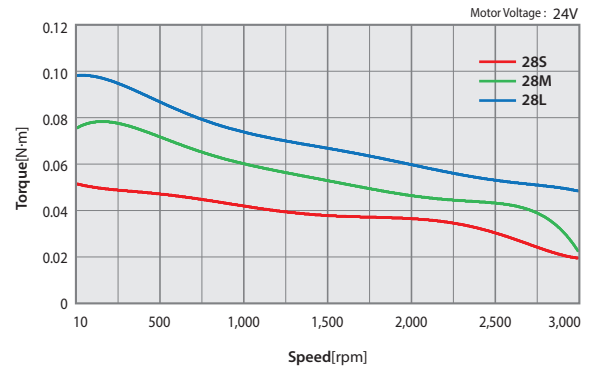

Ezi-SERVOII-PE-35 series

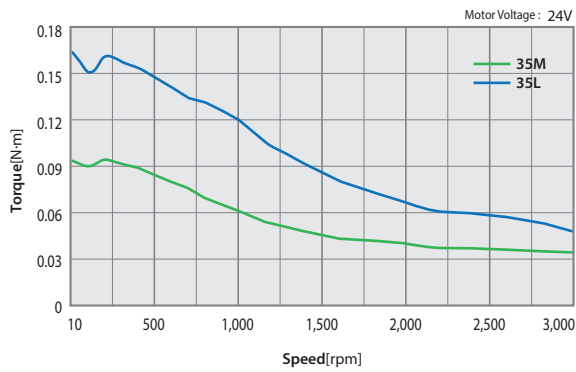

Ezi-SERVOII-PE-42 series

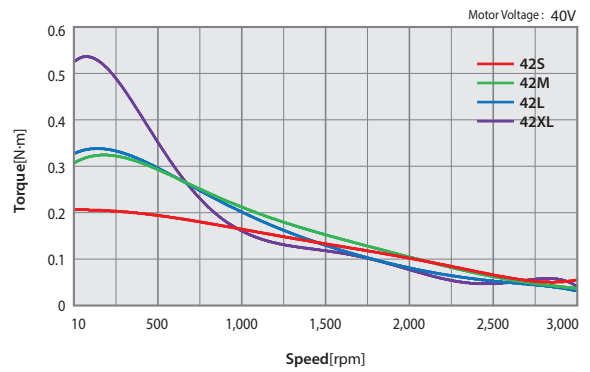

Ezi-SERVOII-PE-56 series

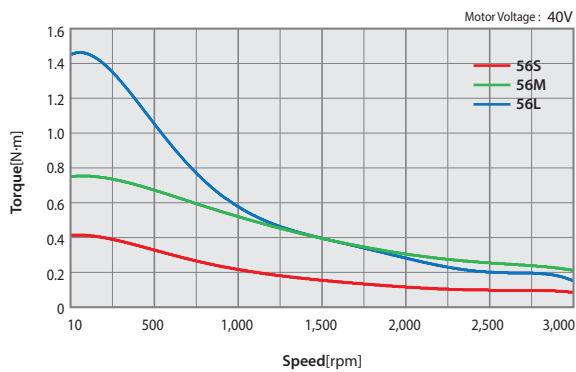

Ezi-SERVOII-PE-60 series

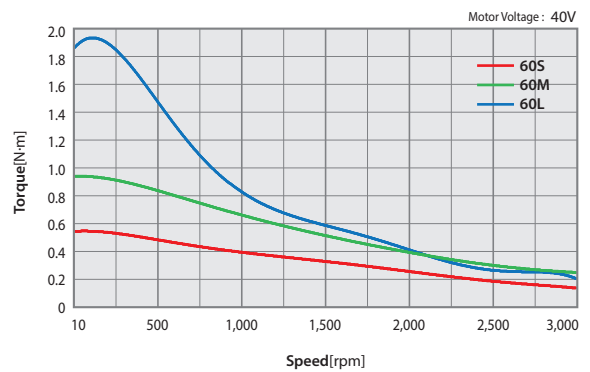

Ezi-SERVOII-PE-86 series

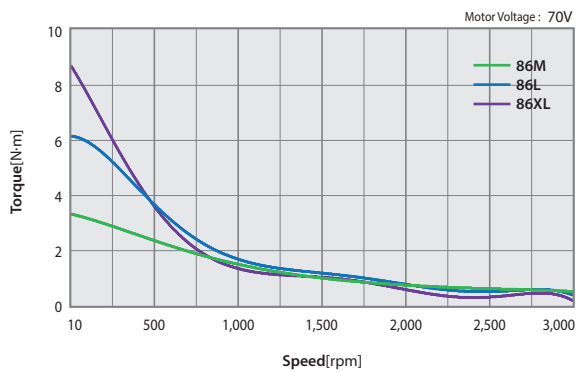

● Dimensions of Motor [mm]

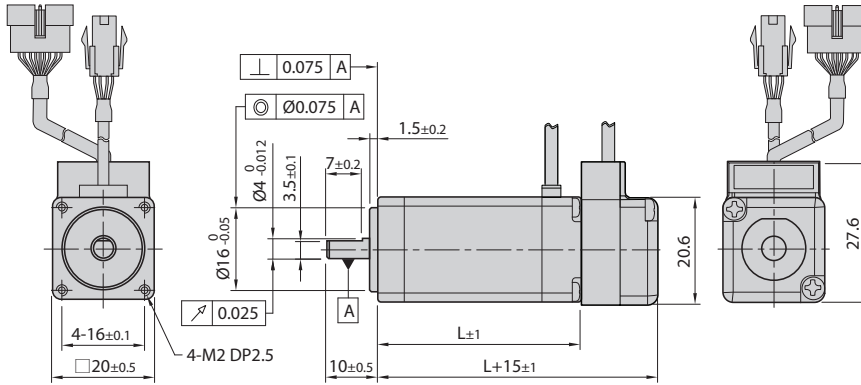

20mm

Model name	Length(L)
EzM2-20M	28
EzM2-20L	38

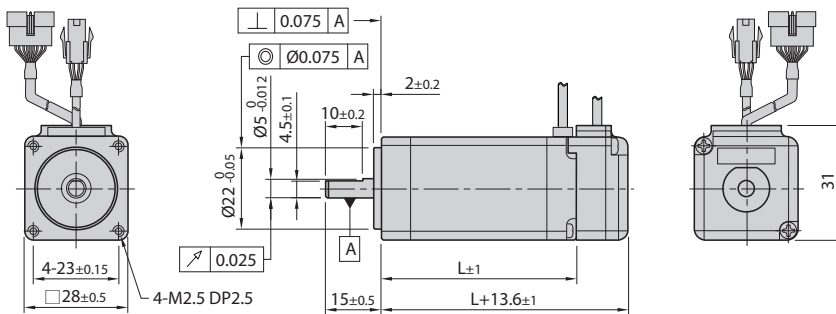

28mm

Model name	Length(L)
EzM2-28S	32
EzM2-28M	45
EzM2-28L	50

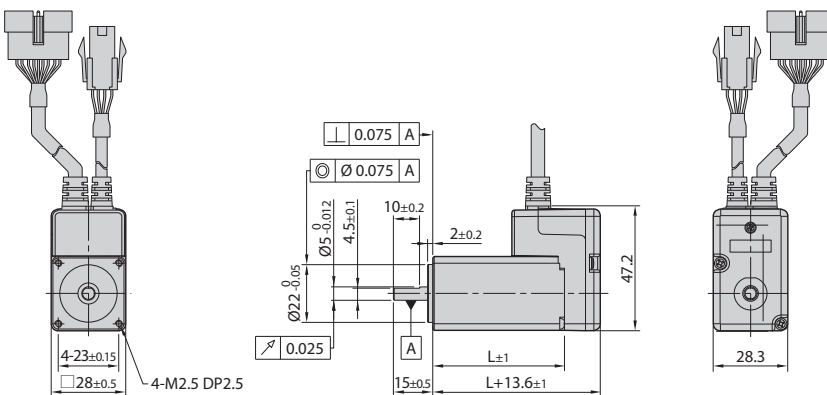

28mm (Stopper type)

Model name	Length(L)
EzM2-28SM	32
EzM2-28MM	45
EzM2-28LM	50

※ When ordering 28mm Stopper type of motor, please add "M" after standard motor model number.

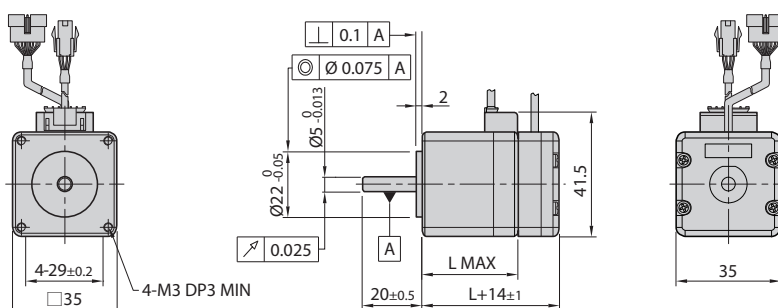

35mm

Model name	Length(L)
EzM2-35M	32
EzM2-35L	36

● Dimensions of Motor [mm]

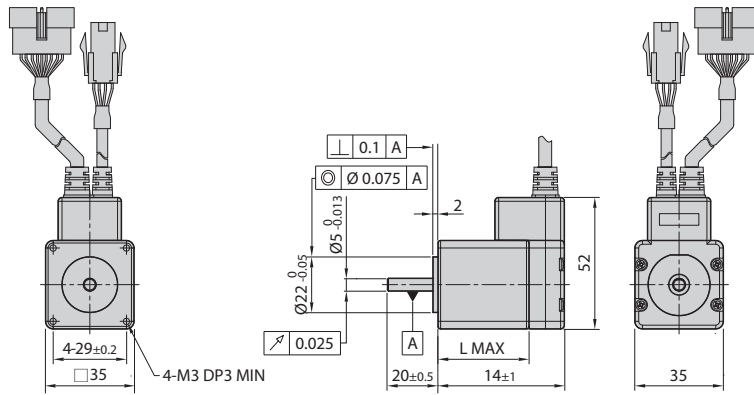

35mm (Stopper type)

Model name	Length(L)
EzM2-35MM	32
EzM2-35LM	36

※ When ordering 35mm Stopper type of motor, please add "M" after standard motor model number.

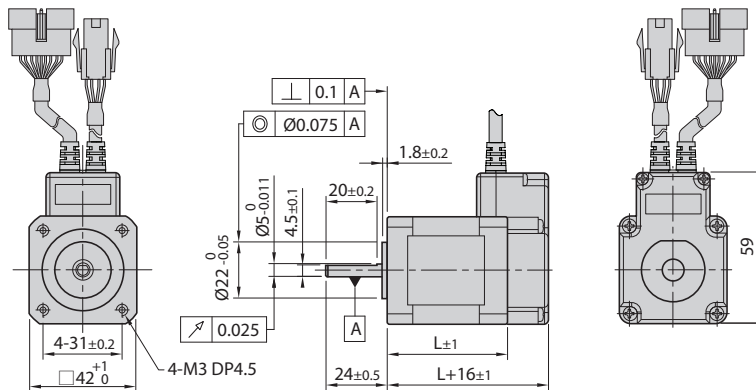

42mm

Model name	Length(L)
EzM2-42S	34
EzM2-42M	40
EzM2-42L	48
EzM2-42XL	60

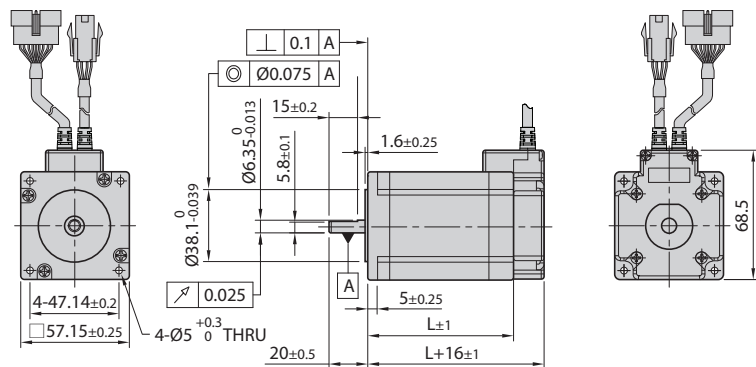

56mm

Model name	Length(L)
EzM2-56S	46
EzM2-56M	55
EzM2-56L	80

※ There are 2 kinds size of front shaft diameter for EzM2-56 series as Ø6.35 and Ø8.0.

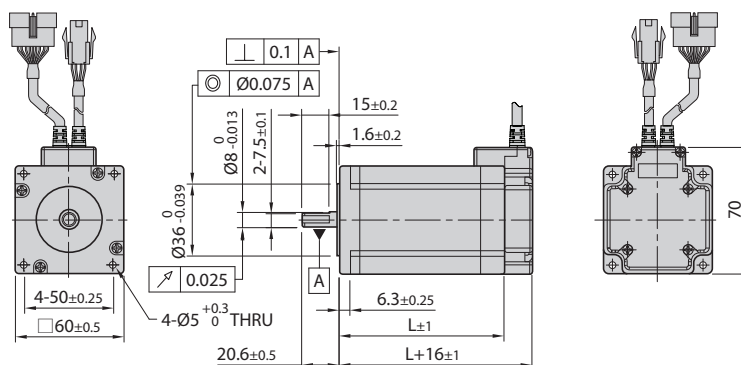

60mm

Model name	Length(L)
EzM2-60S	47
EzM2-60M	56
EzM2-60L	85

● Dimensions of Motor [mm]

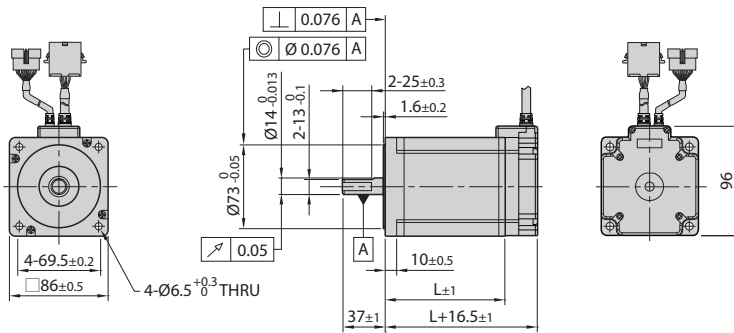

86mm

모터 품명	길이(L)
EzM2-86M	78
EzM2-86L	117
EzM2-86XL	155

● Specifications of Motor with Brake

Unit Part Number	Motor Model Number	Electronic Brake					Motor Unit Weight [g]	Permitted Overhung Load [N]				Permitted Thrust Load [N]
		Type	Voltage Input [V]	Rated Current [A]	Power Consumption [W]	Statical Friction Torque [N·m]		Length from Motor Point [mm]				
								3	8	13	18	
Ezi-SERVO II -PE-42S-■-BK	EzM2-42S-■-BK	Non-excitation run Type	24VDC ±10%	0.2	5	0.2	510	22	26	33	46	Must be Lower than Unit's Weight
Ezi-SERVO II -PE-42M-■-BK	EzM2-42M-■-BK						570					
Ezi-SERVO II -PE-42L-■-BK	EzM2-42L-■-BK						640					
Ezi-SERVO II -PE-42XL-■-BK	EzM2-42XL-■-BK						770					
Ezi-SERVO II -PE-56S-■-BK	EzM2-56S-■-BK			0.27	6.6	0.7	1030	52	65	85	123	
Ezi-SERVO II -PE-56M-■-BK	EzM2-56M-■-BK						1190					
Ezi-SERVO II -PE-56L-■-BK	EzM2-56L-■-BK						1630					
Ezi-SERVO II -PE-60S-■-BK	EzM2-60S-■-BK						1150					
Ezi-SERVO II -PE-60M-■-BK	EzM2-60M-■-BK			0.54	13	4	1350	70	87	114	165	
Ezi-SERVO II -PE-60L-■-BK	EzM2-60L-■-BK						1960					
Ezi-SERVO II -PE-86M-■-BK	EzM2-86M-■-BK						3600					
Ezi-SERVO II -PE-86L-■-BK	EzM2-86L-■-BK						5100					
Ezi-SERVO II -PE-86XL-■-BK	EzM2-86XL-■-BK	6600	270	300	350	400						

- * The code of encoder resolution will be marked in "■"
- * Electronic Brake cannot be used for braking. Position hold purpose only when power OFF.
- * The weight means Motor Unit Weight including Motor and Electronic Brake.
- * Motor Model Number is combined model name of Motor and Brake.
- * Motor specification and torque characteristic are same as Standard Motor.
- * An external power supply (24VDC) is not required when installing the Electric Brake on the 86mm motor drive.

* Brake Operation Timing Chart

Ezi-SERVO II Plus-E controls Brake by Drive automatically. Please refer to below Timing Chart when Brake is controlled by the upper controller other than using Ezi-SERVO II Plus-E Brake control. Otherwise, Drive malfunctioning and loads can be fall down. Also, please do not operate Brake while motor operation to prevent damage.

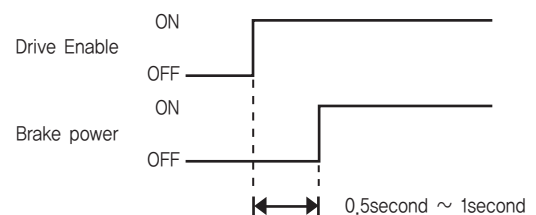

● Dimensions of Motor with Brake [mm]

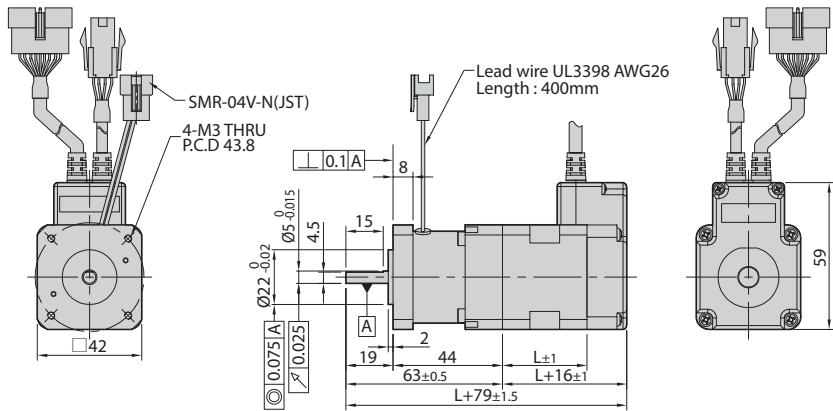

42mm

Model Name	Length(L)	Weight(kg)
EzM2-42S	34	0,51
EzM2-42M	40	0,57
EzM2-42L	48	0,64
EzM2-42XL	60	0,77

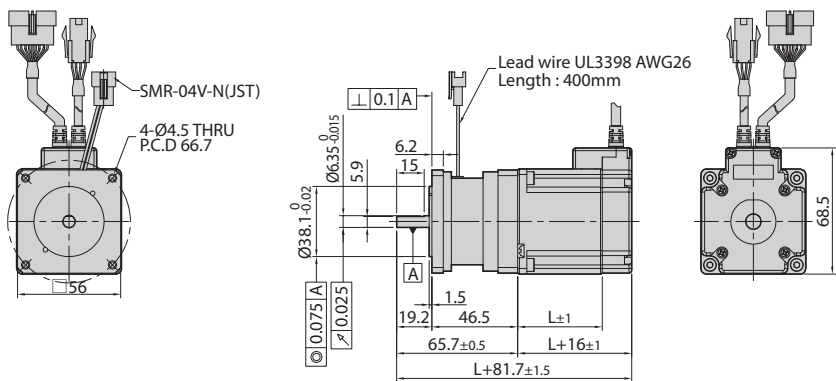

56mm

Model Name	Length(L)	Weight(kg)
EzM2-56S	46	1,03
EzM2-56M	55	1,19
EzM2-56L	80	1,63

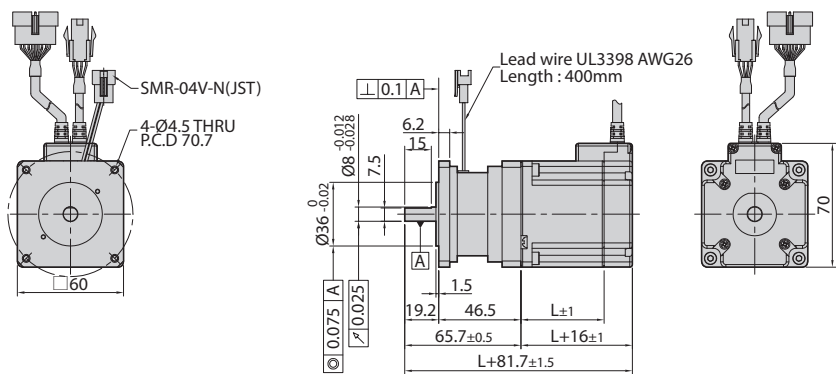

60mm

Model Name	Length(L)	Weight(kg)
EzM2-60S	47	1,15
EzM2-60M	56	1,35
EzM2-60L	85	1,96

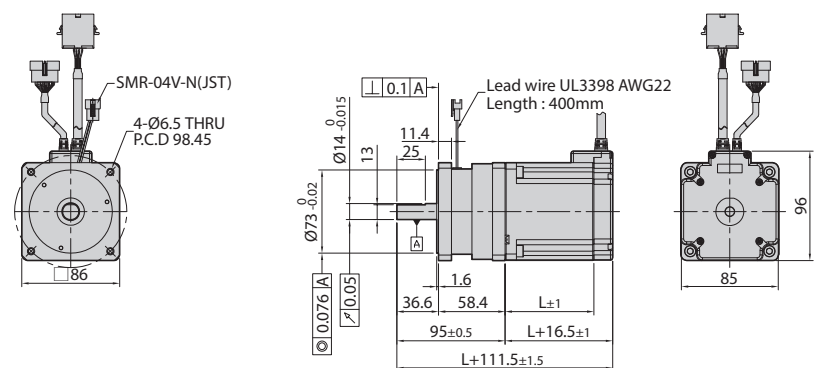

86mm

Model Name	Length(L)	Weight(kg)
EzM2-86M	78	3,6
EzM2-86L	117	5,1
EzM2-86XL	155	6,6

● Specifications of Motor with Gearbox

42_{mm}

Unit Part Number	Maximum Holding Torque [N·m]	Rotor Inertia Moment [kg·m ²]	Back-lash [min]	Angle Transmission Error [min]	Re-duction Gear Ratio	Resolution (10,000 [ppr] Standard)	Permitted Torque [N·m]	Maximum Torque [N·m]	Permitted Speed Range [rpm]	Unit Weight [kg]	Permitted Overhung Load [N]	Permitted Thrust Load [N]
											Axis Center Standard	
Ezi-SERVO II -PE-42S-■-PN3	0,57	35x10 ⁻⁷	3	5	3	0,012°	6	12	0~1000	0,89	240	270
Ezi-SERVO II -PE-42S-■-PN5	0,95				5	0,0072°	9	18	0~600		290	330
Ezi-SERVO II -PE-42S-■-PN8	1,52				8	0,0045°	9	18	0~375		340	410
Ezi-SERVO II -PE-42S-■-PN10	1,90				10	0,0036°	6	12	0~300		360	450
Ezi-SERVO II -PE-42S-■-PN15	2,76		5	7	15	0,0024°	6	12	0~200	0,99	410	540
Ezi-SERVO II -PE-42S-■-PN25	4,60				25	0,00144°	9	18	0~120		490	640
Ezi-SERVO II -PE-42S-■-PN40	7,36				40	0,0009°	9	18	0~75		570	640
Ezi-SERVO II -PE-42S-■-PN50	9,00				50	0,00072°	9	18	0~60		620	640
Ezi-SERVO II -PE-42M-■-PN3	0,85	54x10 ⁻⁷	3	5	3	0,012°	6	12	0~1000	0,96	240	270
Ezi-SERVO II -PE-42M-■-PN5	1,42				5	0,0072°	9	18	0~600		290	330
Ezi-SERVO II -PE-42M-■-PN8	2,28				8	0,0045°	9	18	0~375		340	410
Ezi-SERVO II -PE-42M-■-PN10	2,85				10	0,0036°	6	12	0~300		360	450
Ezi-SERVO II -PE-42M-■-PN15	4,14		5	7	15	0,0024°	6	12	0~200	1,06	410	540
Ezi-SERVO II -PE-42M-■-PN25	6,90				25	0,00144°	9	18	0~120		490	640
Ezi-SERVO II -PE-42M-■-PN40	9,00				40	0,0009°	9	18	0~75		570	640
Ezi-SERVO II -PE-42M-■-PN50	9,00				50	0,00072°	9	18	0~60		620	640
Ezi-SERVO II -PE-42L-■-PN3	0,92	77x10 ⁻⁷	3	5	3	0,012°	6	12	0~1000	1,02	240	270
Ezi-SERVO II -PE-42L-■-PN5	1,54				5	0,0072°	9	18	0~600		290	330
Ezi-SERVO II -PE-42L-■-PN8	2,47				8	0,0045°	9	18	0~375		340	410
Ezi-SERVO II -PE-42L-■-PN10	3,09				10	0,0036°	6	12	0~300		360	450
Ezi-SERVO II -PE-42L-■-PN15	4,49		5	7	15	0,0024°	6	12	0~200	1,12	410	540
Ezi-SERVO II -PE-42L-■-PN25	7,49				25	0,00144°	9	18	0~120		490	640
Ezi-SERVO II -PE-42L-■-PN40	9,00				40	0,0009°	9	18	0~75		570	640
Ezi-SERVO II -PE-42L-■-PN50	9,00				50	0,00072°	9	18	0~60		620	640
Ezi-SERVO II -PE-42XL-■-PN3	1,45	114x10 ⁻⁷	3	5	3	0,012°	6	12	0~1000	1,15	240	270
Ezi-SERVO II -PE-42XL-■-PN5	2,42				5	0,0072°	9	18	0~600		290	330
Ezi-SERVO II -PE-42XL-■-PN8	3,87				8	0,0045°	9	18	0~375		340	410
Ezi-SERVO II -PE-42XL-■-PN10	4,84				10	0,0036°	6	12	0~300		360	450
Ezi-SERVO II -PE-42XL-■-PN15	6,00		5	7	15	0,0024°	6	12	0~200	1,25	410	540
Ezi-SERVO II -PE-42XL-■-PN25	9,00				25	0,00144°	9	18	0~120		490	640
Ezi-SERVO II -PE-42XL-■-PN40	9,00				40	0,0009°	9	18	0~75		570	640
Ezi-SERVO II -PE-42XL-■-PN50	9,00				50	0,00072°	9	18	0~60		620	640

* The code of encoder resolution will be marked in "■"

● Specifications of Motor with Gearbox

56_{mm}

Unit Part Number	Maximum Holding Torque [N·m]	Rotor Inertia Moment [kg·m ²]	Back-lash [min]	Angle Transmission Error [min]	Reduction Gear Ratio	Resolution (10,000 [ppr] Standard)	Permitted Torque [N·m]	Maximum Torque [N·m]	Permitted Speed Range [rpm]	Unit Weight [kg]	Permitted Overhung Load [N]	Permitted Thrust Load [N]
											Axis Center Standard	
Ezi-SERVO II -PE-56S-■-PN3	1,1	180x10 ⁻⁷	3	5	3	0,012°	18	35	0~1000	1,94	430	310
Ezi-SERVO II -PE-56S-■-PN5	1,9										510	390
Ezi-SERVO II -PE-56S-■-PN8	3,0										600	480
Ezi-SERVO II -PE-56S-■-PN10	3,8										640	530
Ezi-SERVO II -PE-56S-■-PN15	5,5									2,14	740	630
Ezi-SERVO II -PE-56S-■-PN25	9,3										870	790
Ezi-SERVO II -PE-56S-■-PN40	14,9										1000	970
Ezi-SERVO II -PE-56S-■-PN50	18,6										1100	1100
Ezi-SERVO II -PE-56M-■-PN3	2,0	280x10 ⁻⁷	3	5	3	0,012°	18	35	0~1000	2,15	430	310
Ezi-SERVO II -PE-56M-■-PN5	3,4										510	390
Ezi-SERVO II -PE-56M-■-PN8	5,4										600	480
Ezi-SERVO II -PE-56M-■-PN10	6,8										640	530
Ezi-SERVO II -PE-56M-■-PN15	9,9									2,35	740	630
Ezi-SERVO II -PE-56M-■-PN25	16,6										870	790
Ezi-SERVO II -PE-56M-■-PN40	27,0										1000	970
Ezi-SERVO II -PE-56M-■-PN50	27,0										1100	1100
Ezi-SERVO II -PE-56L-■-PN3	4,0	520x10 ⁻⁷	3	5	3	0,012°	18	35	0~1000	2,52	430	310
Ezi-SERVO II -PE-56L-■-PN5	6,8										510	390
Ezi-SERVO II -PE-56L-■-PN8	10,8										600	480
Ezi-SERVO II -PE-56L-■-PN10	13,6										640	530
Ezi-SERVO II -PE-56L-■-PN15	18,0									2,72	740	630
Ezi-SERVO II -PE-56L-■-PN25	27,0										870	790
Ezi-SERVO II -PE-56L-■-PN40	27,0										1000	970
Ezi-SERVO II -PE-56L-■-PN50	27,0										1100	1100

* The code of encoder resolution will be marked in "■"

● Specifications of Motor with Gearbox

60_{mm}

Unit Part Number	Maximum Holding Torque [N·m]	Rotor Inertia Moment [kg·m ²]	Back-lash [min]	Angle Transmission Error [min]	Re-duction Gear Ratio	Resolution (10,000 [ppr] Standard)	Permitted Torque [N·m]	Maximum Torque [N·m]	Permitted Speed Range [rpm]	Unit Weight [kg]	Permitted Overhung Load [N]	Permitted Thrust Load [N]	
											Axis Center Standard		
Ezi-SERVO II -PE-60S-■-PN3	1,5	240x10 ⁻⁷	3	5	3	0,012°	18	35	0~1000	2,0	430	310	
Ezi-SERVO II -PE-60S-■-PN5	2,5										510	390	
Ezi-SERVO II -PE-60S-■-PN8	4,0										600	480	
Ezi-SERVO II -PE-60S-■-PN10	5,1										640	530	
Ezi-SERVO II -PE-60S-■-PN15	7,4										2,2	740	630
Ezi-SERVO II -PE-60S-■-PN25	12,3											870	790
Ezi-SERVO II -PE-60S-■-PN40	19,8											1000	970
Ezi-SERVO II -PE-60S-■-PN50	24,7											1100	1100
Ezi-SERVO II -PE-60M-■-PN3	2,6	490x10 ⁻⁷	3	5	3	0,012°	18	35	0~1000	2,0	430	310	
Ezi-SERVO II -PE-60M-■-PN5	4,4										510	390	
Ezi-SERVO II -PE-60M-■-PN8	7,0										600	480	
Ezi-SERVO II -PE-60M-■-PN10	8,8										640	530	
Ezi-SERVO II -PE-60M-■-PN15	12,8										2,2	740	630
Ezi-SERVO II -PE-60M-■-PN25	21,4											870	790
Ezi-SERVO II -PE-60M-■-PN40	27,0											1000	970
Ezi-SERVO II -PE-60M-■-PN50	27,0											1100	1100
Ezi-SERVO II -PE-60L-■-PN3	5,2	690x10 ⁻⁷	3	5	3	0,012°	18	35	0~1000	3,0	430	310	
Ezi-SERVO II -PE-60L-■-PN5	8,7										510	390	
Ezi-SERVO II -PE-60L-■-PN8	13,9										600	480	
Ezi-SERVO II -PE-60L-■-PN10	18,0										640	530	
Ezi-SERVO II -PE-60L-■-PN15	18,0										3,2	740	630
Ezi-SERVO II -PE-60L-■-PN25	27,0											870	790
Ezi-SERVO II -PE-60L-■-PN40	27,0											1000	970
Ezi-SERVO II -PE-60L-■-PN50	27,0											1100	1100

* The code of encoder resolution will be marked in "■"

● Specifications of Motor with Gearbox

86mm

Unit Part Number	Maximum Holding Torque [N·m]	Rotor Inertia Moment [kg·m ²]	Back-lash [min]	Angle Transmission Error [min]	Reduction Gear Ratio	Resolution (10,000 [ppr] Standard)	Permitted Torque [N·m]	Maximum Torque [N·m]	Permitted Speed Range [rpm]	Unit Weight [kg]	Permitted Overhung Load [N]	Permitted Thrust Load [N]
											Axis Center Standard	
Ezi-SERVO II -PE-86M-■-PN3	9,6	1800x10 ⁻⁷	3	5	3	0,012°	50	80	0~1000	6,0	810	930
Ezi-SERVO II -PE-86M-■-PN5	16,0										960	1200
Ezi-SERVO II -PE-86M-■-PN8	25,7										1100	1400
Ezi-SERVO II -PE-86M-■-PN10	32,1										1200	1600
Ezi-SERVO II -PE-86M-■-PN15	46,6									6,5	1200	1900
Ezi-SERVO II -PE-86M-■-PN25	75,0										1600	2200
Ezi-SERVO II -PE-86M-■-PN40	75,0										1900	2200
Ezi-SERVO II -PE-86M-■-PN50	75,0										2100	2200
Ezi-SERVO II -PE-86L-■-PN3	17,1	3600x10 ⁻⁷	3	5	3	0,012°	50	80	0~1000	7,5	810	930
Ezi-SERVO II -PE-86L-■-PN5	28,5										960	1200
Ezi-SERVO II -PE-86L-■-PN8	45,6										1100	1400
Ezi-SERVO II -PE-86L-■-PN10	50,0										1200	1600
Ezi-SERVO II -PE-86L-■-PN15	50,0									8,0	1200	1900
Ezi-SERVO II -PE-86L-■-PN25	75,0										1600	2200
Ezi-SERVO II -PE-86L-■-PN40	75,0										1900	2200
Ezi-SERVO II -PE-86L-■-PN50	75,0										2100	2200
Ezi-SERVO II -PE-86XL-■-PN3	23,6	5400x10 ⁻⁷	3	5	3	0,012°	50	80	0~1000	9,0	810	930
Ezi-SERVO II -PE-86XL-■-PN5	39,4										960	1200
Ezi-SERVO II -PE-86XL-■-PN8	63,0										1100	1400
Ezi-SERVO II -PE-86XL-■-PN10	50,0										1200	1600
Ezi-SERVO II -PE-86XL-■-PN15	50,0									9,5	1200	1900
Ezi-SERVO II -PE-86XL-■-PN25	75,0										1600	2200
Ezi-SERVO II -PE-86XL-■-PN40	75,0										1900	2200
Ezi-SERVO II -PE-86XL-■-PN50	75,0										2100	2200

* The code of encoder resolution will be marked in "■"

● Dimensions of Motor with Gearbox [mm]

42mm

Unit Part Number	Motor	Stage	□ Reduction Gear Ratio	L Length [mm]
Ezi-SERVO II-PE-42S-■-PN□	EzM2-42S-■-PN□	Single Stage	3, 5, 8, 10	34
Ezi-SERVO II-PE-42M-■-PN□	EzM2-42M-■-PN□		3, 5, 8, 10	40
Ezi-SERVO II-PE-42L-■-PN□	EzM2-42L-■-PN□		3, 5, 8, 10	48
Ezi-SERVO II-PE-42XL-■-PN□	EzM2-42XL-■-PN□		3, 5, 8, 10	60

* The code of encoder resolution will be marked in "■"

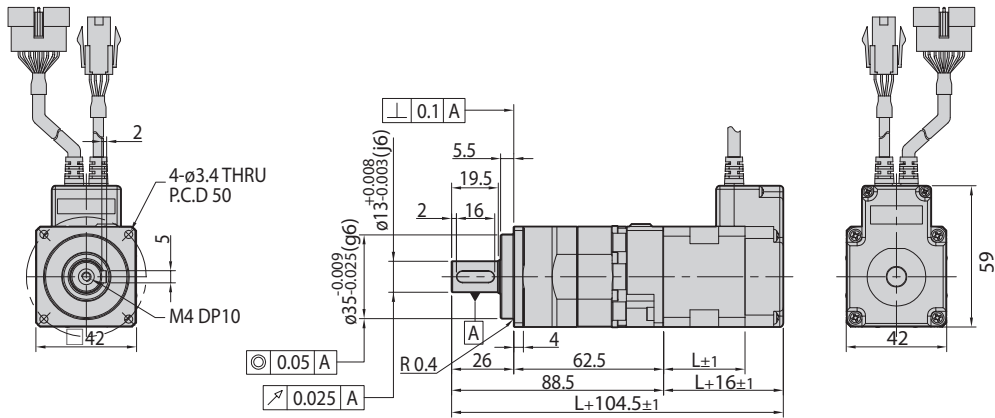

Unit Part Number	Motor	Stage	□ Reduction Gear Ratio	L Length [mm]
Ezi-SERVO II-PE-42S-■-PN□	EzM2-42S-■-PN□	Double Stage	15, 25, 40, 50	34
Ezi-SERVO II-PE-42M-■-PN□	EzM2-42M-■-PN□		15, 25, 40, 50	40
Ezi-SERVO II-PE-42L-■-PN□	EzM2-42L-■-PN□		15, 25, 40, 50	48
Ezi-SERVO II-PE-42XL-■-PN□	EzM2-42XL-■-PN□		15, 25, 40, 50	60

* The code of encoder resolution will be marked in "■"

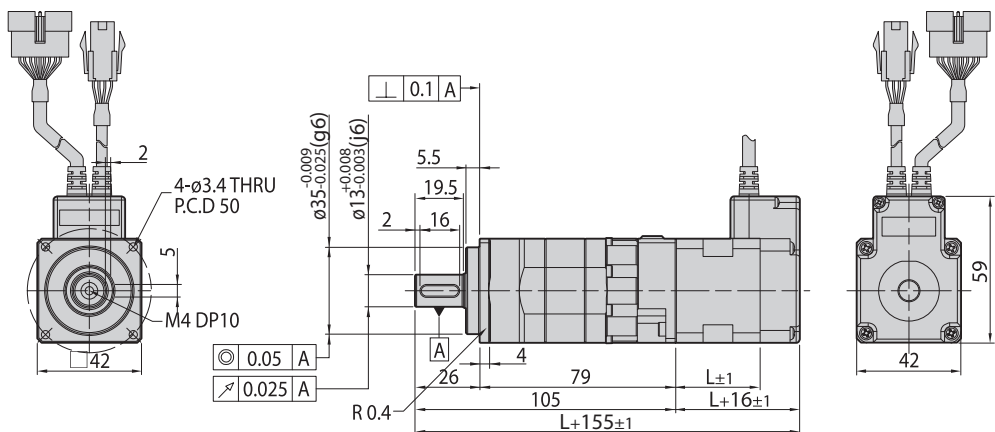

● Dimensions of Motor with Gearbox [mm]

56mm

Unit Part Number	Motor	Stage	□ Reduction Gear Ratio	L Length [mm]
Ezi-SERVO II -PE-56S-■-PN□	EzM2-56S-■-PN□	Single Stage	3, 5, 8, 10	46
Ezi-SERVO II -PE-56M-■-PN□	EzM2-56M-■-PN□		3, 5, 8, 10	55
Ezi-SERVO II -PE-56L-■-PN□	EzM2-56L-■-PN□		3, 5, 8, 10	80

* The code of encoder resolution will be marked in "■"

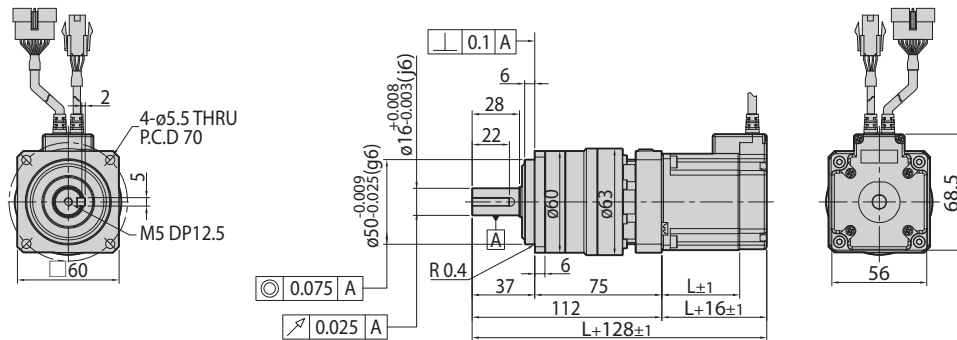

Unit Part Number	Motor	Stage	□ Reduction Gear Ratio	L Length [mm]
Ezi-SERVO II -PE-56S-■-PN□	EzM2-56S-■-PN□	Double Stage	15, 25, 40, 50	46
Ezi-SERVO II -PE-56M-■-PN□	EzM2-56M-■-PN□		15, 25, 40, 50	55
Ezi-SERVO II -PE-56L-■-PN□	EzM2-56L-■-PN□		15, 25, 40, 50	80

* The code of encoder resolution will be marked in "■"

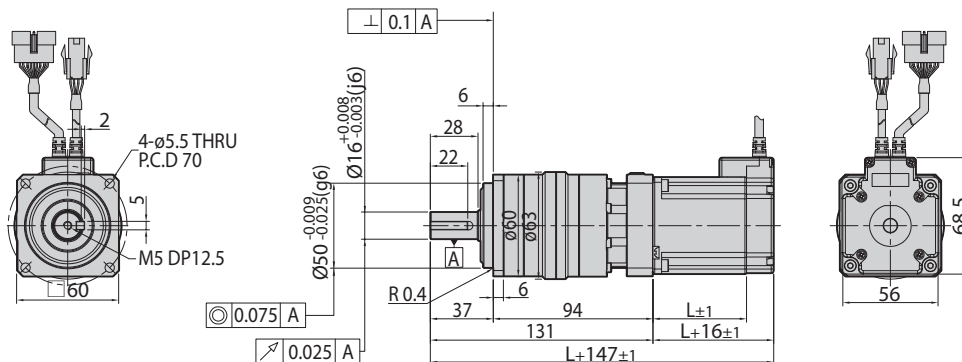

● Dimensions of Motor with Gearbox [mm]

60_{mm}

Unit Part Number	Motor	Stage	□ Reduction Gear Ratio	L Length [mm]
Ezi-SERVO II-PE-60S-■-PN□	EzM2-60S-■-PN□	Single Stage	3, 5, 8, 10	47
Ezi-SERVO II-PE-60M-■-PN□	EzM2-60M-■-PN□		3, 5, 8, 10	56
Ezi-SERVO II-PE-60L-■-PN□	EzM2-60L-■-PN□		3, 5, 8, 10	85

* The code of encoder resolution will be marked in "■"

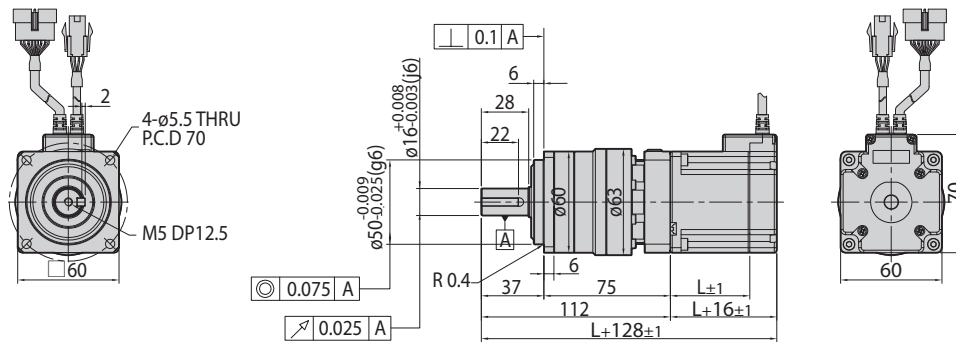

Unit Part Number	Motor	Stage	□ Reduction Gear Ratio	L Length [mm]
Ezi-SERVO II-PE-60S-■-PN□	EzM2-60S-■-PN□	Double Stage	15, 25, 40, 50	47
Ezi-SERVO II-PE-60M-■-PN□	EzM2-60M-■-PN□		15, 25, 40, 50	56
Ezi-SERVO II-PE-60L-■-PN□	EzM2-60L-■-PN□		15, 25, 40, 50	85

* The code of encoder resolution will be marked in "■"

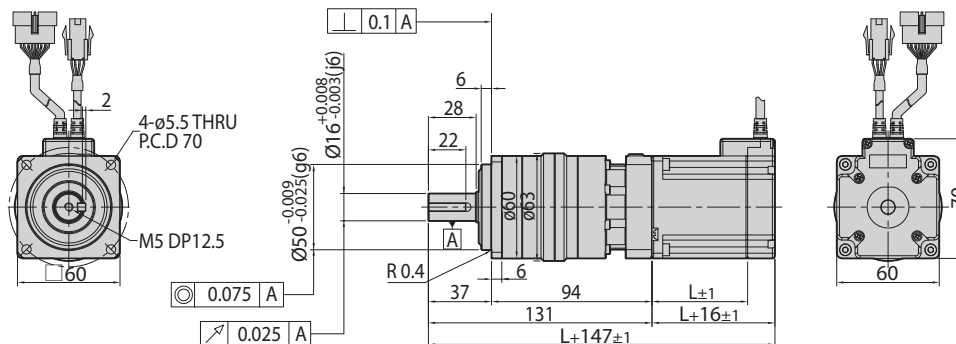

● Dimensions of Motor with Gearbox [mm]

86mm

Unit Part Number	Motor	Stage	□ Reduction Gear Ratio	L Length [mm]
Ezi-SERVO II -PE-86M-■-PN□	EzM2-86M-■-PN□	Single Stage	3, 5, 8, 10	78
Ezi-SERVO II -PE-86L-■-PN□	EzM2-86L-■-PN□		3, 5, 8, 10	117
Ezi-SERVO II -PE-86XL-■-PN□	EzM2-86XL-■-PN□		3, 5, 8, 10	155

* The code of encoder resolution will be marked in "■"

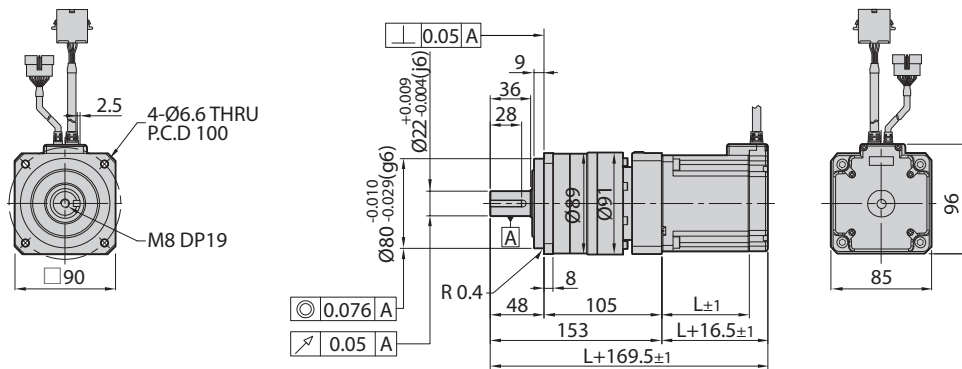

Unit Part Number	Motor	Stage	□ Reduction Gear Ratio	L Length [mm]
Ezi-SERVO II -PE-86M-■-PN□	EzM2-86M-■-PN□	Double Stage	15, 25, 40, 50	78
Ezi-SERVO II -PE-86L-■-PN□	EzM2-86L-■-PN□		15, 25, 40, 50	117
Ezi-SERVO II -PE-86XL-■-PN□	EzM2-86XL-■-PN□		15, 25, 40, 50	155

* The code of encoder resolution will be marked in "■"

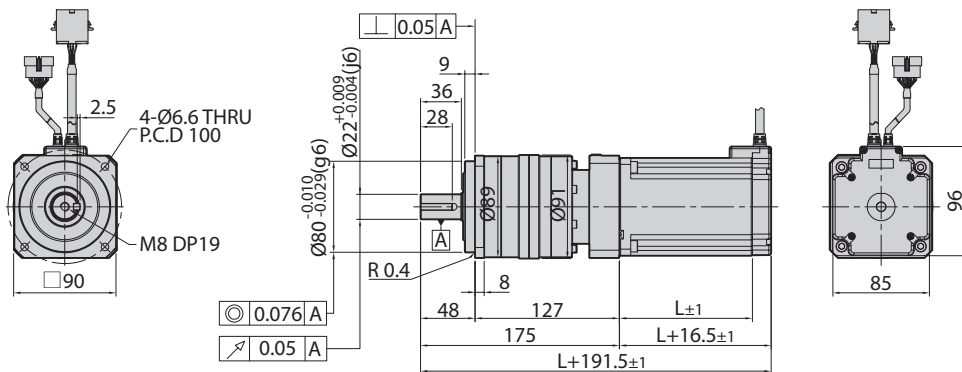

● Settings and Operation

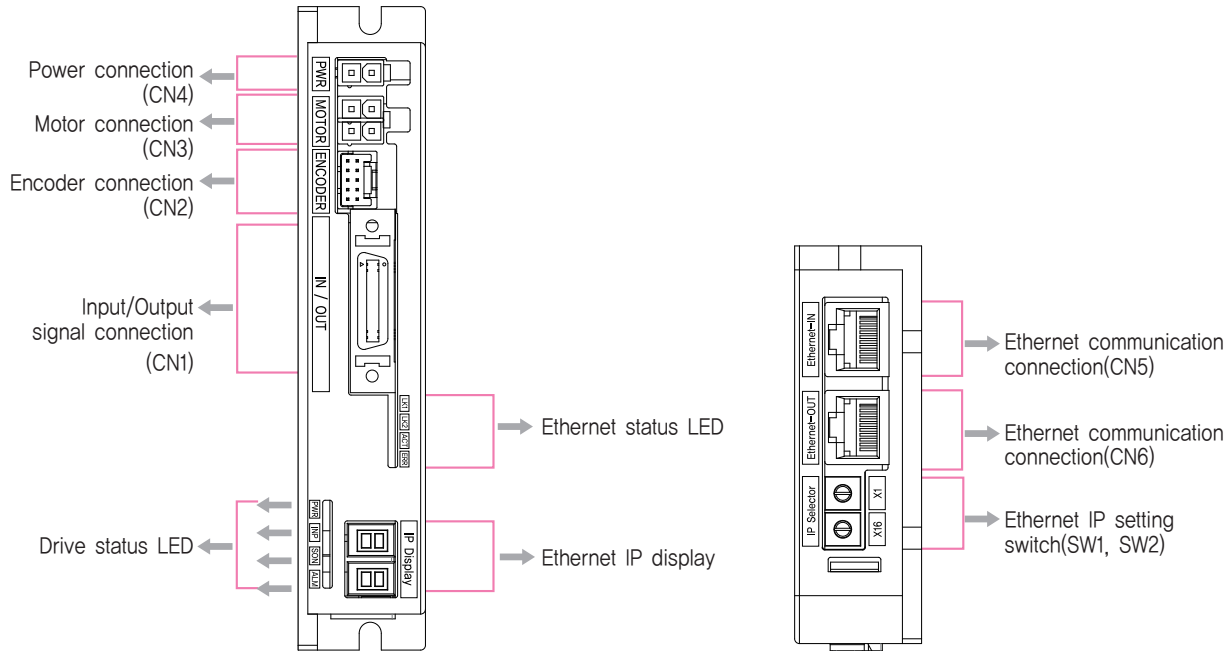

◆ 86mm Motor Drive (EzS2-PE-86 Series)

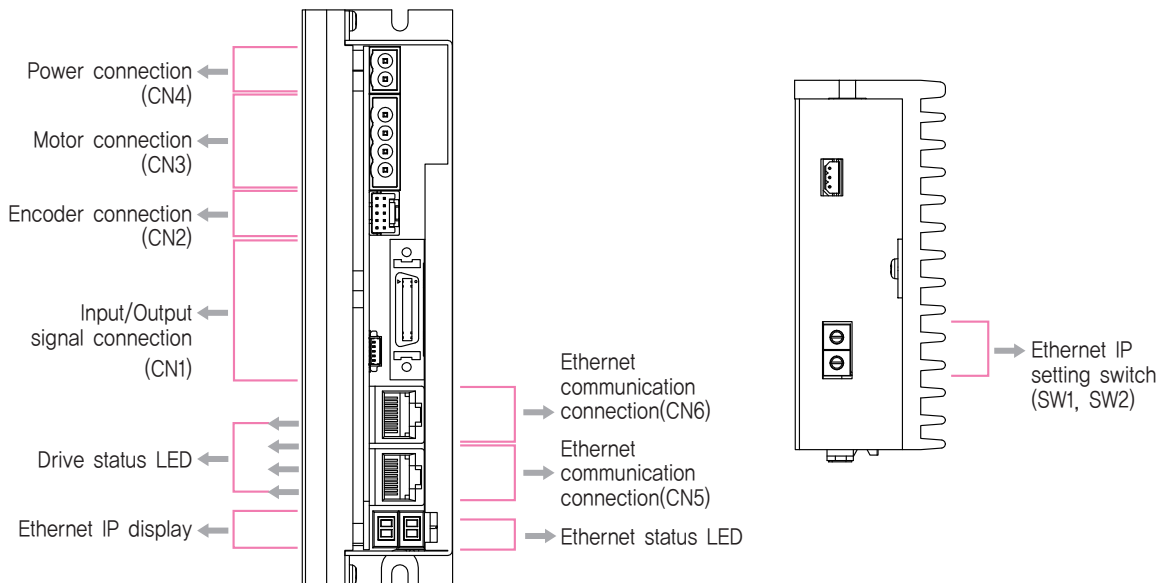

1. Ethernet IP Display and Setting Switch (SW1, SW2)

It is to be set from 1 to 254. Please set the IP not to overlap each other.
(Basic set up is "192.168.0.xxx" and xxx is to be set by switch)

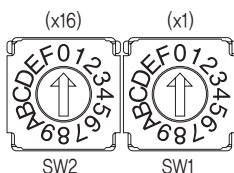
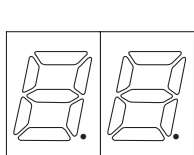

Ex) In case of SW1 : 7 and SW2 : 5
 $(5 \times 16) + (7 \times 1) = 87$
 IP is to be set as 192.168.0.87

2. Ethernet Status LED

LED indicates communication status of Ethernet. Link/Activity LED exists on each port of Ethernet.

Name	Color	Status	Explanation
Error	Red	OFF	No Error status
		ON	Local Error

Name	Color	Status	Explanation
LK1 / LK2	Green	OFF	Link deactivated
		ON	Link activated

Name	Color	Status	Explanation
Activity	Yellow	OFF	No operating
		Flickering	Operating

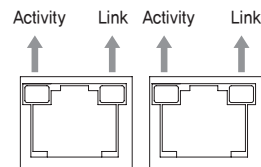
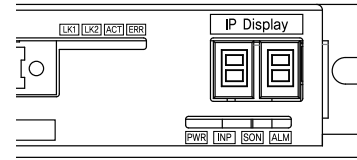

3. Drive Status LED

Indication	Color	Function	ON/OFF Condition
PWR	Green	Power input indication	LED is turned ON when power is applied
INP	Yellow	Complete Positioning Motion	Lights On when Positioning error reaches within the preset pulse selected by parameter
SON	Orange	Servo On / Off Indication	Servo On: Lights On, Servo Off: Lights Off
ALM	Red	Alarm indication	Flash when protection function is activated

◆ Protection functions and LED flash times

Times	Error Code ^{*4}	Protection	Conditions
1	E-001	Over Current Error	The current through power devices in drive exceeds 4.8A ^{*1}
2	E-002	Over Speed Error	Motor speed exceeds 3,000 [rpm]
3	E-003	Position Tracking Error	Position error value is higher than 180° in motor run state ^{*2}
4	E-004	Over Load Error	The motor is continuously operated more than 5 seconds under a load exceeding the max. torque
5	E-005	Over Temperature Error	Temperature of inside of drive exceed 85°C
6	E-006	Over Regenerated Voltage Error	Back-EMF is higher than limit value ^{*3}
7	E-007	Motor Connect Error	The power is ON without connection of the motor cable to drive
8	E-008	Encoder Connect Error	Cable connection error in Encoder connection of drive
10	E-010	In-Position Error	After operation is finished, position error more than 1 pulse is continued for more than 3 seconds
12	E-012	ROM Error	Error occurs in parameter storage device(ROM)
15	E-015	Position Overflow Error	Position error value is higher than 180° in motor stop state ^{*2}

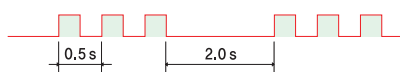

Alarm LED flash
(Ex, Position tracking error)

*1 : Limit value depends on motor model, (Refer to the Manual)

*2 : Default value can be changed by parameter. (Refer to the Manual)

*3 : Voltage limit of Back-EMF depends on motor model, (Refer to the Manual)

*4 : When an alarm occurs, error code is displayed on the 7-segment instead of Ethernet IP.

※ Please refer to user Manual for the details of protection functions.

4. Input/Output Signal Connector(CN1)

NO.	Function	I/O
1	LIMIT+	Input
2	LIMIT-	Input
3	ORIGIN	Input
4	Digital In1	Input
5	Digital In6	Input
6	Digital In7	Input
7	Compare Out	Output
8	Digital Out1	Output
9	Digital Out2	Output
10	Digital Out3	Output
11	Digital Out4	Output
12	Digital Out5	Output
13	Digital Out6	Output
14	Digital In2	Input
15	Digital In3	Input
16	Digital In4	Input
17	Digital In5	Input
18	Digital In8	Input
19	Digital In9	Input
20	Digital Out7	Output
21	Digital Out8	Output
22	Digital Out9	Output
23	BRAKE+	Output
24	BRAKE-	Output
25	EXT_GND	Input
26	EXT_24VDC	Input

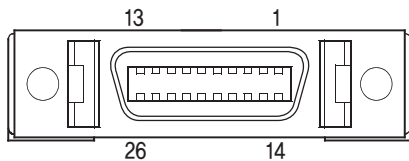

5. Encoder Connector(CN2)

NO.	Function	I/O
1	A+	Input
2	A-	Input
3	B+	Input
4	B-	Input
5	Z+	Input
6	Z-	Input
7	5VDC	Output
8	GND	Output
9	F_GND	----
10	F_GND	----

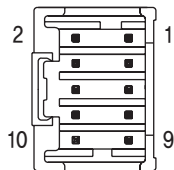

6. Motor Connector(CN3)

NO.	Function	I/O
1	A Phase	Output
2	B Phase	Output
3	/A Phase	Output
4	/B Phase	Output



NO.	Function	I/O
1	/B Phase	Output
2	B Phase	Output
3	/A Phase	Output
4	A Phase	Output

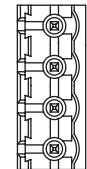

※ 86mm motor drive.

7. Power Connector(CN4)

NO.	Function	I/O
1	24VDC	Input
2	GND	Input



NO.	Function	I/O
1	GND	Input
2	40~70VDC	Input

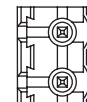

※ 86mm motor drive.

8. Ethernet Communication Connector(CN5, CN6)

NO.	Function	NO.	Function
1	TD+	6	RD-
2	TD-	7	----
3	RD+	8	----
4	----	Connection hood	F_GND
5	----		

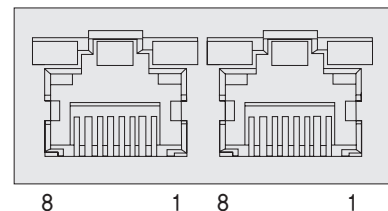

System Configuration

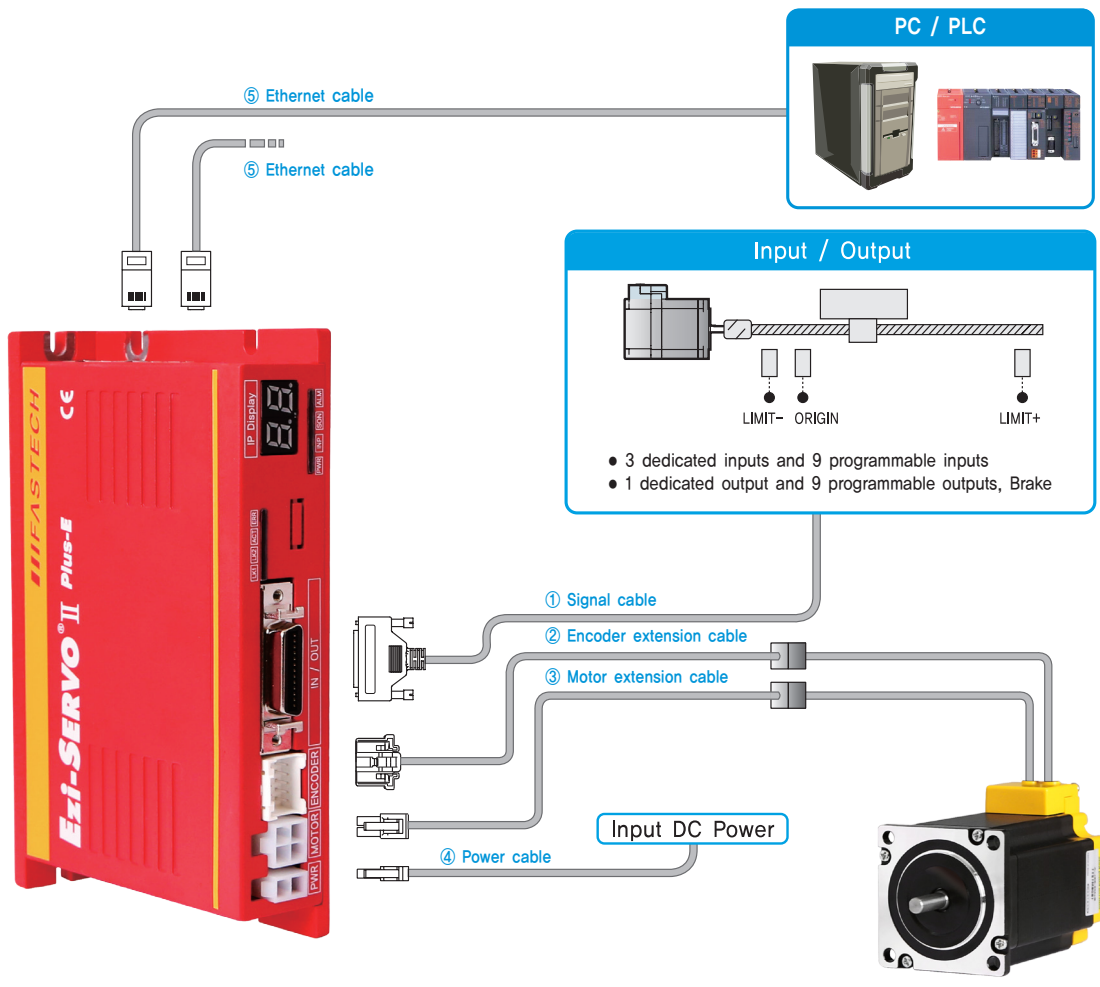

FASTECH Ezi-SERVO II Plus-E

Type	Signal Cable	Encoder Cable	Motor Cable	Power Cable	Ethernet Cable
Length supplied	-	30cm	30cm	-	-
Max. Length	20m	20m	20m	2m	100m

1. Options

① Signal Cable

Available to connect between Input/Output signals and Ezi-SERVO II Plus-E.

Item	Length [m]	Remark
CSVR-S-□□□F	□□□	Normal Cable
CSVR-S-□□□M	□□□	Robot Cable

□ is for Cable Length. The unit is 1m and Max, 20m length.

② Encoder Extension Cable

Available to extended connection between Encoder and Ezi-SERVO II Plus-E.

Item	Length [m]	Remark
CSVO-E-□□□F	□□□	Normal Cable
CSVO-E-□□□M	□□□	Robot Cable

□ is for Cable Length. The unit is 1m and Max, 20m length.

③ Motor Extension Cable

Available to extended connection between motor and Ezi-SERVO II Plus-E.

Item	Length [m]	Remark
CSVO-M-□□□F	□□□	Normal Cable
CSVO-M-□□□M	□□□	Robot Cable

□ is for Cable Length, The unit is 1m and Max, 20m length.

④ Power Cable

Available to connect between Power and Ezi-SERVO II Plus-E.

Item	Length [m]	Remark
CSVO-P-□□□F	□□□	Normal Cable
CSVO-P-□□□M	□□□	Robot Cable

□ is for Cable Length, The unit is 1m and Max, 2m length.

⑤ Ethernet Cable

STP(Shielded twisted pair) cable of category 5e or higher.

Item	Length [m]	Remark
CGNR-EC-□□□F	□□□	Normal Cable

□ is for Cable Length, The unit is 1m and Max, 100m length.

⑥ TB-Plus(Interface Board)

Available to connect more conveniently between Input/Output signal and Ezi-SERVO II Plus-E.

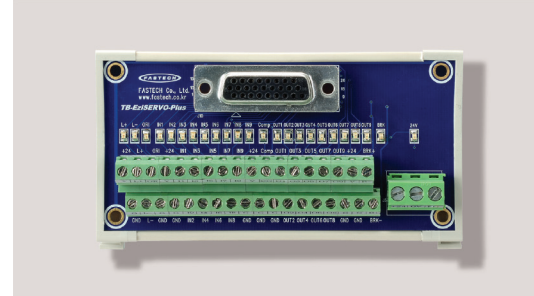

⑦ Interface Cable for TB-Plus

Available to Connect between TB-Plus Interface Board and Ezi-SERVO II Plus-E.

Item	Length [m]	Remark
CIFD-S-□□□F	□□□	Normal Cable
CIFD-S-□□□M	□□□	Robot Cable

□ is for Cable Length, The unit is 1m and Max, 20m length.

2. Connector Specifications

Connector specifications for cabling to drive.

Purpose	Item	Part Number	Manufacturer	
Power (CN4)	Housing Terminal	5557-02R 5556T	MOLEX	
	Motor	Drive Side (CN3)	Housing Terminal	5557-04R 5556T
	Motor Side	Housing Terminal	5557-04R 5556T	MOLEX
Encoder	Drive Side (CN2)	Housing Terminal	51353-1000 56134-9000	MOLEX
	Encoder Side	Housing Terminal	SMP-09V-NC SHF-001T-0,8BS	JST
Signal (CN1)	Connector Backshell	10126-3000PE 10326-52F0-008	3M	

※ Above connector is the most suitable product for the drive applied. Another equivalent connector can be used.

● System Configuration [86mm Motor Drive]

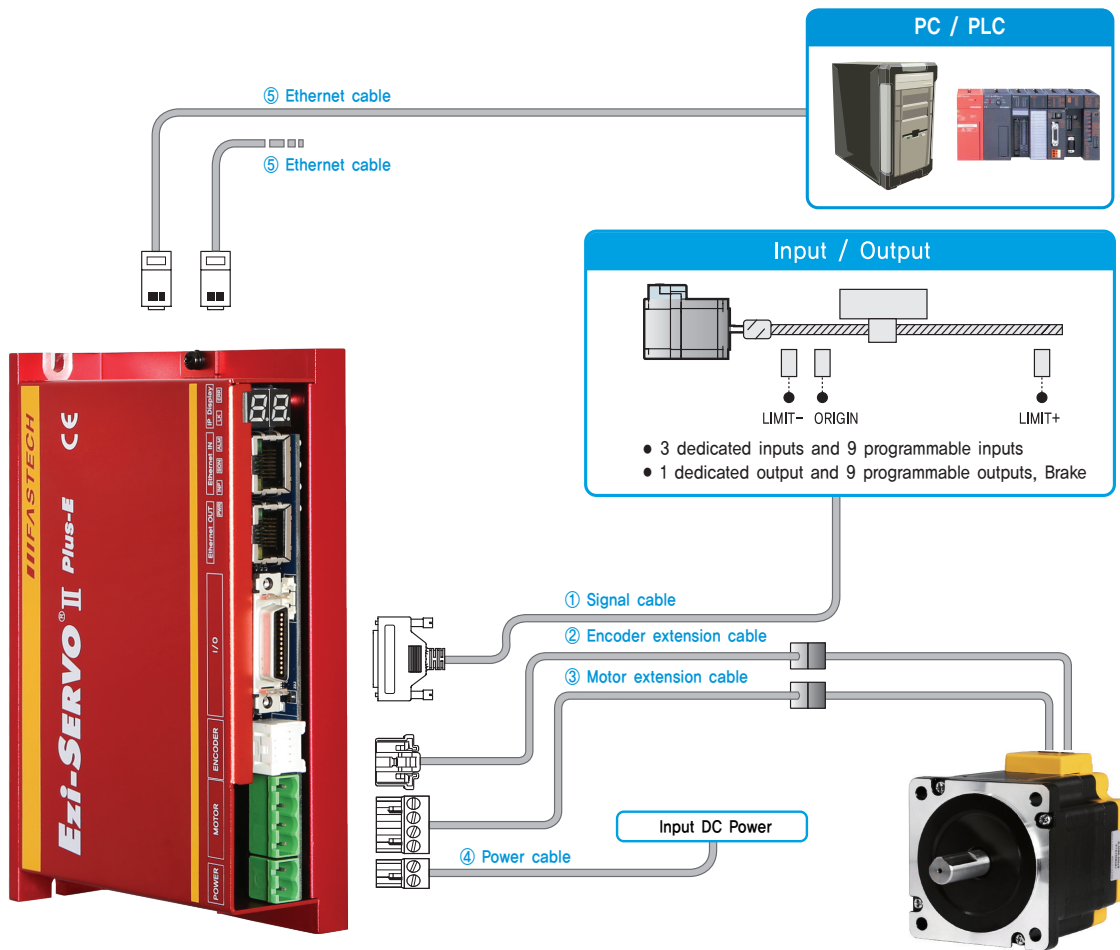

FASTECH Ezi-SERVO II Plus-E

Type	Signal Cable	Encoder Cable	Motor Cable	Power Cable	Ethernet Cable
Length supplied	–	30cm	30cm	–	–
Max. Length	20m	20m	20m	2m	100m

1. Options

① Signal Cable

Available to connect between Input/Output signals and Ezi-SERVO II Plus-E.

Item	Length [m]	Remark
CSVR-S-□□□F	□□□	Normal Cable
CSVR-S-□□□M	□□□	Robot Cable

□ is for Cable Length. The unit is 1m and Max, 20m length.

② Encoder Extension Cable

Available to extended connection between Encoder and Ezi-SERVO II Plus-E.

Item	Length [m]	Remark
CSVO-E-□□□F	□□□	Normal Cable
CSVO-E-□□□M	□□□	Robot Cable

□ is for Cable Length. The unit is 1m and Max, 20m length.

③ Motor Extension Cable

Available to extended connection between motor and Ezi-SERVO II Plus-E.

Item	Length [m]	Remark
CSVP-M-□□□F	□□□	Normal Cable
CSVP-M-□□□M	□□□	Robot Cable

□ is for Cable Length, The unit is 1m and Max. 20m length.

④ Power Cable

Available to connect between Power and Ezi-SERVO II Plus-E.

Item	Length [m]	Remark
CSVP-P-□□□F	□□□	Normal Cable
CSVP-P-□□□M	□□□	Robot Cable

□ is for Cable Length, The unit is 1m and Max. 2m length.

⑤ Ethernet Cable

STP(Shielded twisted pair) cable of category 5e or higher.

Item	Length [m]	Remark
CGNR-EC-□□□F	□□□	Normal Cable

□ is for Cable Length, The unit is 1m and Max. 100m length.

⑥ TB-Plus(Interface Board)

Available to connect more conveniently between Input/Output signal and Ezi-SERVO II Plus-E.

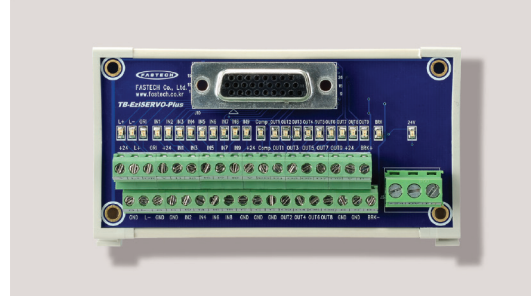

⑦ Interface Cable for TB-Plus

Available to Connect between TB-Plus Interface Board and Ezi-SERVO II Plus-E.

Item	Length [m]	Remark
CIFD-S-□□□F	□□□	Normal Cable
CIFD-S-□□□M	□□□	Robot Cable

□ is for Cable Length, The unit is 1m and Max. 20m length.

2. Connector Specifications

Connector specifications for cabling to drive.

Purpose	Item	Part Number	Manufacture
Power (CN4)	Terminal Block	AK950-2	PTR
Motor	Drive Side (CN3)	Terminal Block	AK950-4
	Motor Side	Housing Terminal	3191-4R1 1381T
Encoder	Drive Side (CN2)	Housing Terminal	51353-1000 56134-9000
	Encoder Side	Housing Terminal	SMP-09V-NC SHF-001T-0,8BS
Signal (CN1)	Connector Backshell	10126-3000PE 10326-52F0-008	3M

※ Above connector is the most suitable product for the drive applied. Another equivalent connector can be used.

External Wiring Diagram

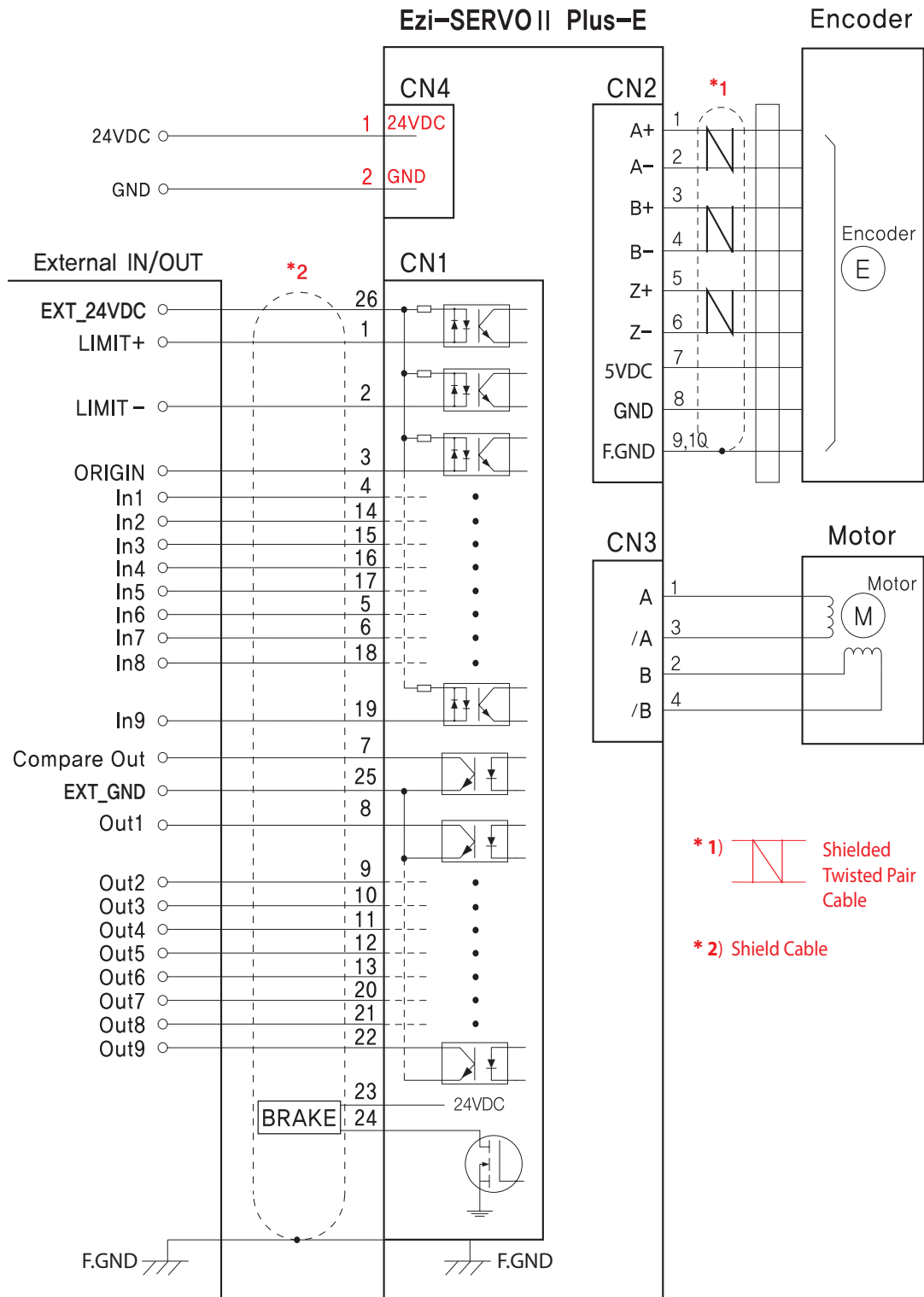

FASTECH Ezi-SERVO II Plus-E

※ When connects I/O cable between controller and drive, please turn off the power of both controller and drive, in order to protect the drive from any damage.

CAUTION

Please refer to the Manual when connects motor extension cable. Careful connection will be required to protect the drive from any damages.

External Wiring Diagram [86mm Motor Drive]

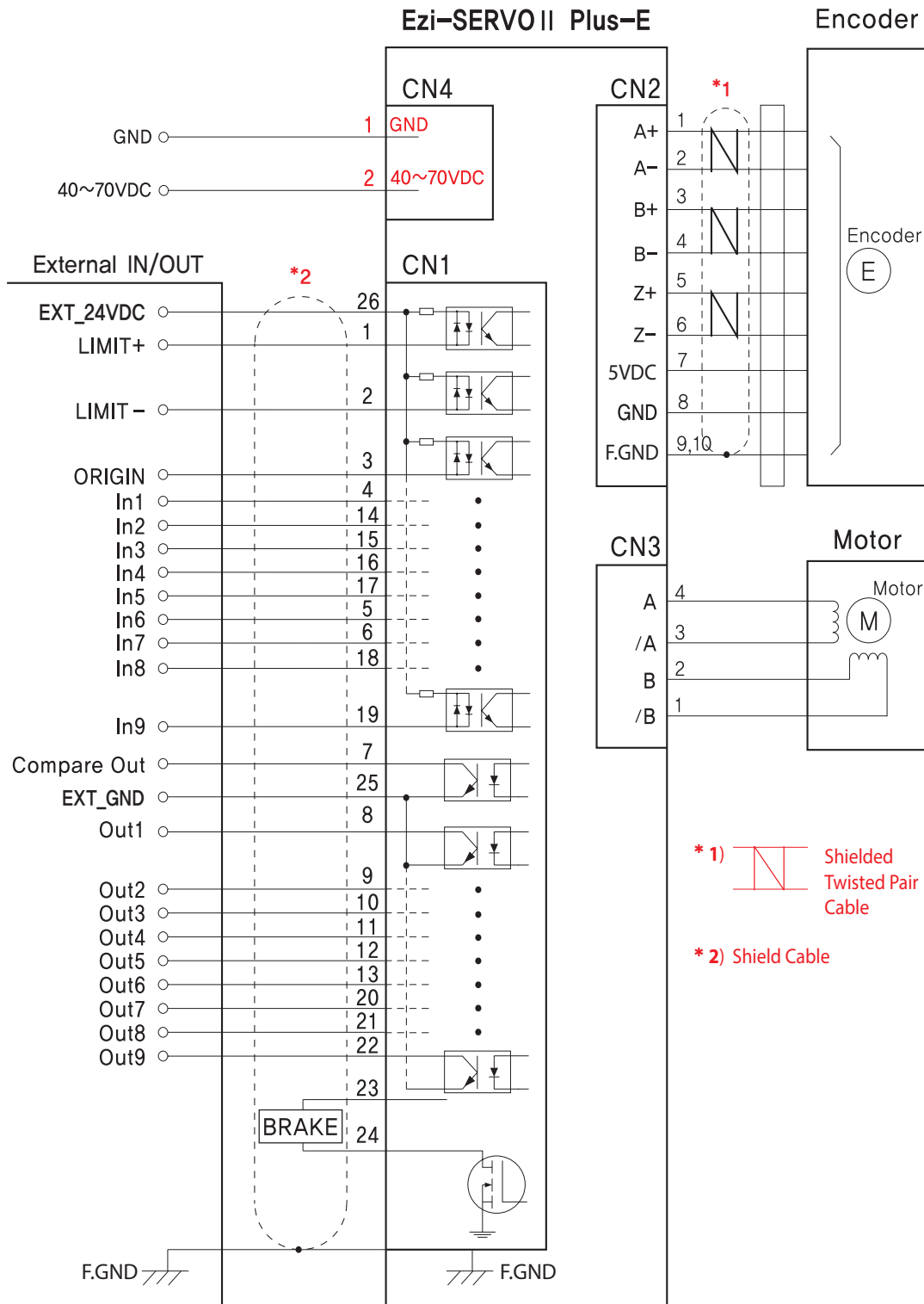

* 1) Shielded Twisted Pair Cable
 * 2) Shield Cable

CAUTION
 Please refer to the Manual when connects motor extension cable.
 Careful connection will be required to protect the drive from any damages.

※ When connects I/O cable between controller and drive, please turn off the power of both controller and drive, in order to protect the drive from any damage.

MEMO

MEMO



Fast, Accurate, Smooth Motion

FASTECH Co., Ltd.

Rm#1101, 401-dong, Bucheon Techno-Park,
655, Pyeongcheon-ro, Bucheon-si Gyeonggi-do,
Republic of Korea (Zip:14502)
TEL : +82-32-234-6300 FAX : +82-32-234-6302
E-mail : fastech@fastech.co.kr
Homepage : www.fastech.co.kr