

S-SERVO[®]

Stepping Motor Control System Without Step Out



Fast, Accurate, Smooth Motion

www.fastech.co.kr

Table of Contents

1. Precautions	1
2. Main Characteristics	4
3. Model and Motor Drive Combination	5
4. Drive Specification and Dimension	10
4.1 Drive Specification	10
4.2 Drive Dimension	11
5. Motor Specification and Size	12
5.1 Standard Motor Specification and Size	12
5.1.1 Motor Specification	12
5.1.2 Torque Characteristic	13
5.1.3 Motor Size	14
5.2 Brake Installed Motor Specification and Size	16
5.2.1 Motor Specification	16
5.2.2 Motor Size	17
5.3 Gearbox Installed Motor Specification and Size	18
5.3.1 Gearbox for 42mm Motor Specification	18
5.3.2 Gearbox for 56mm Motor Specification	20
5.3.3 Gearbox for 60mm Motor Specification	21
5.3.4 Motor Size	22
6. System Configuration	26
6.1 S-SERVO ST Configuration	26
6.1.1 Option Cable	27
6.2 S-SERVO MINI Configuration	28
6.2.1 Option Cable	29
7. Installation and Cabling	30
7.1 Installation Precautions	30
7.2 External Wiring Diagram	31
7.2.1 S-SERVO ST	31
7.2.2 S-SERVO MINI	32
8. Setting and Operating	33
8.1 S-SERVO ST	33
8.1.1 Status Monitor LED	33
8.1.2 Resolution Selection Switch	34
8.1.3 Rotational Direction Selection Switch	34
8.1.4 Pulse Input Selection Switch	34
8.1.5 Power Connector	35
8.1.6 Motor Connector	35
8.1.7 Encoder Connector	35
8.1.8 Input/Output Signal	35
8.1.9 Parameter Connector	35
8.2 S-SERVO MINI	36
8.2.1 Status Monitor LED	36
8.2.2 Resolution Selection Switch	37
8.2.3 Rotational Direction Selection Switch	37
8.2.4 Pulse Input Selection Switch	37
8.2.5 Power Connector	38
8.2.6 Motor Connector	38
8.2.7 Encoder Connector	38
8.2.8 Input/Output Signal	38
8.2.9 Parameter Connector	38
9. Input and Output Signals	39
9.1 Input Signal	39
9.2 Output Signals	40
10. Diagnosis and Rectification of Faults	41
10.1 Alarm LED does not Blink	41
10.2 Alarm LED does Blink	42
	46

※ Before Operation ※

- Thank you for your purchasing S-SERVO ST.
- S-SERVO ST is full digital position control step drive.
- This manual describes handling, maintenance, repair, diagnosis and troubleshooting of S-SERVO ST.
- Before operating S-SERVO ST, thoroughly read this manual.
- After reading the manual, keep the manual near the S-SERVO ST so that any user can read the manual whenever needed.

1. Precautions

◆ General Precautions

- Contents of this manual are subject to change without prior notice for functional improvement, change of specifications or user's better understanding. Thoroughly read the manual provided with the purchased S-SERVO ST.
- When the manual is damaged or lost, please contact with Fastech's agents or our company at the address on the last page of the manual.
- Our company is not responsible for a product breakdown due to user's dismantling for the product, and such a breakdown is not guaranteed by the warranty.

◆ Put the Safety First

- Before installation, operation and repairing the S-SERVO ST, thoroughly read the manual and fully understand the contents. Before operating the S-SERVO ST please, understand the mechanical characteristics of the S-SERVO ST and related safety information and precautions.
- This manual divides safety precautions into **Attention** and **Warning**.



Attention : If user does not properly handle the product, the user may seriously or slightly injured and damages may occur in the machine.





Warning : If user does not properly handle the product, a dangerous situation (such as an electric shock) may occur resulting in deaths or serious injuries.

- Although precaution is only a **Attention**, a serious result could be caused depending on the situation. Follow safety precautions.



◆ Check the Product

 Attention	<p>Check the Product is damaged or parts are missing. Otherwise, the machine may get damaged or the user may get injured.</p>
----------------------------------------------------------------------------------------------------	-----------------------------------------------------------------------------------------------------------------------------------

◆ Installation

 Attention	<p>Carefully move the S-SERVO ST. Otherwise the Product may get damaged or User's foot may get injured by dropping the product.</p> <p>Use non-flammable materials such as metal in the place where the S-SERVO ST is to be installed. Otherwise, a fire may occur.</p> <p>When installing several S-SERVO ST in a sealed place, install a cooling fan to keep the ambient temperature of the S-SERVO ST as 50°C or lower. Otherwise, a fire or other kinds of accidents may occur due to overheating.</p>
 Warning	<p>The process of Installation, Connection, Operation, Checking and Repairing should be done with qualified person. Otherwise, a fire or other kinds of accidents may occur.</p>

◆ Connect Cables

 Attention	<p>Keep the rated range of Input Voltage for S-SERVO ST. Otherwise, a fire or other kinds of accidents may occur.</p> <p>Cable connection should follow the wiring diagram. Otherwise, a fire or other kinds of accidents may occur.</p>
 Warning	<p>Before connecting cables, check if input power is off. Otherwise, an electric shock or a fire may occur.</p> <p>The case of the S-SERVO ST is insulated from the ground of the internal circuit by the condenser. Ground the S-SERVO ST. Otherwise, an electric shock or a fire may occur.</p>

◆ Operation

 Attention	<p>If a protection function(alarm) occurs, firstly remove its cause and then release(alarm reset) the protection function. If you operate continuously without removing its cause, the machine may get damaged or the user may get injured.</p> <p>Do not make Motor Free and make input signal to ON during operation. Motor will stop and stop current will become zero. The machine may get damaged or the user may get injured.</p> <p>Make all input signals to OFF before supply input voltage to S-SERVO ST. The machine may get damaged or the user may get injured by motor operation.</p> <p>All parameter values are set by default factory setting value. Change this value after reading this manual throughly. Otherwise, the machine may get damaged or other kinds of accidents may occur.</p>
----------------------------------------------------------------------------------------------------	-----------------------------------------------------------------------------------------------------------------------------------------------------------------------------------------------------------------------------------------------------------------------------------------------------------------------------------------------------------------------------------------------------------------------------------------------------------------------------------------------------------------------------------------------------------------------------------------------------------------------------------------------------------------------------------------------------------------------------------------------------------------------------------------------------------------------------------------------------

◆ Check and Repair

 Warning	<p>Stop to supply power to the main circuit and wait for a while before checking or repairing the S-SERVO ST. Electricity remaining in the capacitor may cause danger.</p> <p>Do not change cabling while power is being supplied. Otherwise, the user may get injured or the product may get damaged.</p> <p>Do not reconstruct the S-SERVO ST. Otherwise, an electric shock may occur or the reconstructed product can not get After-Service.</p>
----------------------------------------------------------------------------------------------------	-------------------------------------------------------------------------------------------------------------------------------------------------------------------------------------------------------------------------------------------------------------------------------------------------------------------------------------------------------------------------------------------------------------------------------------------------------------------------------

2. Main Characteristics

◆ Completely Free from the Concern of Loss of Position.

(Alarm will be generated when step out)

Because of mounted encoder constantly monitor the current position, step out cannot be occurred. If step out occurred by external force of overloads, alarm signal will be sent to upper controller. Thus, upper controller can recognize step out of step motor

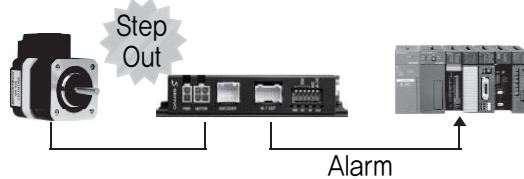

◆ Perfect Positioning Completion Check

(Positioning completion signal will be generated)

When motor stops at the goal position, encoder detect it and send positioning completion signal to upper controller. Therefore S-SERVO resolve the problem of unclear positioning of current Open Loop System

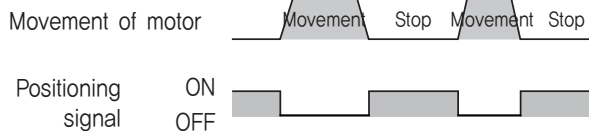

◆ Position Precision is only Related to Encoder

S-SERVO controls position by using high precision of encoder. Regardless of motor type (2 Phase or 5 Phase), S-SERVO position precision is only related to mounted encoder resolution so high precision of positioning is possible unlike open loop micro step motor and driver which adapts 2 Phase or 5 Phase motor.

◆ Reduce the Motor Temperature and Energy Usage

(Current control according to load)

S-SERVO automatically control the motor current according to loads. Thus, febricity of motor and drive are minimized so can save the energy as well.

◆ Complete Stop

It completely stop when motor stops so hunting cannot be occurred. It is suitable for high speed inspection equipment using vision.

Complete stop

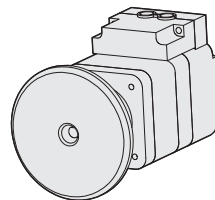

Hunting

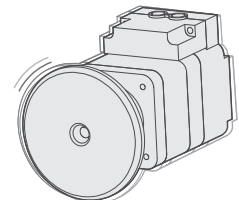

◆ High Torque and High Speed

S-SERVO detect current position by encoder feedback so can keep the high torque against the 100% loads and high speed. Current Open Loop System cannot drive against 100% loads because of false operation by step out.

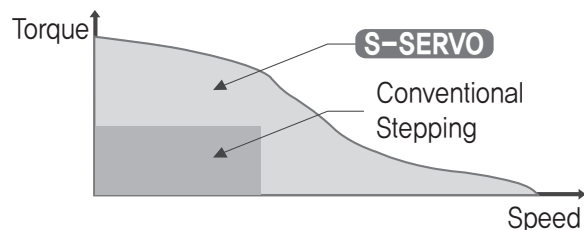

◆ Variety of Protection Functions and Alarm Signal

Drive and equipment can be protected by the alarm(12 kinds) of such as motor connection error, encoder connection error etc.

◆ Variety of Position Command Unit

According to the purpose of usage, S-SERVO offer 16 stage(500~50,000P/R) of position command unit.

3. Model and Motor Drive Combination

S-SERVO ST Part Numbering

S-SERVO-ST-42S-PG-PN10

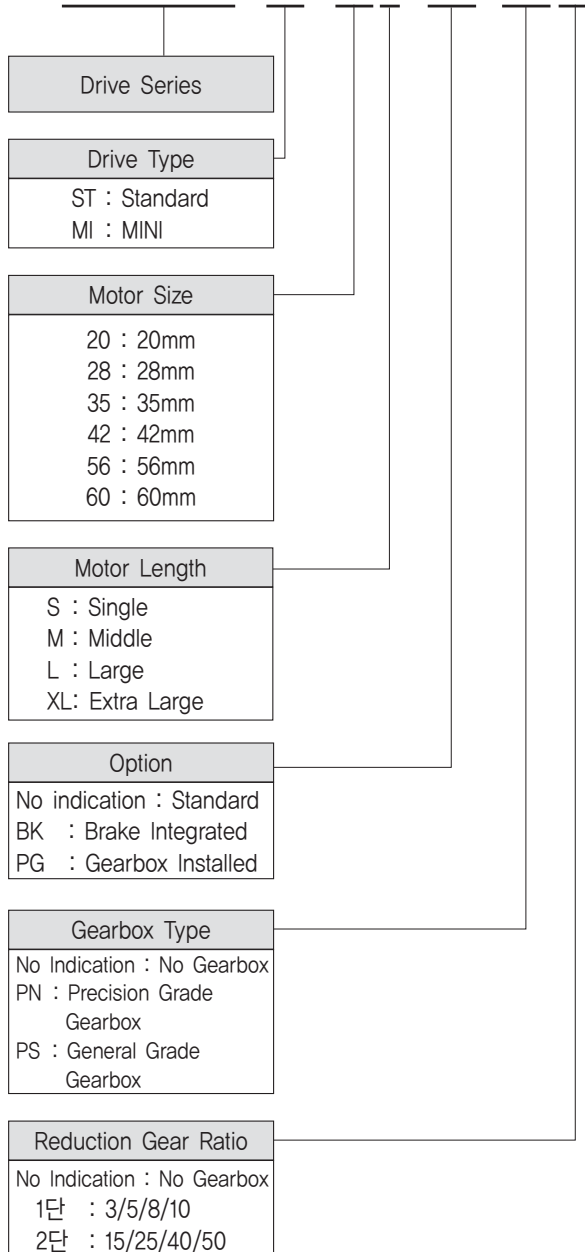

Standard Motor, Drive Combination

◆ S-SERVO ST Drive Products

Unit Part Number	Motor Part Number	Drive Part Number
S-SERVO-ST-20M	SM-20M	SV-PD-20M
S-SERVO-ST-20L	SM-20L	SV-PD-20L
S-SERVO-ST-28S	SM-28S	SV-PD-28S
S-SERVO-ST-28M	SM-28M	SV-PD-28M
S-SERVO-ST-28L	SM-28L	SV-PD-28L
S-SERVO-ST-35M	SM-35M	SV-PD-35M
S-SERVO-ST-35L	SM-35L	SV-PD-35L
S-SERVO-ST-42S	SM-42S	SV-PD-42S
S-SERVO-ST-42M	SM-42M	SV-PD-42M
S-SERVO-ST-42L	SM-42L	SV-PD-42L
S-SERVO-ST-42XL	SM-42XL	SV-PD-42XL
S-SERVO-ST-56S	SM-56S	SV-PD-56S
S-SERVO-ST-56M	SM-56M	SV-PD-56M
S-SERVO-ST-56L	SM-56L	SV-PD-56L
S-SERVO-ST-60S	SM-60S	SV-PD-60S
S-SERVO-ST-60M	SM-60M	SV-PD-60M
S-SERVO-ST-60L	SM-60L	SV-PD-60L

◆ S-SERVO MINI Drive Products

Unit Part Number	Motor Part Number	Drive Part Number
S-SERVO-MI-20M	SM-20M	SV-PD-MI-20M
S-SERVO-MI-20L	SM-20L	SV-PD-MI-20L
S-SERVO-MI-28S	SM-28S	SV-PD-MI-28S
S-SERVO-MI-28M	SM-28M	SV-PD-MI-28M
S-SERVO-MI-28L	SM-28L	SV-PD-MI-28L
S-SERVO-MI-35M	SM-35M	SV-PD-MI-35M
S-SERVO-MI-35L	SM-35L	SV-PD-MI-35L
S-SERVO-MI-42S	SM-42S	SV-PD-MI-42S
S-SERVO-MI-42M	SM-42M	SV-PD-MI-42M
S-SERVO-MI-42L	SM-42L	SV-PD-MI-42L
S-SERVO-MI-42XL	SM-42XL	SV-PD-MI-42XL

Brake Integrated Motor, Drive Combination

◆ S-SERVO ST Drive Products

Unit Part Number	Motor Part Number	Drive Part Number
S-SERVO-ST-42S-BK	SM-42S-BK	SV-PD-42S-BK
S-SERVO-ST-42M-BK	SM-42M-BK	SV-PD-42M-BK
S-SERVO-ST-42L-BK	SM-42L-BK	SV-PD-42L-BK
S-SERVO-ST-42XL-BK	SM-42XL-BK	SV-PD-42XL-BK
S-SERVO-ST-56S-BK	SM-56S-BK	SV-PD-56S-BK
S-SERVO-ST-56M-BK	SM-56M-BK	SV-PD-56M-BK
S-SERVO-ST-56L-BK	SM-56L-BK	SV-PD-56L-BK
S-SERVO-ST-60S-BK	SM-60S-BK	SV-PD-60S-BK
S-SERVO-ST-60M-BK	SM-60M-BK	SV-PD-60M-BK
S-SERVO-ST-60L-BK	SM-60L-BK	SV-PD-60L-BK

◆ S-SERVO MINI Drive Products

Unit Part Number	Motor Part Number	Drive Part Number
S-SERVO-MI-42S-BK	SM-42S-BK	SV-PD-MI-42S-BK
S-SERVO-MI-42M-BK	SM-42M-BK	SV-PD-MI-42M-BK
S-SERVO-MI-42L-BK	SM-42L-BK	SV-PD-MI-42L-BK
S-SERVO-MI-42XL-BK	SM-42XL-BK	SV-PD-MI-42XL-BK

Gearbox Integrated Motor, Drive Combination

◆ S-SERVO ST Drive Products

Unit Part Number	Motor Part Number	Drive Part Number	Reduction Gear Ratio	
S-SERVO-ST-42S-PG-PN3	SM-42S-PG-PN3	SV-PD-42S	1:3	
S-SERVO-ST-42S-PG-PN5	SM-42S-PG-PN5		1:5	
S-SERVO-ST-42S-PG-PN8	SM-42S-PG-PN8		1:8	
S-SERVO-ST-42S-PG-PN10	SM-42S-PG-PN10		1:10	
S-SERVO-ST-42S-PG-PN15	SM-42S-PG-PN15		1:15	
S-SERVO-ST-42S-PG-PN25	SM-42S-PG-PN25		1:25	
S-SERVO-ST-42S-PG-PN40	SM-42S-PG-PN40		1:40	
S-SERVO-ST-42S-PG-PN50	SM-42S-PG-PN50		1:50	
S-SERVO-ST-42M-PG-PN3	SM-42M-PG-PN3		SV-PD-42M	1:3
S-SERVO-ST-42M-PG-PN5	SM-42M-PG-PN5			1:5
S-SERVO-ST-42M-PG-PN8	SM-42M-PG-PN8	1:8		
S-SERVO-ST-42M-PG-PN10	SM-42M-PG-PN10	1:10		
S-SERVO-ST-42M-PG-PN15	SM-42M-PG-PN15	1:15		
S-SERVO-ST-42M-PG-PN25	SM-42M-PG-PN25	1:25		
S-SERVO-ST-42M-PG-PN40	SM-42M-PG-PN40	1:40		
S-SERVO-ST-42M-PG-PN50	SM-42M-PG-PN50	1:50		
S-SERVO-ST-42L-PG-PN3	SM-42L-PG-PN3	SV-PD-42L	1:3	
S-SERVO-ST-42L-PG-PN5	SM-42L-PG-PN5		1:5	
S-SERVO-ST-42L-PG-PN8	SM-42L-PG-PN8		1:8	
S-SERVO-ST-42L-PG-PN10	SM-42L-PG-PN10		1:10	
S-SERVO-ST-42L-PG-PN15	SM-42L-PG-PN15		1:15	
S-SERVO-ST-42L-PG-PN25	SM-42L-PG-PN25		1:25	
S-SERVO-ST-42L-PG-PN40	SM-42L-PG-PN40		1:40	
S-SERVO-ST-42L-PG-PN50	SM-42L-PG-PN50		1:50	

Gearbox Integrated Motor, Drive Combination

◆ S-SERVO ST Drive Products

Unit Part Number	Motor Part Number	Drive Part Number	Reduction Gear Ratio
S-SERVO-ST-42XL-PG-PN3	SM-42XL-PG-PN3	SV-PD-42XL	1:3
S-SERVO-ST-42XL-PG-PN5	SM-42XL-PG-PN5		1:5
S-SERVO-ST-42XL-PG-PN8	SM-42XL-PG-PN8		1:8
S-SERVO-ST-42XL-PG-PN10	SM-42XL-PG-PN10		1:10
S-SERVO-ST-42XL-PG-PN15	SM-42XL-PG-PN15		1:15
S-SERVO-ST-42XL-PG-PN25	SM-42XL-PG-PN25		1:25
S-SERVO-ST-42XL-PG-PN40	SM-42XL-PG-PN40		1:40
S-SERVO-ST-42XL-PG-PN50	SM-42XL-PG-PN50		1:50
S-SERVO-ST-56S-PG-PN3	SM-56S-PG-PN3	SV-PD-56S	1:3
S-SERVO-ST-56S-PG-PN5	SM-56S-PG-PN5		1:5
S-SERVO-ST-56S-PG-PN8	SM-56S-PG-PN8		1:8
S-SERVO-ST-56S-PG-PN10	SM-56S-PG-PN10		1:10
S-SERVO-ST-56S-PG-PN15	SM-56S-PG-PN15		1:15
S-SERVO-ST-56S-PG-PN25	SM-56S-PG-PN25		1:25
S-SERVO-ST-56S-PG-PN40	SM-56S-PG-PN40		1:40
S-SERVO-ST-56S-PG-PN50	SM-56S-PG-PN50		1:50
S-SERVO-ST-56M-PG-PN3	SM-56M-PG-PN3	SV-PD-56M	1:3
S-SERVO-ST-56M-PG-PN5	SM-56M-PG-PN5		1:5
S-SERVO-ST-56M-PG-PN8	SM-56M-PG-PN8		1:8
S-SERVO-ST-56M-PG-PN10	SM-56M-PG-PN10		1:10
S-SERVO-ST-56M-PG-PN15	SM-56M-PG-PN15		1:15
S-SERVO-ST-56M-PG-PN25	SM-56M-PG-PN25		1:25
S-SERVO-ST-56M-PG-PN40	SM-56M-PG-PN40		1:40
S-SERVO-ST-56M-PG-PN50	SM-56M-PG-PN50		1:50
S-SERVO-ST-56L-PG-PN3	SM-56L-PG-PN3	SV-PD-56L	1:3
S-SERVO-ST-56L-PG-PN5	SM-56L-PG-PN5		1:5
S-SERVO-ST-56L-PG-PN8	SM-56L-PG-PN8		1:8
S-SERVO-ST-56L-PG-PN10	SM-56L-PG-PN10		1:10
S-SERVO-ST-56L-PG-PN15	SM-56L-PG-PN15		1:15
S-SERVO-ST-56L-PG-PN25	SM-56L-PG-PN25		1:25
S-SERVO-ST-56L-PG-PN40	SM-56L-PG-PN40		1:40
S-SERVO-ST-56L-PG-PN50	SM-56L-PG-PN50		1:50

Gearbox Integrated Motor, Drive Combination

◆ S-SERVO ST Drive Products

Unit Part Number	Motor Part Number	Drive Part Number	Reduction Gear Ratio
S-SERVO-ST-60S-PG-PN3	SM-60S-PG-PN3	SV-PD-60S	1:3
S-SERVO-ST-60S-PG-PN5	SM-60S-PG-PN5		1:5
S-SERVO-ST-60S-PG-PN8	SM-60S-PG-PN8		1:8
S-SERVO-ST-60S-PG-PN10	SM-60S-PG-PN10		1:10
S-SERVO-ST-60S-PG-PN15	SM-60S-PG-PN15		1:15
S-SERVO-ST-60S-PG-PN25	SM-60S-PG-PN25		1:25
S-SERVO-ST-60S-PG-PN40	SM-60S-PG-PN40		1:40
S-SERVO-ST-60S-PG-PN50	SM-60S-PG-PN50		1:50
S-SERVO-ST-60M-PG-PN3	SM-60M-PG-PN3	SV-PD-60M	1:3
S-SERVO-ST-60M-PG-PN5	SM-60M-PG-PN5		1:5
S-SERVO-ST-60M-PG-PN8	SM-60M-PG-PN8		1:8
S-SERVO-ST-60M-PG-PN10	SM-60M-PG-PN10		1:10
S-SERVO-ST-60M-PG-PN15	SM-60M-PG-PN15		1:15
S-SERVO-ST-60M-PG-PN25	SM-60M-PG-PN25		1:25
S-SERVO-ST-60M-PG-PN40	SM-60M-PG-PN40		1:40
S-SERVO-ST-60M-PG-PN50	SM-60M-PG-PN50		1:50
S-SERVO-ST-60L-PG-PN3	SM-60L-PG-PN3	SV-PD-60L	1:3
S-SERVO-ST-60L-PG-PN5	SM-60L-PG-PN5		1:5
S-SERVO-ST-60L-PG-PN8	SM-60L-PG-PN8		1:8
S-SERVO-ST-60L-PG-PN10	SM-60L-PG-PN10		1:10
S-SERVO-ST-60L-PG-PN15	SM-60L-PG-PN15		1:15
S-SERVO-ST-60L-PG-PN25	SM-60L-PG-PN25		1:25
S-SERVO-ST-60L-PG-PN40	SM-60L-PG-PN40		1:40
S-SERVO-ST-60L-PG-PN50	SM-60L-PG-PN50		1:50

Gearbox Integrated Motor, Drive Combination

◆ S-SERVO MINI Drive Products

Unit Part Number	Motor Part Number	Drive Part Number	Reduction Gear Ratio
S-SERVO-MI-42S-PG-PN3	SM-42S-PG-PN3	SV-PD-MI-42S	1:3
S-SERVO-MI-42S-PG-PN5	SM-42S-PG-PN5		1:5
S-SERVO-MI-42S-PG-PN8	SM-42S-PG-PN8		1:8
S-SERVO-MI-42S-PG-PN10	SM-42S-PG-PN10		1:10
S-SERVO-MI-42S-PG-PN15	SM-42S-PG-PN15		1:15
S-SERVO-MI-42S-PG-PN25	SM-42S-PG-PN25		1:25
S-SERVO-MI-42S-PG-PN40	SM-42S-PG-PN40		1:40
S-SERVO-MI-42S-PG-PN50	SM-42S-PG-PN50		1:50
S-SERVO-MI-42M-PG-PN3	SM-42M-PG-PN3	SV-PD-MI-42M	1:3
S-SERVO-MI-42M-PG-PN5	SM-42M-PG-PN5		1:5
S-SERVO-MI-42M-PG-PN8	SM-42M-PG-PN8		1:8
S-SERVO-MI-42M-PG-PN10	SM-42M-PG-PN10		1:10
S-SERVO-MI-42M-PG-PN15	SM-42M-PG-PN15		1:15
S-SERVO-MI-42M-PG-PN25	SM-42M-PG-PN25		1:25
S-SERVO-MI-42M-PG-PN40	SM-42M-PG-PN40		1:40
S-SERVO-MI-42M-PG-PN50	SM-42M-PG-PN50		1:50
S-SERVO-MI-42L-PG-PN3	SM-42L-PG-PN3	SV-PD-MI-42L	1:3
S-SERVO-MI-42L-PG-PN5	SM-42L-PG-PN5		1:5
S-SERVO-MI-42L-PG-PN8	SM-42L-PG-PN8		1:8
S-SERVO-MI-42L-PG-PN10	SM-42L-PG-PN10		1:10
S-SERVO-MI-42L-PG-PN15	SM-42L-PG-PN15		1:15
S-SERVO-MI-42L-PG-PN25	SM-42L-PG-PN25		1:25
S-SERVO-MI-42L-PG-PN40	SM-42L-PG-PN40		1:40
S-SERVO-MI-42L-PG-PN50	SM-42L-PG-PN50		1:50
S-SERVO-MI-42XL-PG-PN3	SM-42XL-PG-PN3	SV-PD-MI-42XL	1:3
S-SERVO-MI-42XL-PG-PN5	SM-42XL-PG-PN5		1:5
S-SERVO-MI-42XL-PG-PN8	SM-42XL-PG-PN8		1:8
S-SERVO-MI-42XL-PG-PN10	SM-42XL-PG-PN10		1:10
S-SERVO-MI-42XL-PG-PN15	SM-42XL-PG-PN15		1:15
S-SERVO-MI-42XL-PG-PN25	SM-42XL-PG-PN25		1:25
S-SERVO-MI-42XL-PG-PN40	SM-42XL-PG-PN40		1:40
S-SERVO-MI-42XL-PG-PN50	SM-42XL-PG-PN50		1:50

4. Drive Specification and Dimension

4.1 Drive Specifications

Motor Model	SM-20 series	SM-28 series	SM-35 series	SM-42 series	SM-56 series	SM-60 series
Drive Type	SV-PD-20 series	SV-PD-28 series	SV-PD-35 series	SV-PD-42 series	SV-PD-56 series	SV-PD-60 series
	SV-PD-MI-20 series	SV-PD-MI-28 series	SV-PD-MI-35 series	SV-PD-MI-42 series	-	-
Input Voltage	24VDC ± 10%					
Control Method	Closed Loop control by ARM-based 32-bit MCU					
Current Consumption	Max 500mA (Except motor current)					
Operating Condition	Temperature	In use : 0~50°C In Storage : -20~70°C				
	Humidity	In use : 35~85%RH (Non-condensing) In Storage : 10~90%RH (Non-condensing)				
	Vib. Resist	0.5G				
Functions *2	Rotation Speed	0~3,000rpm*1				
	Resolution (P/R)	500 1,000 1,600 2,000 3,200 3,600 4,000 5,000 6,400 8,000 10,000 20,000 25,000 36,000 40,000 50,000 (Selectable by DIP switch)				
	Maximum Input	500KHz (Duty 50%)				
	Protection Functions	Over Current Error, Over Speed Error, Position Tracking Error, Over Load Error, Over Temperature Error, Over Regenerated Voltage Error, Motor Connection Error, Encoder Connection Error, Motor Voltage Error, In-Position Error, ROM Error, Position Overflow Error				
	LED Display	Power status, In-position status, Enable status, Alarm status				
	STOP Current	20%~100% (Setting by using GUI) When motor stop operation, 0.1 second after motor current will be set to STOP current value. STOP current value is a percentage of the rated current of motor. * Default : 50%				
	Pulse Input Method	1-Pulse/2-Pulse (Selectable by DIP switch)				
	Rotational Direction	CW/CCW (Selectable by DIP switch)				
	Speed/Position Control Command	Pulse input				
Input *3 Output Signal	Input Signal Functions	Position command pulse, Enable, Alarm reset (Photocoupler input)				
	Output Signal Functions	In-Position, Alarm (Photocoupler output)				

*1 Maximum speed is variable according to resolution. Maximum speed is 3,000rpm until resolution 10,000. Over the 10,000 resolution, maximum rotation speed will be reduced. Calculation is as follows

$$\text{Maximum rotation speed} = \frac{500\text{kHz}}{\text{Resolution}} \times 60$$

*2 Please refer to 「Setting and operating」 (33page) to obtain detailed function information

*3 Please refer to 「Control Input/Output explanation」 (39Page) to obtain detailed Input/Output signal information

4.2 Drive Size

◆ S-SERVO ST Series

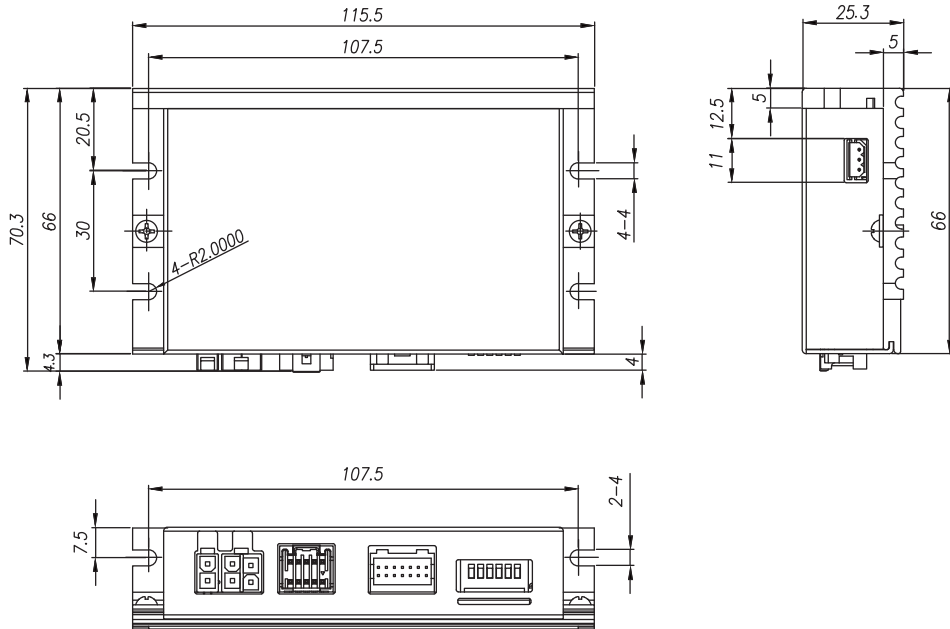

◆ S-SERVO MINI Series

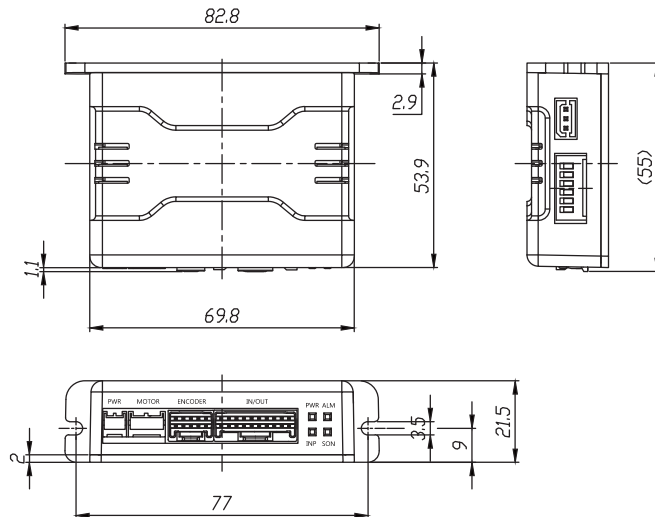

5. Motor Specification and Size

5.1 Standard Motor Specification and Size

5.1.1 Motor Specification

20

28

35

Model	Unit	SM-20M	SM-20L	SM-28S	SM-28M	SM-28L	SM-35M	SM-35L
Current per Phase	A	0.6	0.6	0.67	0.67	0.67	0.8	1
Holding Torque	N · m	0.020	0.039	0.059	0.093	0.118	0.078	0.137
Rotor Inertia	g · cm ²	2.5	5	9	12	18	10	14
Weight	g	70	80	110	140	200	120	180
Length(L)	mm	33	38	32	45	51	26	36

42

56

60

Model	Unit	SM-42S	SM-42M	SM-42L	SM-42XL	SM-56S	SM-56M	SM-56L	SM-60S	SM-60M	SM-60L
Current per Phase	A	1.33	1.68	1.68	1.2	2.8	2.8	2.8	4	4	4
Holding Torque	N · m	0.216	0.353	0.431	0.65	0.539	1.236	1.853	0.873	1.285	2.401
Rotor Inertia	g · cm ²	35	54	68	114	120	275	480	140	320	800
Weight	g	220	280	350	500	470	700	1000	600	900	1600
Length(L)	mm	33	39	47	59	41	56	76	46	56	85

5.1.2 Torque Characteristic

20

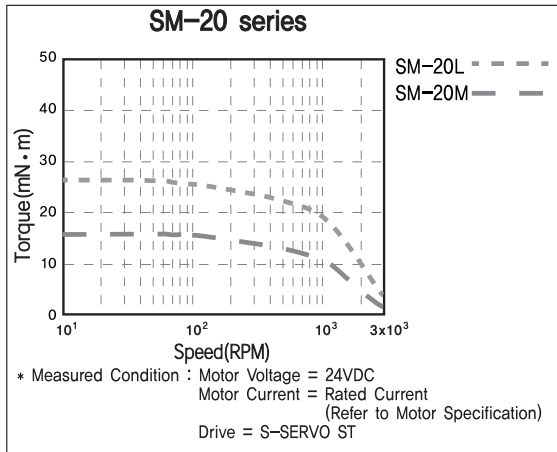

28

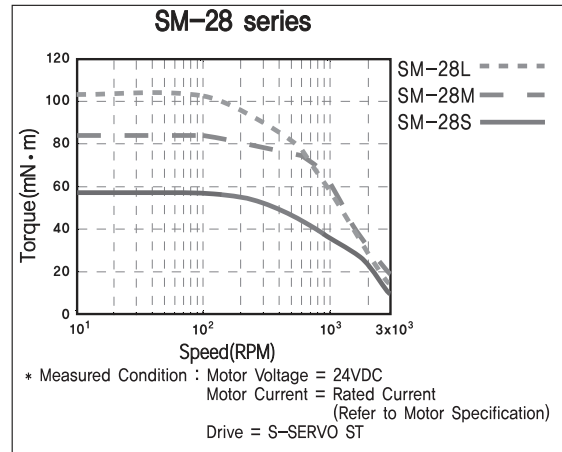

35

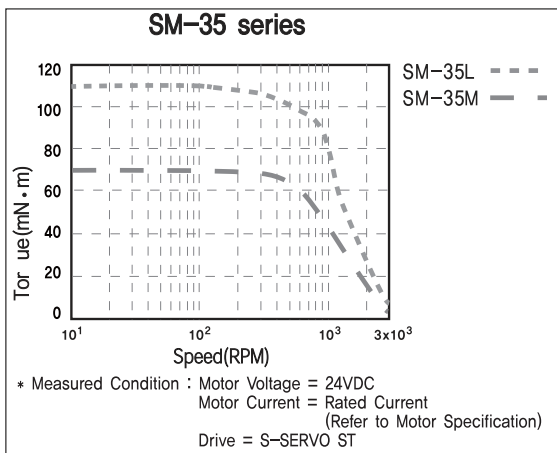

42

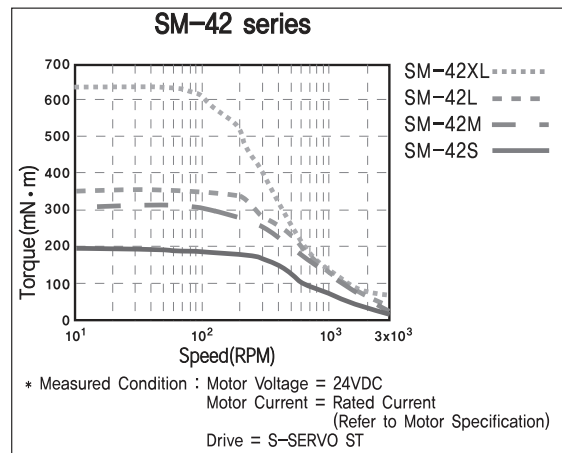

56

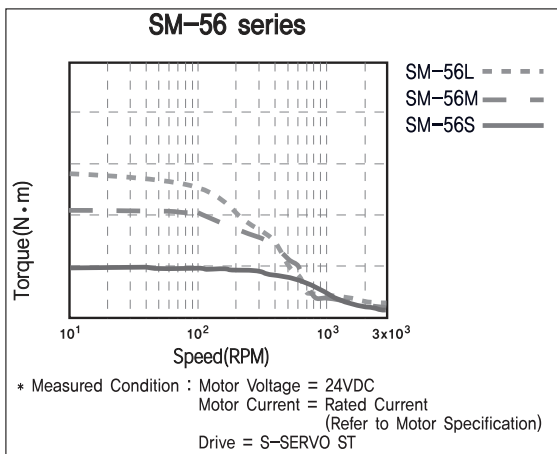

60

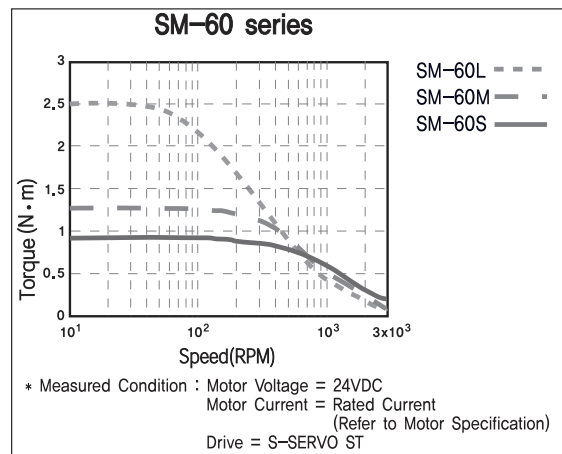

5.1.3 Motor Size

20

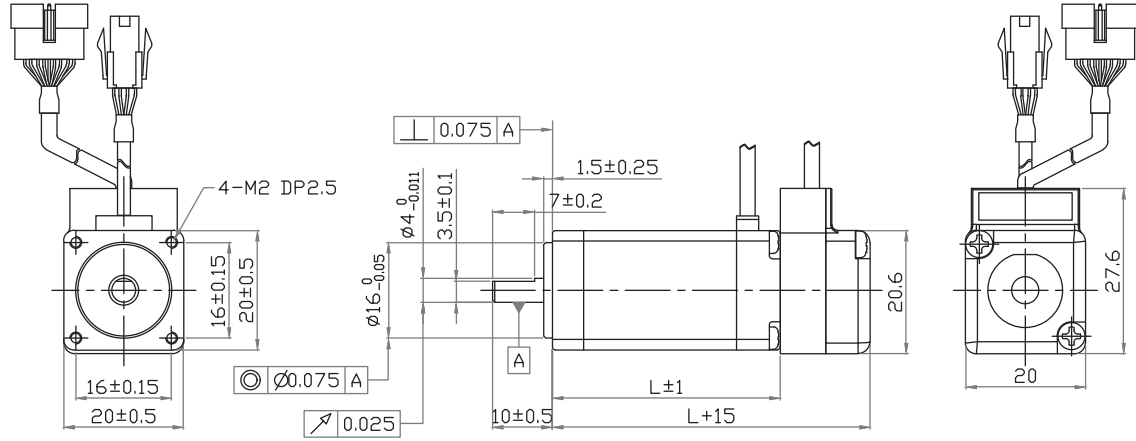

28

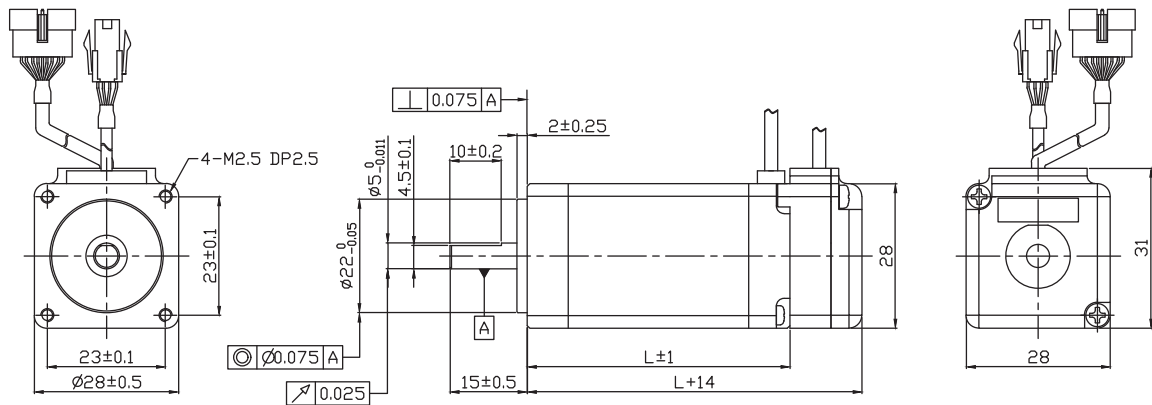

35

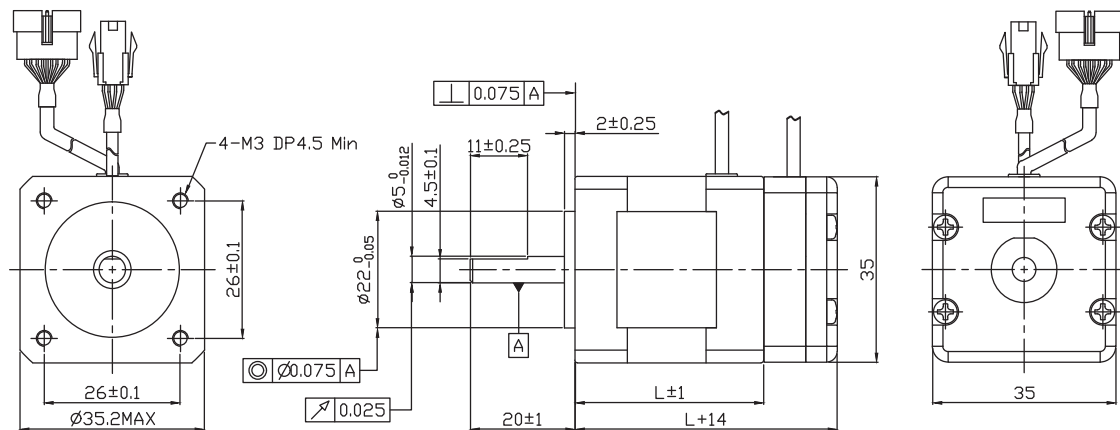

42

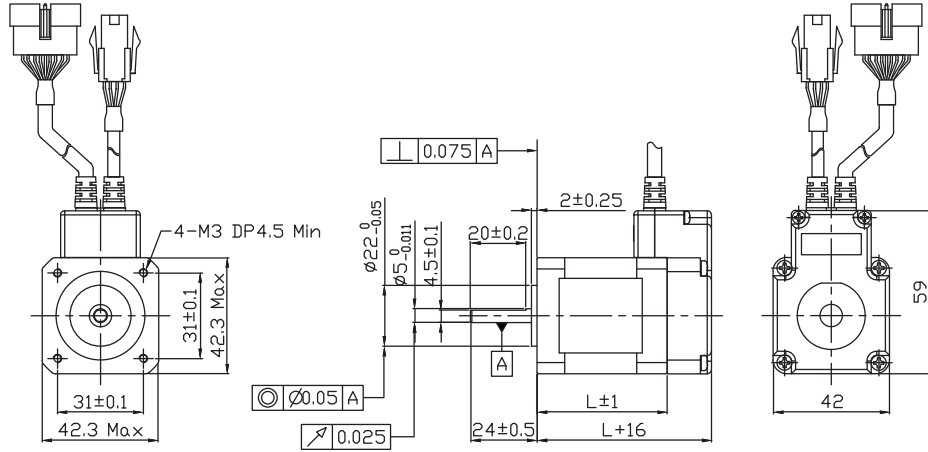

56

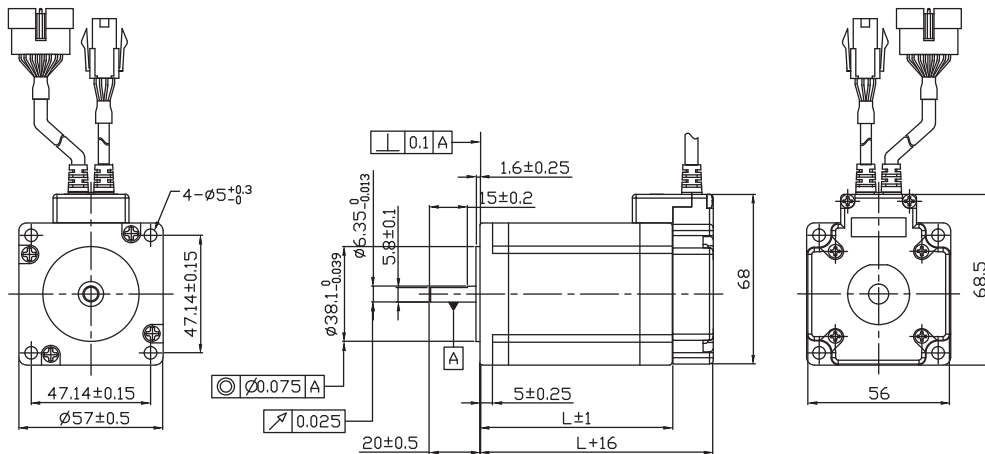

60

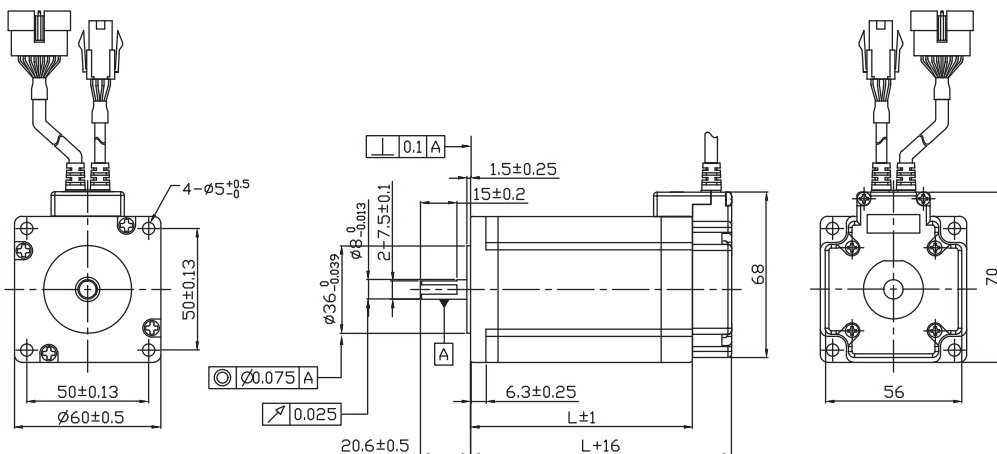

5.2 Brake Installed Motor Specification and Size

5.2.1 Motor Specification

Unit Part Number	Model Name	Electronic Brake					Motor Unit Weight (g)	Permitted Over-hung Load (N)				Permitted Thrust Load (N)
		Type	Voltage Input (V)	Rated Current (A)	Power Consumption	Statical Friction Torque (N · m)		Length from Motor Point (mm)				
								3	8	13	18	
S-SERVO-ST-42S-BK S-SERVO-MI-42S-BK	SM-42S-BK	Non-excitation run Type	24VDC ±10%	0.3A ±10%	8.2	0.2	510	22	26	33	46	Must be Lower than Unit's Weight
S-SERVO-ST-42M-BK S-SERVO-MI-42M-BK	SM-42M-BK						570					
S-SERVO-ST-42L-BK S-SERVO-MI-42L-BK	SM-42L-BK						640					
S-SERVO-ST-42XL-BK S-SERVO-MI-42XL-BK	SM-42XL-BK				770							
S-SERVO-56S-BK	SM-56S-BK				7.5	0.7	870	52	65	85	123	
S-SERVO-56M-BK	SM-56M-BK						1190					
S-SERVO-56L-BK	SM-56L-BK						1380					
S-SERVO-60S-BK	SM-60S-BK				7.5	0.7	1150	70	87	114	165	
S-SERVO-60M-BK	SM-60M-BK						1350					
S-SERVO-60L-BK	SM-60L-BK						1960					

- * Electronic Brake cannot be used for braking. Position hold purpose only when power OFF.
- * The weight means Motor Unit Weight including Motor and Electronic Brake.
- * Motor Model Name is combined model name of Motor and Brake.
- * Motor specification and torque characteristic are same as Standard Motor.

* Brake Operation Timing Chart

S-SERVO ST control Brake by Drive automatically.

Please refer to below Timing Chart when control Brake from upper controller other than using S-SERVO ST Brake control. Otherwise, Drive malfunctioning and loads can be fall down.

Also, please do not operate Brake while motor operation to prevent damage.

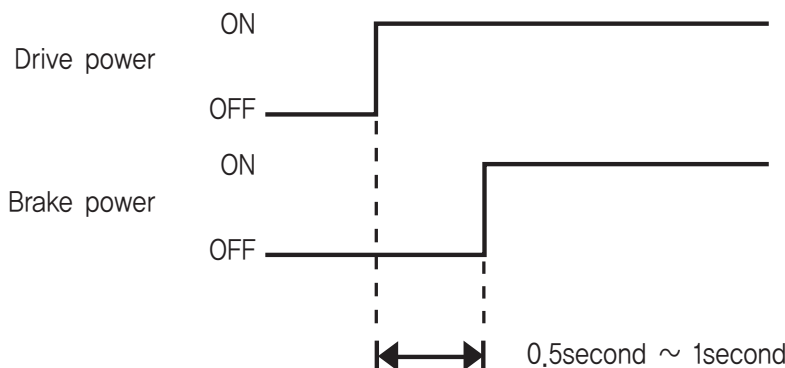

5.2.2 Motor Size

42

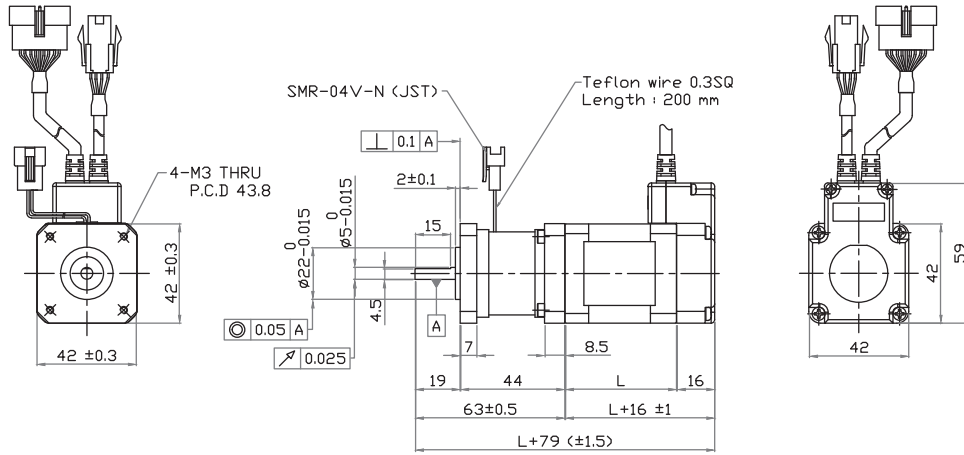

56

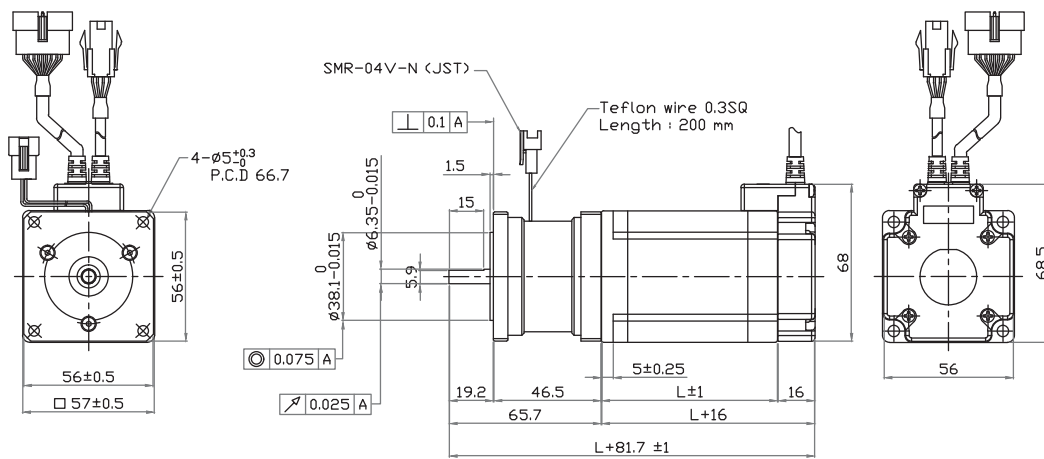

60

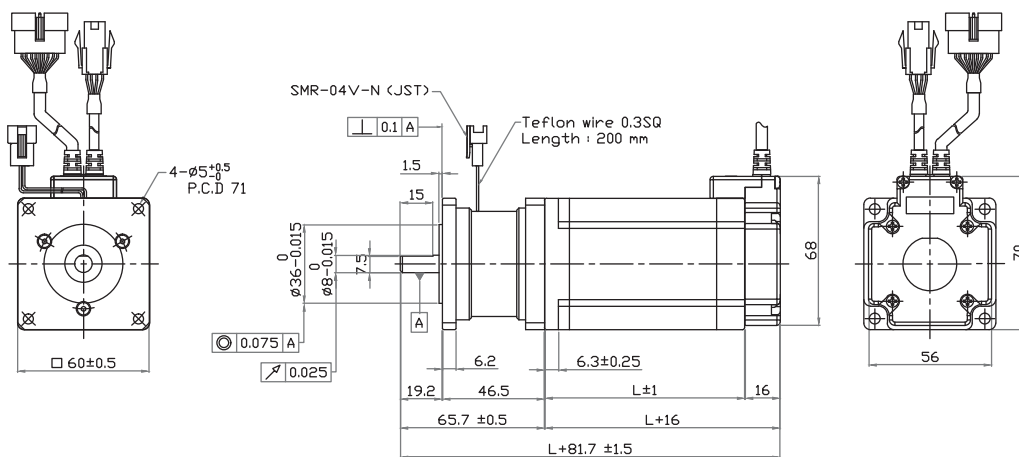

5.3 Gearbox Installed Motor Specification and Size

5.3.1 Gearbox for 42mm Motor Specification

Model Name	Maximum Holding Torque (N · m)	Rotor Inertia Moment (Kg · m ²)	Back-lash (min)	Angle Transmission Error (min)	Reduction Gear Ratio	Resolution (10,000ppr Standard)	Permitted Torque (N · m)	Maximum Torque (N · m)	Permitted Speed Range (rpm)	Unit Weight (Kg)	Permitted Overhung Load (N)	Permitted Thrust Load (N)	
											Axis Center Standard		
S-SERVO-ST-42S-PG-PN3 S-SERVO-MI-42S-PG-PN3	0.8	35x10 ⁻⁷	3	5	3	0.012 °	6	18	0~1000	0.89	240	270	
S-SERVO-ST-42S-PG-PN5 S-SERVO-MI-42S-PG-PN5	1.4				5	0.0072 °	9	18	0~600		290	330	
S-SERVO-ST-42S-PG-PN8 S-SERVO-MI-42S-PG-PN8					8	0.0045 °	9	18	0~375		340	410	
S-SERVO-ST-42S-PG-PN10 S-SERVO-MI-42S-PG-PN10					2.7	10	0.0036 °	6	12		0~333	360	450
S-SERVO-ST-42S-PG-PN15 S-SERVO-MI-42S-PG-PN15	4.0		5	7	15	0.0024 °	6	12	0~300	0.99	410	540	
S-SERVO-ST-42S-PG-PN25 S-SERVO-MI-42S-PG-PN25	6.6				25	0.00144 °	9	18	0~120		490	640	
S-SERVO-ST-42S-PG-PN40 S-SERVO-MI-42S-PG-PN40	9.0				40	0.0009 °	9	18	0~75		570	640	
S-SERVO-ST-42S-PG-PN50 S-SERVO-MI-42S-PG-PN50					50	0.00072 °	9	18	0~60		620	640	
S-SERVO-ST-42M-PG-PN3 S-SERVO-MI-42M-PG-PN3	1.1		54x10 ⁻⁷	3	5	3	0.012 °	6	18	0~1000	0.96	240	270
S-SERVO-ST-42M-PG-PN5 S-SERVO-MI-42M-PG-PN5	1.9					5	0.0072 °	9	18	0~600		290	330
S-SERVO-ST-42M-PG-PN8 S-SERVO-MI-42M-PG-PN8		8				0.0045 °	9	18	0~375	340		410	
S-SERVO-ST-42M-PG-PN10 S-SERVO-MI-42M-PG-PN10		3.7				10	0.0036 °	6	12	0~333		360	450
S-SERVO-ST-42M-PG-PN15 S-SERVO-MI-42M-PG-PN15	5.4	5		7	15	0.0024 °	6	12	0~300	1.06	410	540	
S-SERVO-ST-42M-PG-PN25 S-SERVO-MI-42M-PG-PN25	9.0				25	0.00144 °	9	18	0~120		490	640	
S-SERVO-ST-42M-PG-PN40 S-SERVO-MI-42M-PG-PN40					40	0.0009 °	9	18	0~75		570	640	
S-SERVO-ST-42M-PG-PN50 S-SERVO-MI-42M-PG-PN50					50	0.00072 °	9	18	0~60		620	640	

5.3.1 Gearbox for 42mm Motor Specification

Model Name	Maximum Holding Torque (N · m)	Rotor Inertia Moment (Kg · m ²)	Backlash (min)	Angle Transmission Error (min)	Reduction Gear Ratio	Resolution (10,000ppr Standard)	Permitted Torque (N · m)	Maximum Torque (N · m)	Permitted Speed Range (rpm)	Unit Weight (Kg)	Permitted Overhung Load (N)	Permitted Thrust Load (N)
											Axis Center Standard	
S-SERVO-ST-42L-PG-PN3 S-SERVO-MI-42L-PG-PN3	1.4	77x10 ⁻⁷	3	5	3	0.012 °	6	18	0~1000	1.02	240	270
S-SERVO-ST-42L-PG-PN5 S-SERVO-MI-42L-PG-PN5	2.4				5	0.0072 °	9	18	0~600		290	330
S-SERVO-ST-42L-PG-PN8 S-SERVO-MI-42L-PG-PN8	3.8				8	0.0045 °	9	18	0~375		340	410
S-SERVO-ST-42L-PG-PN10 S-SERVO-MI-42L-PG-PN10	4.7				10	0.0036 °	6	12	0~333		360	450
S-SERVO-ST-42L-PG-PN15 S-SERVO-MI-42L-PG-PN15	6.0		5	7	15	0.0024 °	6	12	0~300	1.12	410	540
S-SERVO-ST-42L-PG-PN25 S-SERVO-MI-42L-PG-PN25	9.0				25	0.00144 °	9	18	0~120		490	640
S-SERVO-ST-42L-PG-PN40 S-SERVO-MI-42L-PG-PN40					40	0.0009 °	9	18	0~75		570	640
S-SERVO-ST-42L-PG-PN50 S-SERVO-MI-42L-PG-PN50					50	0.00072 °	9	18	0~60		620	640
S-SERVO-ST-42XL-PG-PN3 S-SERVO-MI-42XL-PG-PN3	1.8	114x10 ⁻⁷	3	5	3	0.012 °	6	18	0~1000	1.15	240	270
S-SERVO-ST-42XL-PG-PN5 S-SERVO-MI-42XL-PG-PN5	3.0				5	0.0072 °	9	18	0~600		290	330
S-SERVO-ST-42XL-PG-PN8 S-SERVO-MI-42XL-PG-PN8	4.8				8	0.0045 °	9	18	0~375		340	410
S-SERVO-ST-42XL-PG-PN10 S-SERVO-MI-42XL-PG-PN10	6.0				10	0.0036 °	6	12	0~333		360	450
S-SERVO-ST-42XL-PG-PN15 S-SERVO-MI-42XL-PG-PN15			5	7	15	0.0024 °	6	12	0~300	1.25	410	540
S-SERVO-ST-42XL-PG-PN25 S-SERVO-MI-42XL-PG-PN25					25	0.00144 °	9	18	0~120		490	640
S-SERVO-ST-42XL-PG-PN40 S-SERVO-MI-42XL-PG-PN40					9.0	40	0.0009 °	9	18		0~75	570
S-SERVO-ST-42XL-PG-PN50 S-SERVO-MI-42XL-PG-PN50	50					0.00072 °	9	18	0~60		620	640

5.3.2 Gearbox for 56mm Motor Specification

Model Name	Maximum Holding Torque (N · m)	Rotor Inertia Moment (Kg · m ²)	Back-lash (min)	Angle Transmission Error (min)	Reduction Gear Ratio	Resolution (10,000ppr Standard)	Permitted Torque (N · m)	Maximum Torque (N · m)	Permitted Speed Range (rpm)	Unit Weight (Kg)	Permitted Overhung Load (N)	Permitted Thrust Load (N)
											Axis Center Standard	
S-SERVO-ST-56S-PG-PN3	1.6	120x10 ⁻⁷	3	5	3	0.012 °	27	50	0~1000	1.34	430	310
S-SERVO-ST-56S-PG-PN5	2.7				5	0.0072 °	27	50	0~600	1.88	510	390
S-SERVO-ST-56S-PG-PN8	4.3				8	0.0045 °	27	50	0~375		600	480
S-SERVO-ST-56S-PG-PN10	5.3				10	0.0036 °	18	35	0~333	2.08	640	530
S-SERVO-ST-56S-PG-PN15	7.7				15	0.0024 °	18	35	0~300		740	630
S-SERVO-ST-56S-PG-PN25	12.9				25	0.00144 °	27	50	0~120	2.08	870	790
S-SERVO-ST-56S-PG-PN40	20.6				40	0.0009 °	27	50	0~75		1000	970
S-SERVO-ST-56S-PG-PN50	25.8				50	0.00072 °	27	50	0~60		1100	1000
S-SERVO-ST-56M-PG-PN3	2.6	200x10 ⁻⁷	3	5	3	0.0012 °	18	35	0~1000	1.4	430	310
S-SERVO-ST-56M-PG-PN5	4.4				5	0.0072 °	27	50	0~600	2.15	510	390
S-SERVO-ST-56M-PG-PN8	7.0				8	0.0045 °	27	50	0~375		600	480
S-SERVO-ST-56M-PG-PN10	8.7				10	0.0036 °	18	35	0~333	2.35	640	530
S-SERVO-ST-56M-PG-PN15	12.7				15	0.0024 °	18	35	0~300		740	630
S-SERVO-ST-56M-PG-PN25	21.1				25	0.00144 °	27	50	0~120	2.35	870	790
S-SERVO-ST-56M-PG-PN40	27.0				40	0.0009 °	27	50	0~75		1000	970
S-SERVO-ST-56M-PG-PN50					50	0.00072 °	27	50	0~60		1100	1000
S-SERVO-ST-56L-PG-PN3	4.3	480x10 ⁻⁷	3	5	3	0.012 °	18	35	0~1000	1.1	430	310
S-SERVO-ST-56L-PG-PN5	7.2				5	0.0072 °	27	50	0~600	2.22	510	390
S-SERVO-ST-56L-PG-PN8	11.4				8	0.0045 °	27	50	0~375		600	480
S-SERVO-ST-56L-PG-PN10	14.3				10	0.0036 °	18	35	0~333	2.42	640	530
S-SERVO-ST-56L-PG-PN15	18.0				15	0.0024 °	18	35	0~300		740	630
S-SERVO-ST-56L-PG-PN25	27.0				25	0.00144 °	27	50	0~120	2.42	870	790
S-SERVO-ST-56L-PG-PN40					40	0.0009 °	27	50	0~75		1000	970
S-SERVO-ST-56L-PG-PN50					50	0.00072 °	27	50	0~60		1100	1000

5.3.3 Gearbox for 60mm Motor Specification

Model Name	Maximum Holding Torque (N · m)	Rotor Inertia Moment (Kg · m ²)	Backlash (min)	Angle Transmission Error (min)	Reduction Gear Ratio	Resolution (10,000ppr Standard)	Permitted Torque (N · m)	Maximum Torque (N · m)	Permitted Speed Range (rpm)	Unit Weight (Kg)	Permitted Overhung Load (N)	Permitted Thrust Load (N)	
											Axis Center Standard		
S-SERVO-ST-60S-PG-PN3	2.6	140x10 ⁻⁷	3	5	3	0.012 °	18	35	0~1000	1.4	430	310	
S-SERVO-ST-60S-PG-PN5	4.4				5	0.0072 °	27	50	0~600		2.0	510	390
S-SERVO-ST-60S-PG-PN8	7.0				8	0.0045 °	27	50	0~375			600	480
S-SERVO-ST-60S-PG-PN10	8.8				10	0.0036 °	18	35	0~333	2.2	640	530	
S-SERVO-ST-60S-PG-PN15	12.7				15	0.0024 °	18	35	0~300		740	630	
S-SERVO-ST-60S-PG-PN25	21.2				25	0.00144 °	27	50	0~120		870	790	
S-SERVO-ST-60S-PG-PN40	27.0				40	0.0009 °	27	50	0~75		1000	970	
S-SERVO-ST-60S-PG-PN50					50	0.00072 °	27	50	0~60		1100	1000	
S-SERVO-ST-60M-PG-PN3	3.6	320x10 ⁻⁷	3	5	3	0.012 °	18	35	0~1000	1.4	430	310	
S-SERVO-ST-60M-PG-PN5	6.0				5	0.0072 °	27	50	0~600		2.3	510	390
S-SERVO-ST-60M-PG-PN8	9.6				8	0.0045 °	27	50	0~375			600	480
S-SERVO-ST-60M-PG-PN10	12.0				10	0.0036 °	18	35	0~333	2.5	640	530	
S-SERVO-ST-60M-PG-PN15	17.4				15	0.0024 °	18	35	0~300		740	630	
S-SERVO-ST-60M-PG-PN25	27.0				25	0.00144 °	27	50	0~120		870	790	
S-SERVO-ST-60M-PG-PN40					40	0.0009 °	27	50	0~75		1000	970	
S-SERVO-ST-60M-PG-PN50					50	0.00072 °	27	50	0~60		1100	1000	
S-SERVO-ST-60L-PG-PN3	7.1	800x10 ⁻⁷	3	5	3	0.012 °	18	35	0~1000	1.4	430	310	
S-SERVO-ST-60L-PG-PN5	11.9				5	0.0072 °	27	50	0~600		3.0	510	390
S-SERVO-ST-60L-PG-PN8	19.0				8	0.0045 °	27	50	0~375			600	480
S-SERVO-ST-60L-PG-PN10	18.0				10	0.0036 °	18	35	0~333	3.2	640	530	
S-SERVO-ST-60L-PG-PN15					15	0.0024 °	18	35	0~300		740	630	
S-SERVO-ST-60L-PG-PN25					25	0.00144 °	27	50	0~120		870	790	
S-SERVO-ST-60L-PG-PN40	27.0				40	0.0009 °	27	50	0~75		1000	970	
S-SERVO-ST-60L-PG-PN50					50	0.00072 °	27	50	0~60		1100	1000	

5.3.4 Motor Size(mm)

42

Model Name	Applied Motor Model Name	Stage	□Second Stage	L Length (mm)
S-SERVO-ST-42S-PG-PN□ S-SERVO-MI-42S-PG-PN□	SM-42S-PG-PN□	Single Stage	3, 5, 8, 10	33
S-SERVO-ST-42M-PG-PN□ S-SERVO-MI-42M-PG-PN□	SM-42M-PG-PN□		3, 5, 8, 10	39
S-SERVO-ST-42L-PG-PN□ S-SERVO-MI-42L-PG-PN□	SM-42L-PG-PN□		3, 5, 8, 10	47
S-SERVO-ST-42XL-PG-PN□ S-SERVO-MI-42XL-PG-PN□	SM-42XL-PG-PN□		3, 5, 8, 10	59

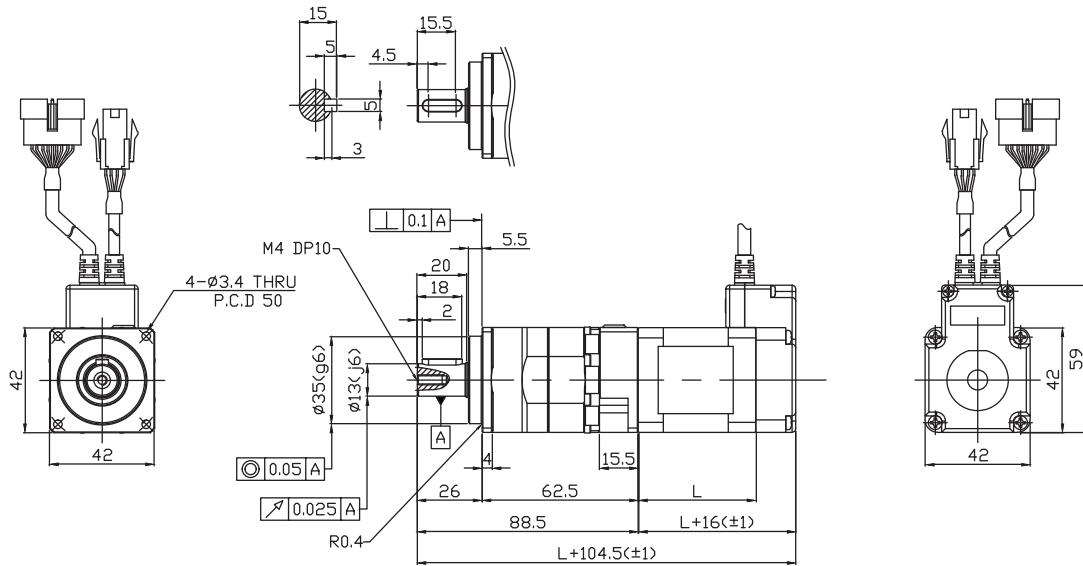

42

Model Name	Applied Motor Model Name	Stage	□ Second Stage	L Length (mm)
S-SERVO-ST-42S-PG-PN□ S-SERVO-MI-42S-PG-PN□	SM-42S-PG-PN□	Second Stage	15, 25, 40, 50	33
S-SERVO-ST-42M-PG-PN□ S-SERVO-MI-42M-PG-PN□	SM-42M-PG-PN□		15, 25, 40, 50	39
S-SERVO-ST-42L-PG-PN□ S-SERVO-MI-42L-PG-PN□	SM-42L-PG-PN□		15, 25, 40, 50	47
S-SERVO-ST-42XL-PG-PN□ S-SERVO-MI-42XL-PG-PN□	SM-42XL-PG-PN□		15, 25, 40, 50	59

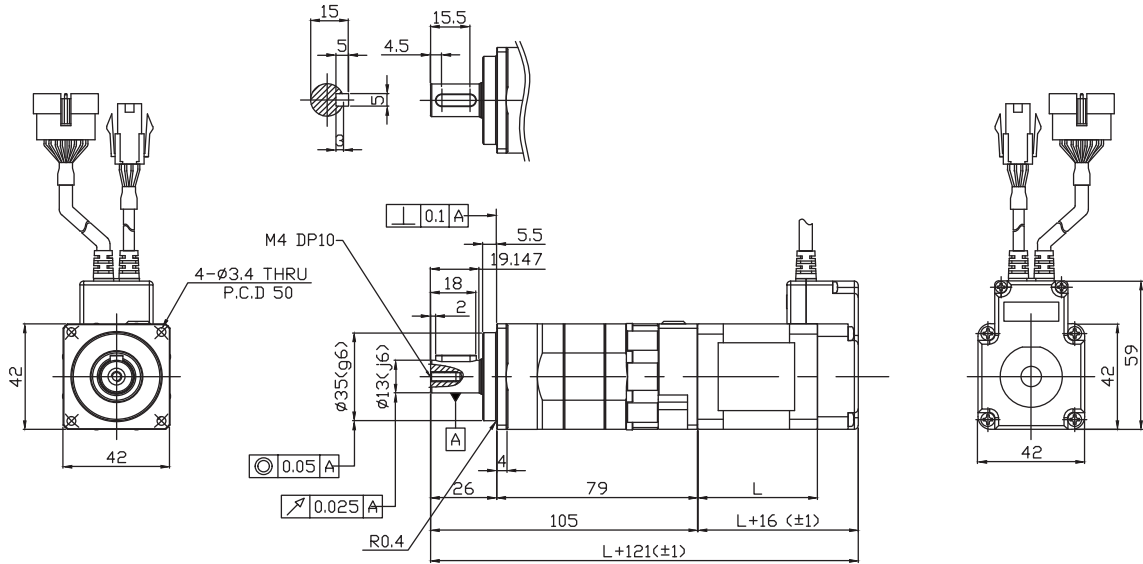

56

Model Name	Applied Motor Model Name	Stage	□Second Stage	L Length (mm)
S-SERVO-ST-56S-PG-PN□	SM-56S-PG-PN□	Single Stage	3, 5, 8, 10	41
S-SERVO-ST-56M-PG-PN□	SM-56M-PG-PN□		3, 5, 8, 10	56
S-SERVO-ST-56L-PG-PN□	SM-56L-PG-PN□		3, 5, 8, 10	76

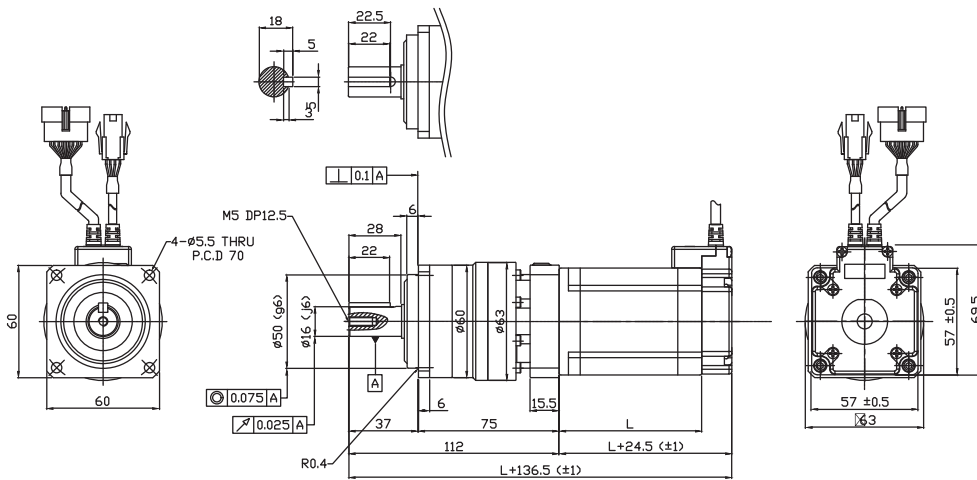

56

Model Name	Applied Motor Model Name	Stage	□Second Stage	L Length (mm)
S-SERVO-ST-56S-PG-PN□	SM-56S-PG-PN□	Second Stage	15, 25, 40, 50	41
S-SERVO-ST-56M-PG-PN□	SM-56M-PG-PN□		15, 25, 40, 50	56
S-SERVO-ST-56L-PG-PN□	SM-56L-PG-PN□		15, 25, 40, 50	76

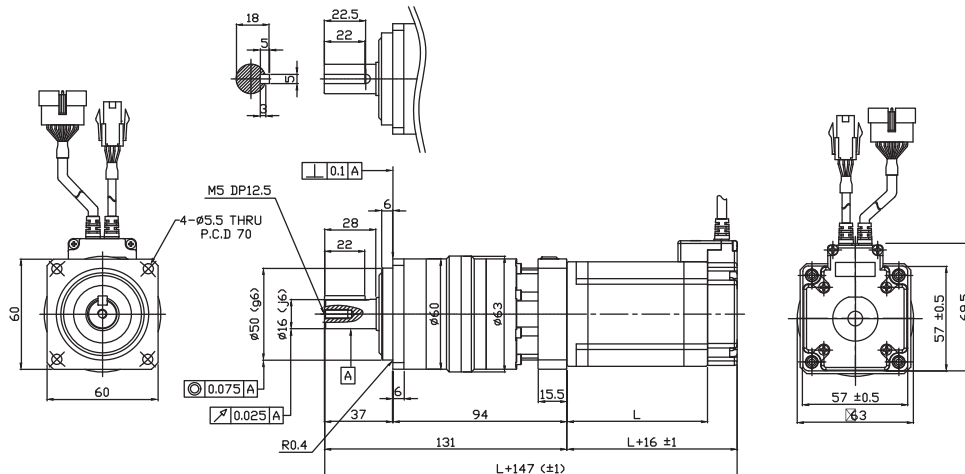

60

Model name	Applied Motor Model Name	Stage	□ Second Stage	L Length (mm)
S-SERVO-ST-60S-PG-PN□	SM-60S-PG-PN□	Single Stage	3, 5, 8, 10	46
S-SERVO-ST-60M-PG-PN□	SM-60M-PG-PN□		3, 5, 8, 10	56
S-SERVO-ST-60L-PG-PN□	SM-60L-PG-PN□		3, 5, 8, 10	85

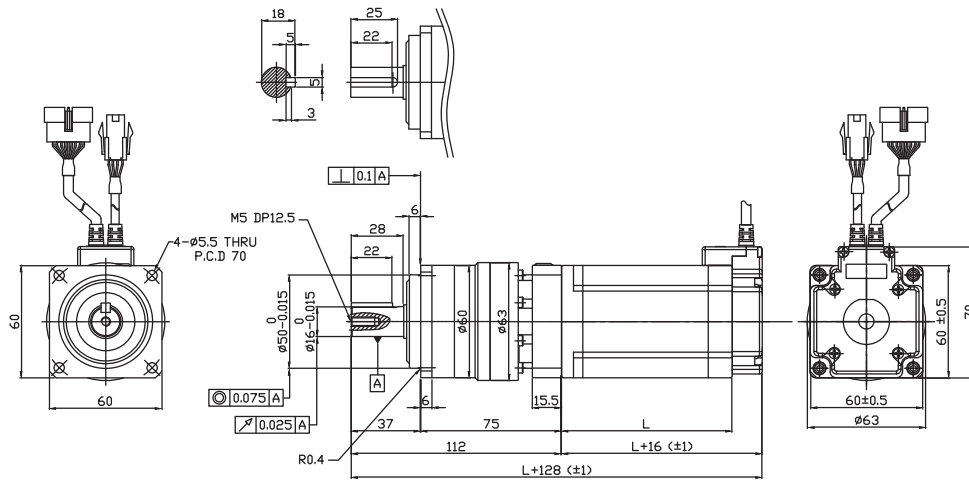

60

Model Name	Applied Motor Model Name	Stage	□ Second Stage	L Length (mm)
S-SERVO-ST-60S-PG-PN□	SM-60S-PG-PN□	Second Stage	15, 25, 40, 50	46
S-SERVO-ST-60M-PG-PN□	SM-60M-PG-PN□		15, 25, 40, 50	56
S-SERVO-ST-60L-PG-PN□	SM-60L-PG-PN□		15, 25, 40, 50	85

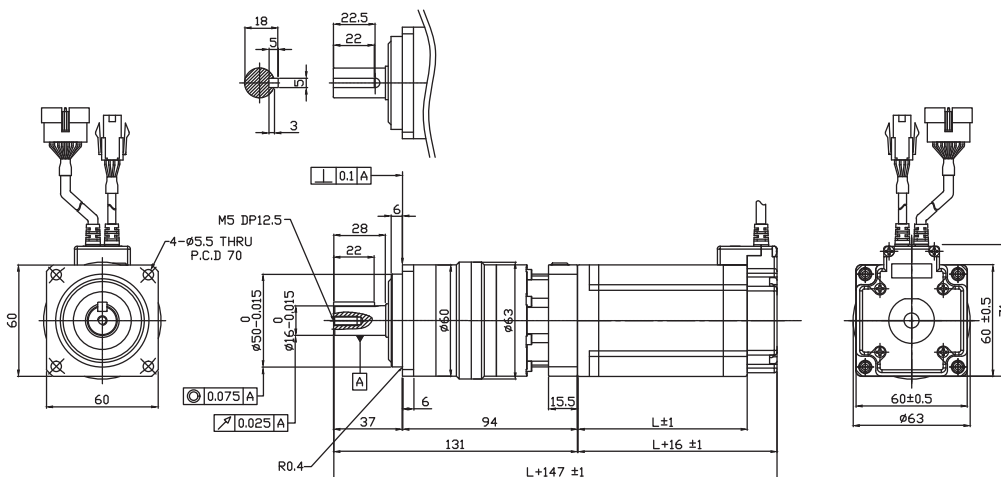

6. System Configuration

6.1 S-SERVO ST

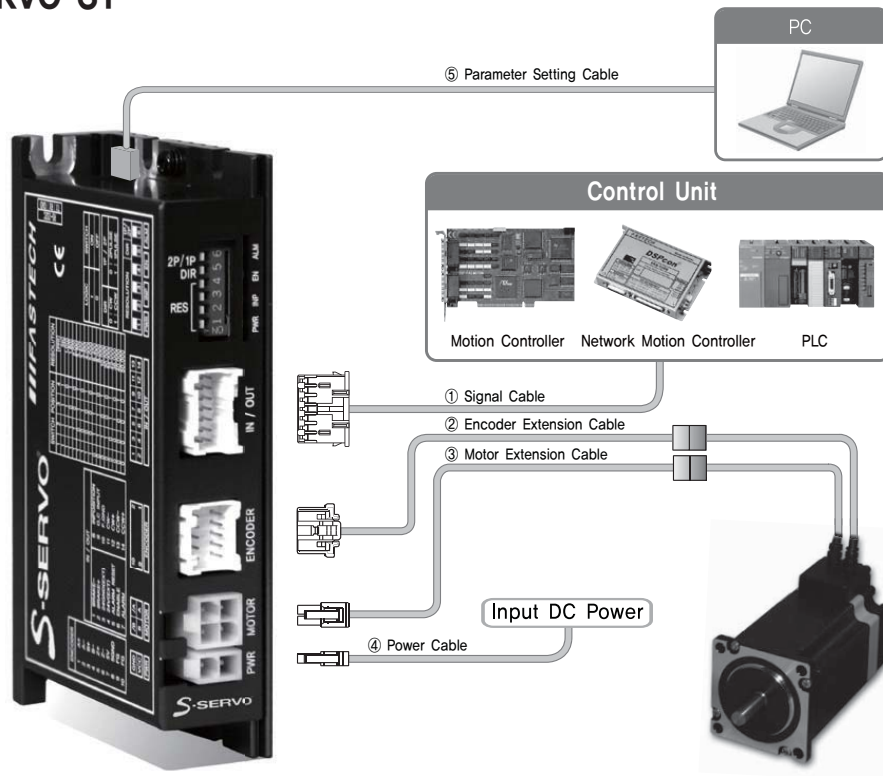

Type	Signal Cable	Encoder Cable	Motor Cable	Power Cable	Parameter Setting Cable
Standard Length	-	30cm	30cm	-	-
Max. Length	20m	20m	20m	2m	2m

Accessories [S-SERVO ST]

Purpose		ITEM	Standard	Quantity	Manufacturer
I/O Connections(CN1)		Housing	PADP-14V-1-S	1	JST
		Terminal	SPH-002T-P0,5L	16	
Encoder Connection	Drive Side(CN2)	Housing	51353-1000	1	MOLEX
		Terminal	56134-9000	12	
	Encoder Side	Housing	SMP-09V-NC	1	JST
		Terminal	SHF-001T-0,8BS	10	
Motor Connection	Drive Side(CN3)	Housing	5557-04R	1	MOLEX
		Terminal	5556T	5	
	Motor Side	Housing	5557-04R	1	
		Terminal	5556T	5	
Power Connection(CN4)		Housing	5557-02R	1	
		Terminal	5556T	3	

[S-SERVO ST] Cable Option

①Signal Cable

Model Name	Length(m)	Remark
CSSO-S-□□□F	□□□	Normal Cable
CSSO-S-□□□M	□□□	Robot Cable

□ is for Cable Length, The unit is 1m and Max. 20m Length.

Manufacturer : JST
Housing : PADP-14V-1-S
Terminal : SPH-002T-P0,5L

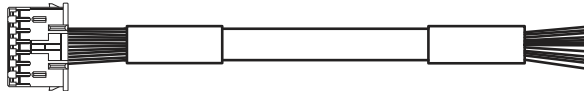

②Encoder Extension Cable

Model Name	Length(m)	Remark
CSVO-E-□□□F	□□□	Normal Cable
CSVO-E-□□□M	□□□	Robot Cable

□ is for Cable Length, The unit is 1m and Max. 20m Length.

Manufacturer : MOLEX
Housing : 51353-1000
Terminal : 56134-9000

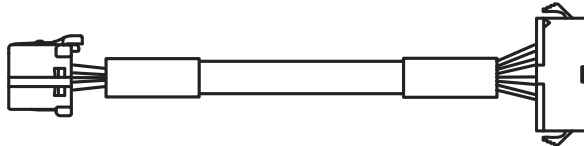

Manufacturer : JST
Housing : SMP-09V-NC
Terminal : SHF-001T-0,8BS

③Motor Extension Cable

Model Name	Length(m)	Remark
CSVO-M-□□□F	□□□	Normal Cable
CSVO-M-□□□M	□□□	Robot Cable

□ is for Cable Length, The unit is 1m and Max. 20m Length.

Manufacturer : MOLEX
Housing : 5557-04R
Terminal : 5556T

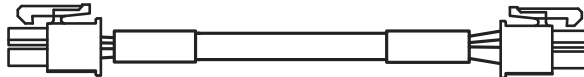

Manufacturer : MOLEX
Housing : 5557-04R
Terminal : 5556T

④Drive Power Cable

Model Name	Length(m)	Remark
CSVO-P-□□□F	□□□	Normal Cable
CSVO-P-□□□M	□□□	Robot Cable

□ is for Cable Length, The unit is 1m and Max. 2m Length.

Manufacturer : MOLEX
Housing : 5557-02R
Terminal : 5556T

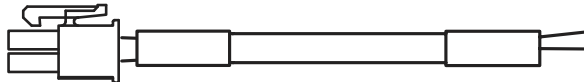

④Parameter Setting Cable

Model Name	Length(m)	Remark
CBTS-C-□□□F	□□□	Normal Cable

□ is for Cable Length, The unit is 1m and Max. 2m Length.

Manufacturer : MOLEX
Housing : 5264-03
Terminal : 5263

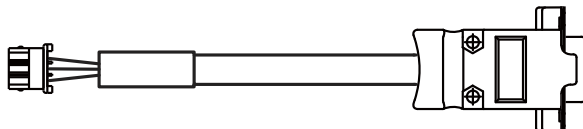

Manufacturer : AMPHENOL
Connector : L177SDE09S
Backshell : 17E-1657-09

6.2 S-SERVO MINI

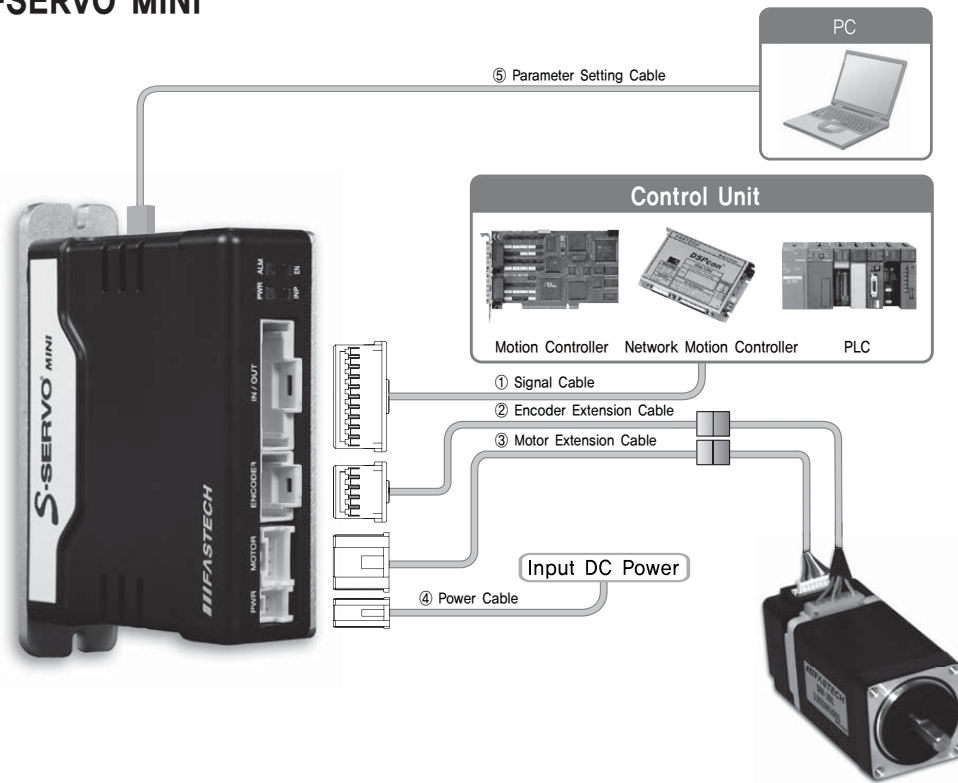

Type	Signal Cable	Encoder Cable	Motor Cable	Power Cable	Parameter Setting Cable
Standard Length	-	30cm	30cm	-	-
Max. Length	20m	20m	20m	2m	2m

Accessories [S-SERVO MINI]

Purpose		ITEM	Standard	Quantity	Manufacturer
I/O Connections(CN1)		Housing	501646-2000	1	MOLEX
		Terminal	501648-1000	23	
Encoder Connection	Drive Side(CN2)	Housing	501646-1000	1	MOLEX
		Terminal	501648-1000	12	
	Encoder Side	Housing	SMP-09V-NC	1	JST
		Terminal	SHF-001T-0,8BS	10	
Motor Connection	Drive Side(CN3)	Housing	PAP-04V-S	1	JST
		Terminal	SPHD-001T-P0,5	5	
	Motor Side	Housing	5557-04R	1	MOLEX
		Terminal	5556T	5	
Power Connection(CN4)		Housing	PAP-02V-S	1	JST
		Terminal	SPHD-001T-P0,5	3	

[S-SERVO MINI] Cable Option

①Signal Cable

Model Name	Length(m)	Remark
CSSM-S-□□□F	□□□	Normal Cable
CSSM-S-□□□M	□□□	Robot Cable

□ is for Cable Length, The unit is 1m and Max. 20m Length.

Manufacturer : MOLEX
Housing : 501646-2000
Terminal : 501648-1000

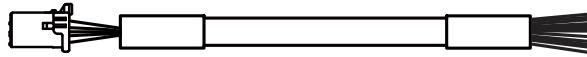

②Encoder Extension Cable

Model Name	Length(m)	Remark
CSVI-E-□□□F	□□□	Normal Cable
CSVI-E-□□□M	□□□	Robot Cable

□ is for Cable Length, The unit is 1m and Max. 20m Length.

Manufacturer : MOLEX
Housing : 501646-1000
Terminal : 501648-1000

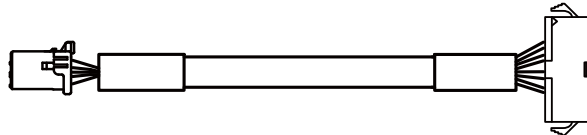

Manufacturer : JST
Housing : SMP-09V-NC
Terminal : SHF-001T-0,8BS

③Motor Extension Cable

Model Name	Length(m)	Remark
CMNB-M-□□□F	□□□	Normal Cable
CMNB-M-□□□M	□□□	Robot Cable

□ is for Cable Length, The unit is 1m and Max. 20m Length.

Manufacturer : JST
Housing : PAP-04V-S
Terminal : SPHD-001T-P0,5

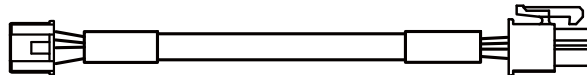

Manufacturer : MOLEX
Housing : 5557-04R
Terminal : 5556T

④Drive Power Cable

Model Name	Length(m)	Remark
CMNB-P-□□□F	□□□	Normal Cable
CMNB-P-□□□M	□□□	Robot Cable

□ is for Cable Length, The unit is 1m and Max. 2m Length.

Manufacturer : JST
Housing : PAP-02V-S
Terminal : SPHD-001T-P0,5



④Parameter Setting Cable

Model Name	Length(m)	Remark
CBTS-C-□□□F	□□□	Normal Cable

□ is for Cable Length, The unit is 1m and Max. 2m Length.

Manufacturer : MOLEX
Housing : 5264-03
Terminal : 5263

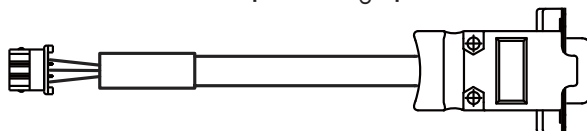

Manufacturer : AMPHENOL
Connector : L177SDE09S
Backshell : 17E-1657-09

7. Installation and Cabling

7.1 Installation Precautions

- 1) This unit is intended for indoor usage only.
- 2) Must be used under ambient temperature of 0°C~50°C.
- 3) When the temperature of the drive case is over 50°C the heat dissipation is required.
- 4) Should avoid from direct sunlight, magnetic or radioactive when install drive.
- 5) When connect I/O cable between host controller and drive, must turn off power of host controller and drive. Otherwise drive can be damaged.
- 6) Drive and motor should be grounded. To prevent the potential difference with surrounding control system device, it should be grounded directly to the ground point as short as possible.
- 7) When install two or more drives side-by-side, must be installed at a distance of at least 20mm at the horizontal direction and at a distance of at least 50mm at the vertical direction,

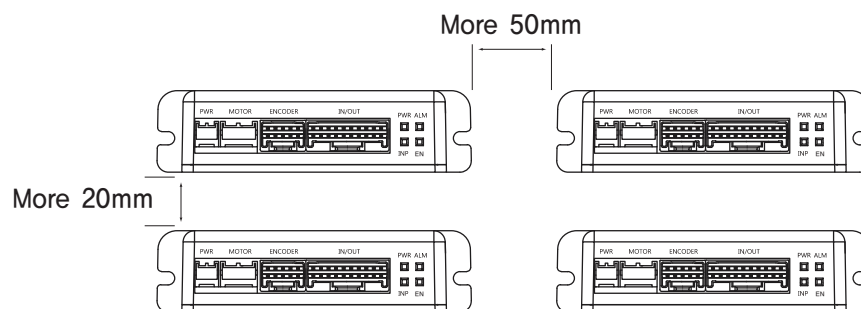
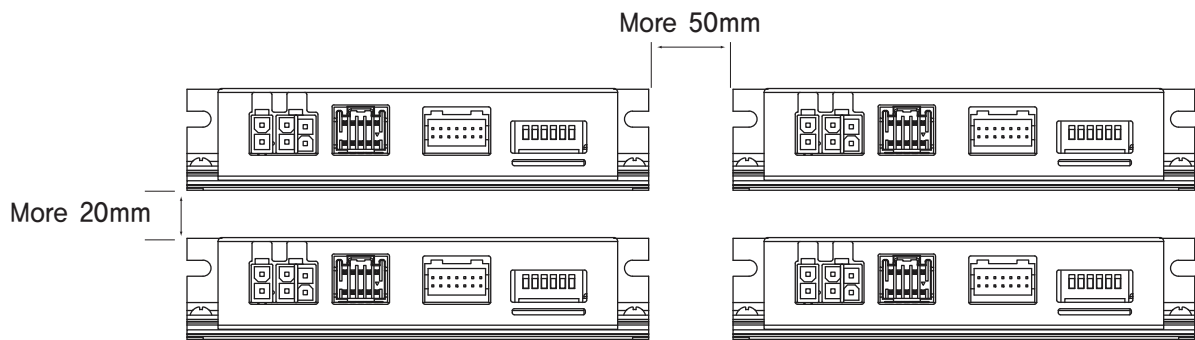

7.2 External Wiring Diagram

7.2.1 S-SERVO ST

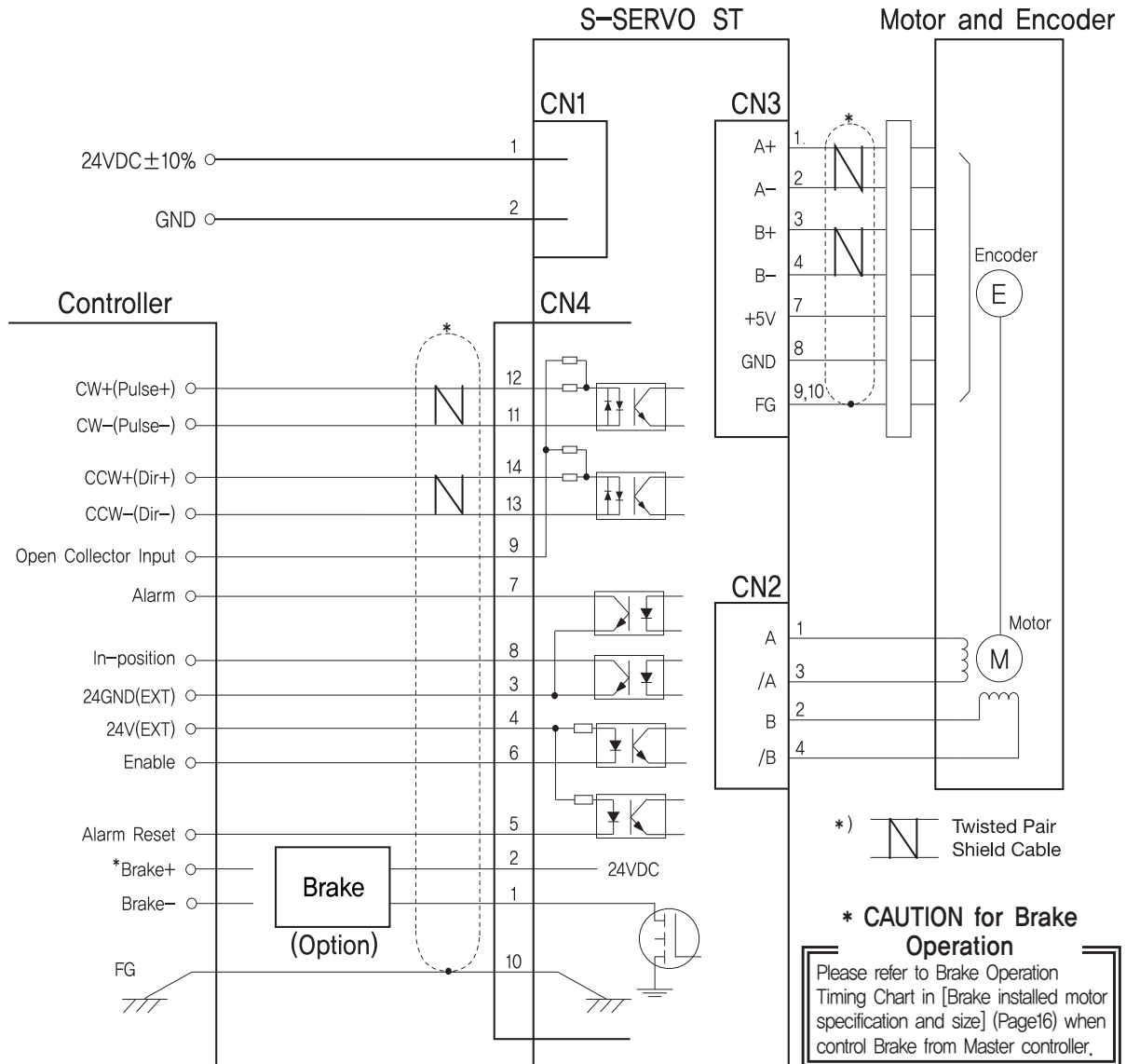

- * Turn power off of S-SERVO drive and master controller when connect I/O cable between drive and master controller to avoid any damage.
- * When the motor is installed on the movable parts, please use the flexible cable(Optional, sold separately). Otherwise, the cable can be disconnected.
- * I/O connection cable wiring to connect the drive and the host controller should be as short as possible. If longer, the maximum input frequency can be degraded or affected by noise cable.

7.2.2 S-SERVO MINI

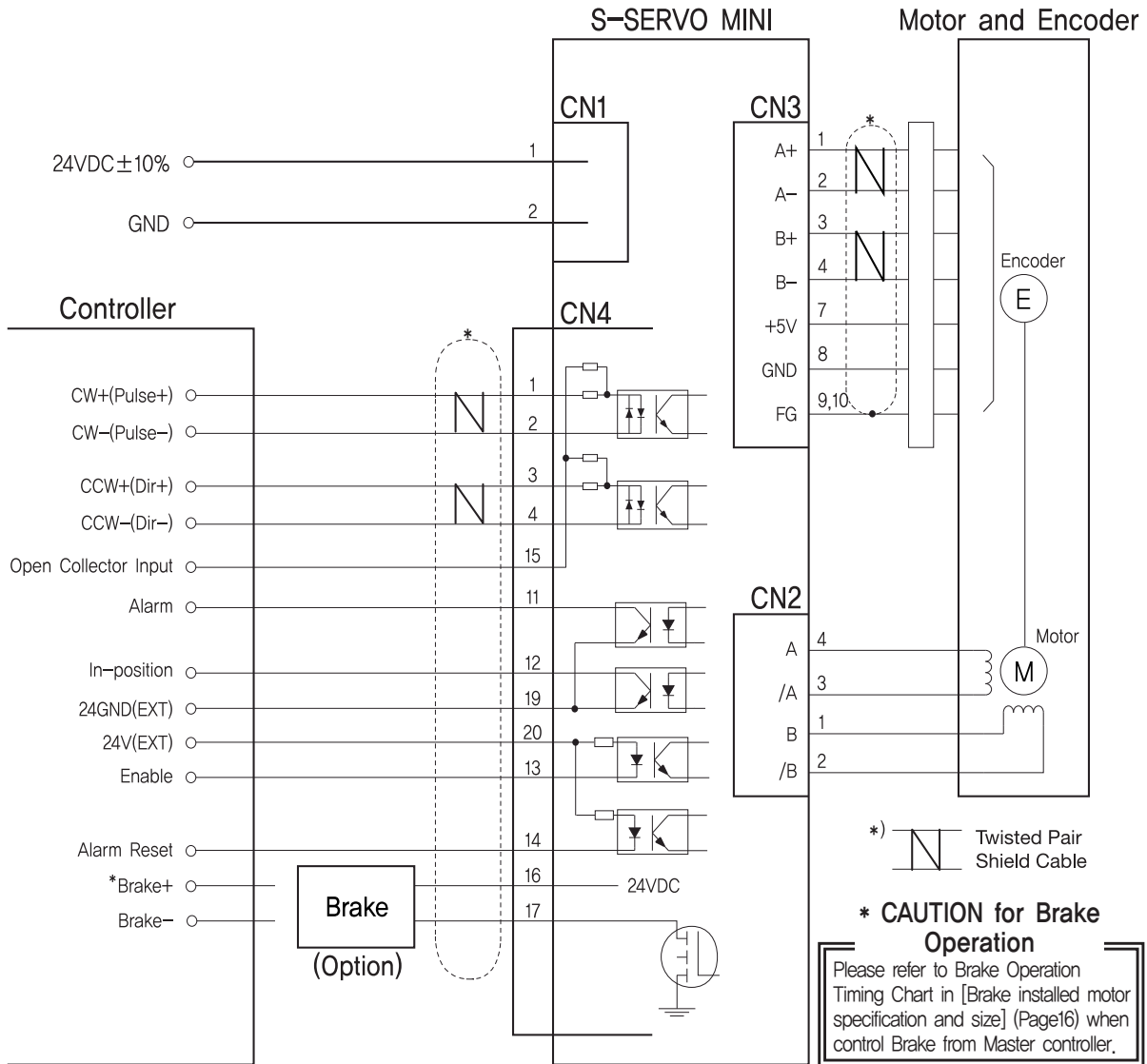

- * Turn power off of S-SERVO drive and master controller when connect I/O cable between drive and master controller to avoid any damage.
- * When the motor is installed on the movable parts, please use the flexible cable(Optional, sold separately). Otherwise, the cable can be disconnected.
- * I/O connection cable wiring to connect the drive and the host controller should be as short as possible. If longer, the maximum input frequency can be degraded or affected by noise cable.

8. Setting and Operation

8.1 S-SERVO ST

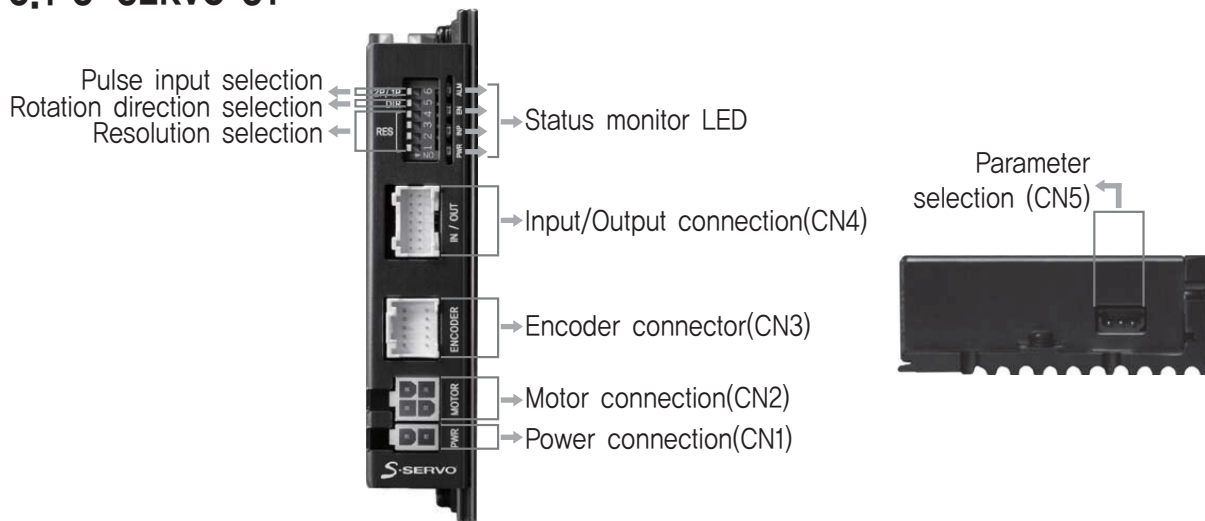

8.1.1 Status Monitor LED

Indication	Color	Function	ON/OFF Condition
PWR	Green	Power Input Indication	LED is turned ON when power is applied
INP	Yellow	Complete Positioning Motion	Light on when Position Deviation located within preset value* from target position, after Position Commando Pulse Input is completed
EN	Orange	Motor Enable Status	Enable : Lights On, Disable : Lights Off
ALM	Red	Alarm Indication	Flash when protection function is activated (Identifiable which protection mode is activated by counting the blinking times)

* Default = 0
Can be selected
by parameter
setting GUI

◆ Protection functions and LED flash times

Times	Protection	Conditions
1	Over Current Error	The current through power devices in inverter exceeds the limit value
2	Over Speed Error	Motor speed exceed 3,000rpm
3	Position Tracking Error	Position error value is higher than 90° in motor run state
4	Over Load Error	The motor is continuously operated more than 5 second under a load exceeding the max. torque
5	Over Temperature Error	Inside temperature of drive exceeds 85°C
6	Over Regenerated Voltage Error	Back-EMF more than 40V
7	Motor Connect Error	The power is ON without connection of the motor cable to drive
8	Encoder Connect Error	Cable connection error with Encoder connector in drive
9	Motor Voltage Error	Motor voltage less than 20V
10	In-Position Error	After operation is finished, a position error occurs
12	ROM Error	Error occurs in parameter storage device(ROM)
15	Position Overflow Error	Position error value is higher than 90° in motor stop state

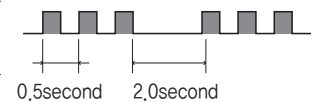

Alarm LED flash
(ex: Position tracking error)

8.1.2 Resolution Selection Switch(SW1.1~SW1.4)

The number of pulse per revolution.

Position(SW1)				Pulse/Revolution	Position(SW1)				Pulse/Revolution
1	2	3	4		1	2	3	4	
ON	ON	ON	ON	500	OFF	ON	ON	ON	6,400
ON	ON	ON	OFF	1,000	OFF	ON	ON	OFF	8,000
ON	ON	OFF	ON	1,600	OFF	ON	OFF	ON	10,000
ON	ON	OFF	OFF	2,000	OFF	ON	OFF	OFF	20,000
ON	OFF	ON	ON	3,200	OFF	OFF	ON	ON	25,000
ON	OFF	ON	OFF	3,600	OFF	OFF	ON	OFF	36,000
ON	OFF	OFF	ON	4,000	OFF	OFF	OFF	ON	40,000
ON	OFF	OFF	OFF	5,000	OFF	OFF	OFF	OFF	50,000

* Default = 10,000

8.1.3 Rotational Direction Selection Switch(SW1.5)

Indication	Switch Name	Functions
DIR	Switching Rotational Direction	Based on CW(+Dir signal) input to driver. ON : CCW(-Direction) OFF : CW(+Direction) * Default : CW mode

Direction selection switch : ON

CCW Dir.

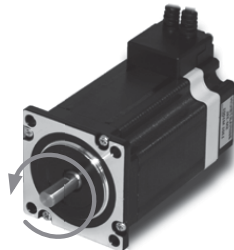

Direction selection switch : OFF

CW Dir.



8.1.4 Pulse Input Selection Switch(SW1.6)

Indication	Switch Name	Functions
2P/1P	Selecting Pulse Input Mode	Selectable 1-Pulse input mode or 2-Pulse input mode as Pulse input signal. ON : 1-Pulse mode OFF : 2-Pulse mode * Default : 2-Pulse mode

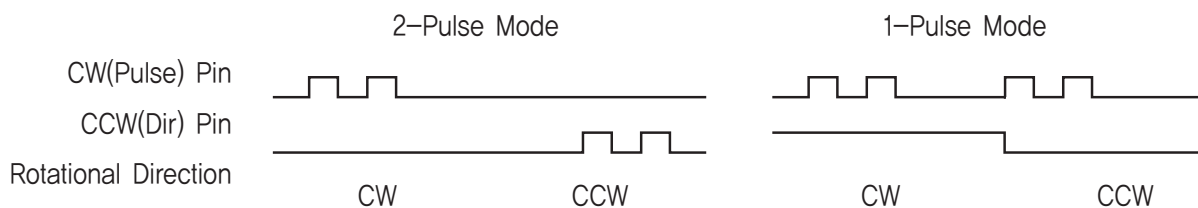

8.1.5 Power Connector(CN1)

NO.	Function
1	24VDC \pm 10%
2	GND

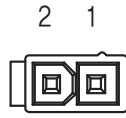

8.1.6 Motor Connector(CN2)

NO.	Function
1	A Phase
2	B Phase
3	/A Phase
4	/B Phase

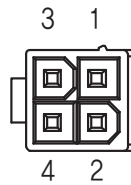

8.1.7 Encoder Connector(CN3)

NO.	Function	I/O
1	A+	Input
2	A-	Input
3	B+	Input
4	B-	Input
5	NC	----
6	NC	----
7	5VDC	Output
8	5GND	Output
9	F. GND	----
10	F. GND	----

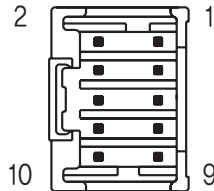

8.1.8 Input/Output Signal(CN4)

NO.	Function	I/O
1	Brake-	Output
2	Brake+	Output
3	24GND(EXT)	Input
4	24V(EXT)	Input
5	Alarm Reset	Input
6	Enable	Input
7	Alarm	Output
8	In-Position	Output
9	Open Collector Input	Input
10	F.GND	----
11	CW-(Pulse-)	Input
12	CW+(Pulse+)	Input
13	CCW-(Dir-)	Input
14	CCW+(Dir+)	Input

* Brake is optional.

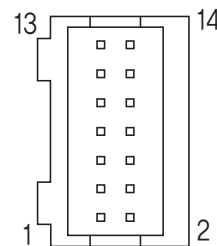

8.1.9 Parameter Connector(CN5)

NO.	Function	I/O
1	TX	Output
2	RX	Input
3	GND	----

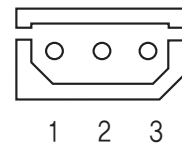

8.2 S-SERVO MINI

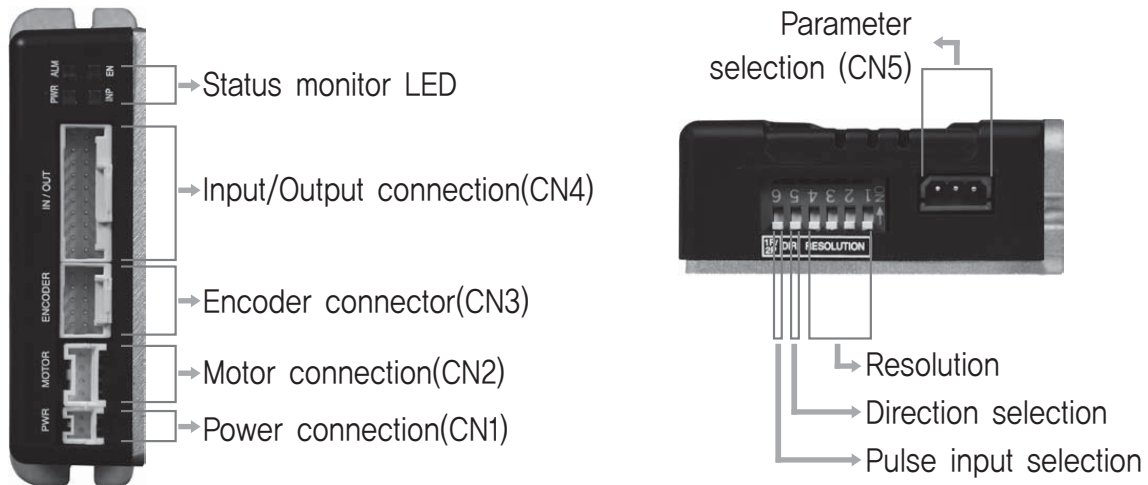

8.1.1 Status Monitor LED

Indication	Color	Function	ON/OFF Condition
PWR	Green	Power Input Indication	LED is turned ON when power is applied
INP	Yellow	Complete Positioning Motion	Light on when Position Deviation located within preset value* from target position, after Position Commando Pulse Input is completed
EN	Orange	Motor Enable Status	Enable : Lights On, Disable : Lights Off
ALM	Red	Alarm Indication	Flash when protection function is activated (Identifiable which protection mode is activated by counting the blinking times)

* Default = 0
Can be selected by parameter setting GUI

◆ Protection functions and LED flash times

Times	Protection	Conditions
1	Over Current Error	The current through power devices in inverter exceeds the limit value
2	Over Speed Error	Motor speed exceed 3,000rpm
3	Position Tracking Error	Position error value is higher than 90 ° in motor run state
4	Over Load Error	The motor is continuously operated more than 5 second under a load exceeding the max. torque
5	Over Temperature Error	Inside temperature of drive exceeds 85°C
6	Over Regeneratived Voltage Error	Back-EMF more than 40V
7	Motor Connect Error	The power is ON without connection of the motor cable to drive
8	Encoder Connect Error	Cable connection error with Encoder connector in drive
9	Motor Voltage Error	Motor voltage less than 20V
10	In-Position Error	After operation is finished, a position error occurs
12	ROM Error	Error occurs in parameter storage device(ROM)
15	Position Overflow Error	Position error value is higher than 90 ° in motor stop state

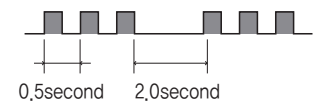

Alarm LED flash
(ex: Position tracking error)

8.2.2 Resolution Selection Switch(SW1.1~SW1.4)

The number of pulse per revolution.

Position(SW1)				Pulse/Revolution	Position(SW1)				Pulse/Revolution
1	2	3	4		1	2	3	4	
ON	ON	ON	ON	500	OFF	ON	ON	ON	6,400
ON	ON	ON	OFF	1,000	OFF	ON	ON	OFF	8,000
ON	ON	OFF	ON	1,600	OFF	ON	OFF	ON	10,000
ON	ON	OFF	OFF	2,000	OFF	ON	OFF	OFF	20,000
ON	OFF	ON	ON	3,200	OFF	OFF	ON	ON	25,000
ON	OFF	ON	OFF	3,600	OFF	OFF	ON	OFF	36,000
ON	OFF	OFF	ON	4,000	OFF	OFF	OFF	ON	40,000
ON	OFF	OFF	OFF	5,000	OFF	OFF	OFF	OFF	50,000

* Default = 10,000

8.2.3 Rotational Direction Selection Switch(SW1.5)

Indication	Switch Name	Functions
DIR	Switching Rotational Direction	Based on CW(+Dir signal) input to driver. ON : CCW(-Direction) OFF : CW(+Direction) * Default : CW mode

Direction selection switch : ON

CCW Dir.



Direction selection switch : OFF

CW Dir.



8.2.4 Pulse Input Selection Switch(SW1.6)

Indication	Switch Name	Functions
2P/1P	Selecting Pulse Input Mode	Selectable 1-Pulse input mode or 2-Pulse input mode as Pulse input signal. ON : 1-Pulse mode OFF : 2-Pulse mode * Default : 2-Pulse mode

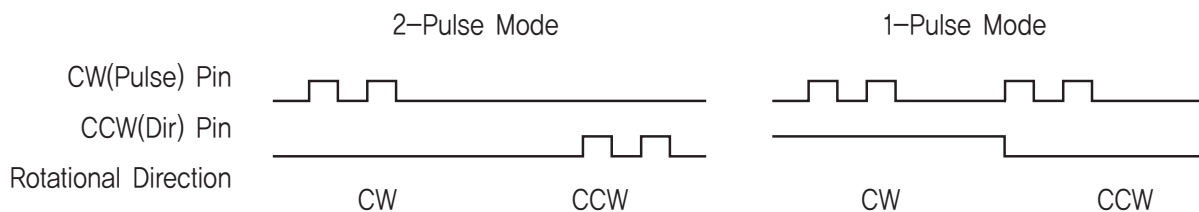

8.2.5 Power Connector(CN1)

NO.	Function
1	24VDC \pm 10%
2	GND

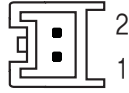

8.2.6 Motor Connector(CN2)

NO.	Function
1	B Phase
2	/B Phase
3	/A Phase
4	A Phase

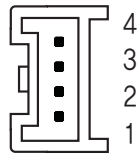

8.1.7 Encoder Connector(CN3)

NO.	Function	I/O
1	A+	Input
2	A-	Input
3	B+	Input
4	B-	Input
5	NC	---
6	NC	---
7	5VDC	Output
8	5GND	Output
9	F. GND	---
10	F. GND	---

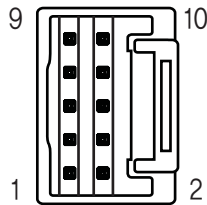

8.2.8 Input/Output Signal(CN4)

NO.	Function	I/O
1	CW+(Pulse+)	Input
2	CW-(Pulse-)	Input
3	CCW+(Dir+)	Input
4	CCW-(Dir-)	Input
5	NC	---
6	NC	---
7	NC	---
8	NC	---
9	NC	---
10	NC	---
11	Alarm	Output
12	In-Position	Output
13	Enable	Input
14	Alarm Reset	Input
15	Open Collector Input	Input
16	Brake+	Output
17	Brake-	Output
18	NC	---
19	24GND(EXT)	Input
20	24V(EXT)	Input

* Brake is optional.

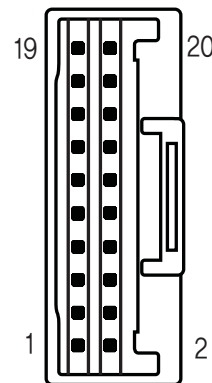

8.2.9 Parameter Connector(CN5)

NO.	Function	I/O
1	TX	Output
2	RX	Input
3	GND	---

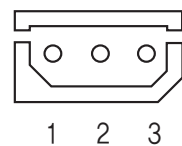

9. Input and Output Signals

9.1 Input Signal

Input signals of the drive are all photocoupler protected. The signal shows the status of internal photocouplers [ON: conduction], [OFF: Non-conduction], not displaying the voltage levels of the signal.

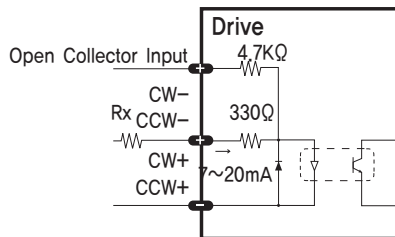

Functions	Pin Number	
	S-SERVO ST	S-SERVO MINI
Open Collector Input	9	15
CW+	12	1
CW-	11	2
CCW+	14	3
CCW-	13	4

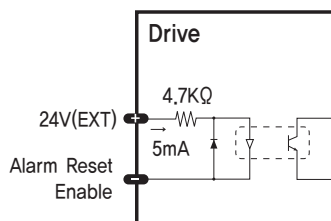

Functions	Pin Number	
	S-SERVO ST	S-SERVO MINI
24V(EXT)	4	20
Alarm Reset	5	14
Enable	6	13

◆ CW, CCW Input

This signal can be used to receive a positioning pulse command from a user host motion controller. The user can select 1-pulse input mode or 2-pulse input mode (refer to switch No.1, SW1).

The input schematic of CW, CCW is designed for 5V TTL level. When using 5V level as an input signal, the resistor Rx is not used and connect to the driver directly. When the level of input signal is more than 5V, Rx resistor is required. If the resistor is absent, the drive will be damaged! If the input signal level is 12V, Rx value is 680ohm and 24V, Please use Open Collector Input.

◆ Enable Input

This input can be used only to adjust the position by manually moving the motor shaft from the load-side. By setting the signal [ON], the driver cuts off the power supply to the motor. Then, one can manually adjust output position. When setting the signal back to [OFF], the driver resumes the power to the motor and recovers the holding torque. When driving a motor, one needs to set the signal [OFF].

◆ Alarm Reset Input

When a protection mode has been activated, a signal to this alarm reset input cancels the Alarm output.

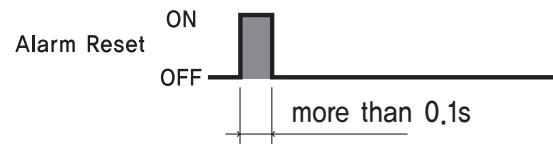

* By setting the alarm reset input signal [ON], cancel the Alarm output. Before cancel the Alarm output, have to remove the source of alarm.

9.2 Output Signals

Output signals from the driver are photocoupler protected: Alarm, In-Position. The signal indicates the status of internal photocouplers [ON: conduction], [OFF: Non-conduction], not displaying the voltage levels of the signal.

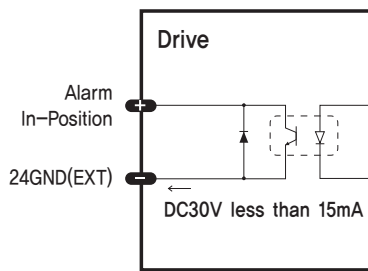

Functions	Pin Number	
	S-SERVO ST	S-SERVO MINI
Alarm	7	11
In-Position	8	12
24GND(EXT)	3	19

◆ In-Position Output

In-Position signal is [ON] when positioning is completed. This signal is [ON] when the motor position error is within the value set by the switch SW4.

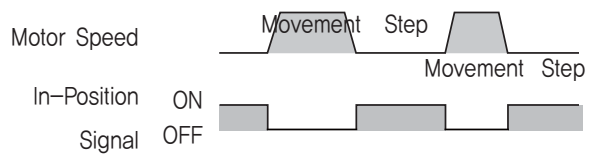

◆ Alarm Output

The Alarm output indicates [ON] when the driver is in normal operation. If a protection mode has been activated, it goes [OFF]. A host controller needs to detect this signal and stop sending a motor driving command. When the driver detects an abnormal operation such as overload or over current of the motor, it sets the Alarm output to [OFF], flashes the Alarm LED, disconnect the power to a motor and stops the motor simultaneously.

[Caution] Only at the Alarm output port, the photocoupler isolation is in reverse. When the driver is in normal operation the Alarm output is [ON]. On the contrary when the driver is in abnormal operation that start protection mode, the Alarm output is [OFF].

10. Diagnosis and Rectification of Faults

10.1 When the Alarm LED is not Blinking

Even though the alarm LED is not blinking if the motor can not be operated as normal, please refer to below chart.

Phenomenon	Possible Cause	Rectification
Motor axis can be moved by hand	Enable input is [ON].	When Alarm LED(RED) does not blink and EN LED(Orange) is turned off, this is not a state of Motor Enable. Please check signal of Controller.
Motor axis can not be moved by hand	Bad connection of input terminal.	Please check connection between Controller and Drive.
	When Pulse Mode of Drive is CW/CCW input method (2Pulse input method), CW+ line and CW- line may have been reversed or CCW+ line and CCW- line may have been reversed.	Please check connection status of CW+, CW-, CCW+ and CCW- lines.
	The brake is locked. (Only for brake installed type)	Please loosening the brake by energized.
Motor shaft moves only one direction	Pulse Mode of Drive is set as CW/CCW input method (2Pulse input method), then Controller send Pulse by CW/CCW method(1Pulse method).	Please check signal method of Controller.
	Pulse Mode of Drive is set as Pulse/Dir input method(1Pulse input method), then Controller send Pulse by Pulse/Dir method(2Pulse method).	Please check signal method of Controller.
Motor axis moves in the opposite direction to the specified direction	When Pulse Mode of Drive is CW/CCW input method (2Pulse input method), CW input and CCW input is connected reversely.	The CW Pulse signal should be connected to CW input, CCW Pulse signal should be connected to CCW input.
	When Pulse Mode of Drive is CW/CCW input method (2Pulse input method), setting of Motion Direction is set reversely.	Please check switch of rotation direction (SW 1.5)
	When Pulse Mode of Drive is Pulse/Dir input method (1Pulse input method), setting of Motion Direction is set reversely.	Please check switch of rotation direction (SW 1.5)
	When Pulse Mode of Drive is Pulse/Dir input method (1Pulse input method), CCW+(Dir+) line and CCW-(Dir-) may have been reversed.	Please check connection status of CCW+(Dir+), CCW-(Dir-) lines.
Motion of motor is unstable	Bad connection of Pulse signal cable	Please check connection of Controller and Drive.
No retention of the brake	The brake is released. (Only for brake installed type)	Please stop the power supply to brake, so keep the locked state of brake.
Motor axis movement does not match to the set amount	The setting of resolution is difference.	Please check setting switch of resolution (SW1.1~4)

10.2 When the Alarm LED is Blinking

When Alarm LED of drive is blinking, the protection function is generated. Please count the number of blinking and refer to chart below. The Alarm LED is blinking 1 to 15 times (0.5 seconds on, 0.5 seconds off), the same number of blinking will be repeated after 2 seconds.

Flash Times	Alarm Contents	Conditions	The Cause of Error	Checking Point	Corrective Measure
1	Over Current	The current through motor-driven devices exceeds the limit value	If motor has a problem	Checking the status of the short-circuit of the motor cable. (A and/A, B and B, A or /A and motor body, B or /B and Motor body)	① Replace the motor.
			If drive has a problem		① If Alarm keep blinking after replace the motor, replace drive.
2	Over Speed	Motor speed exceed 3,000rpm	The host controller like PLC send speed command of over 3,000rpm	Checking speed command of host controller (PLC)	① Lower the speed command of the host controller.
3	Position Tracking Error	Position error value is higher than 90° in motor run state	The rotation of motor is not smooth because of mechanical problem	Checking the assemble status of the unit(unscrews, debris, and deformation structures)	① Fix the defected structure of the equipment.
			Operate brake when it is locked	Checking the brake cable by brake operation sound. Checking if 24V is supplied to No.2(ST) and No.16(MINI) terminal of I/O connector. Checking the terminal signal of No.1(ST) and No.17(MINI) of I/O connector. If brake hold it self, it means 24V, if not it is 0v.	① Fix the defect of brake. ② If brake control signal is correct, replace the brake.
			Motor does not operate because motor is damaged	Checking if the motor bearing is damaged. → Power off the motor, and listening to sound while rotate shaft of motor by hand. Checking a short circuit and disconnection of motor cable. → Checking a short circuit and disconnection by multimeter.	① Replace the motor when bearing is damaged, disconnection of motor cable and short circuit.
			Motor does not operate because encoder is damaged	Checking the connection status of encoder cable, → Checking short circuit, disconnection, faulty wiring of cable.	① Correct the mis-wiring. ② Replace the cable when cable is disconnected. ③ Correct the short circuit.
			Motor does not operate because of transient shock to mechanical part	Cause of Shock elimination	① Remove the cause of the shock.
			If drive has a problem		② If Alarm keep blinking after tried all of above, replace the drive.

Flash Times	Alarm Contents	Conditions	The Cause of Error	Checking Point	Corrective Measure
4	Over Load	The motor is continuously operated more than 5second under a load exceeding the max torque	If send the command to move into the distance beyond the end of the structure	Checking the command of distance from host controller(PLC).	① Fix the command of distance to reasonable value.
			It does not operate normally, because its deformable structure	Checking the assemble status of the equipment. (Unscrews, debris, and deformation structures)	① Fix the assemble status of the equipment.
			It reaches end of structure because S/W Limit value is not set	Checking the S/W Limit value.	① Fix the S/W Limit value to suit to the equipment.
			It reached end of structure because sensor of H/W Limit is not operated	Checking whether H/W Limit sensor working correctly.	① Replace the H/W Limit sensor.
			The load exceeding the Max torque of motor	Checking whether motor has enough torque by comparing to load of instrument.	① Lower the speed of operation. (Step motor generate higher torque when speed is low) ② When ① is impossible, replace the motor to higher torque than load.
			Motor does not operate because motor is damaged	Checking whether motor is damaged because motor bearing damage. → Power off the motor, and listening to sound while rotate shaft of motor by hand.	① If find any damage, replace the motor.
			The drive may have problem		① If Alarm keep blinking after tried all of above, replace the drive.
5	Over Temperature	Inside temperature of drive exceeds 65℃	If the ambient temperature is too high or the heating element is near the drive	Checking the ambient temperature and make sure no heating element near the drive.	① Lower the room ambient temperature to under 25℃, and do heat dissipation by fan when the temperature of the case is over 50℃ ② Remove the heating element from the drive.
			Distance between drive is below 50mm, so heat dissipation is difficult	Make sure the distance between drive is more than 50mm.	① Keeping the distance more than 50mm between drive. ② If ① is impossible, do heat dissipation by FAN.
			The drive may have problem		③ If Alarm keep blinking after tried all of above, replace the drive.
6	Over Regenerative Voltage	Back-EMF of motor exceeds 40V	The acceleration and deceleration value is too small	Checking the Acceleration and Deceleration conditions. (Difference depending on load and speed)	① Change the condition of Acceleration and Deceleration. ② Lower the operation speed of motor relatively.
			The drive may have problem		① If Alarm keep blinking after tried all of above, replace the drive.

Flash Times	Alarm Contents	Conditions	The Cause of Error	Checking Point	Corrective Measure
7	Motor Connect Error	An error with the connection between the drive and the motor	The motor may have problem	Checking the disconnection of motor phase. (A and/A, B and/B)	① Replace the motor.
			If the motor cable between motor and drive is damaged	Checking the connection of the motor cable.	① Fix the error after check connection status of motor cable. ② Replace the extension cable between motor and drive, if there is problem.
			The drive may have problem		① If Alarm keep blinking after tried all of above, replace the drive.
8	Encoder Connect Error	An error with the connection between the drive and the encoder	If the encoder extension cable is damaged	Checking the connection status of motor and the extension cable of encoder.	① Make sure connection of cable connector.
				Checking if the extension cable of encoder is disconnected.	① Replace the extension cable of encoder.
				Checking the wiring status of the extension cable of encoder.	① Fix the extension cable of encoder. ② If same alarm is generated after correction, drive and motor may have damaged by faulty cable, so replace the motor and drive.
			The encoder may have problem	Checking if the encoder is damaged, unscrew or extension cable of encoder is disconnected. (Can not be checked when assembled)	① Replace the motor.
			The drive may have problem		① If Alarm keep blinking after tried all of above, replace the drive.
9	Motor Voltage Error	Motor supply voltage is lower than 20V	The voltage of power supply device is lower than 24V	Checking whether voltage of power supply device is 24V.	① If voltage of power supply is not 24V, disconnect drive and power supply and checking the voltage of power supply. If not reach 24V, adjust the voltage to 24V. ② If voltage of power supply can not adjusted as 24V, replace the power supply.
			The voltage input to the drive is lower than 24V	Checking the length and thickness of power cable of power supply to the motor.	① If not using standard cable, replace it to standard cable. ② If length of cable is too long, shorten it. ③ If ① and ② is impossible, adjust voltage of SMPS to make sure measured voltage of drive side will be bigger than 24V.
			The drive may have problem		① If Alarm keep blinking after tried all of above, replace the drive.

Flash Times	Alarm Contents	Conditions	The Cause of Error	Checking Point	Corrective Measure
10	In-Position Error	After operation is finished, a position error(more than 1) occur for more than 3seconds	The mechanical part is in vibration status	Checking the status of vibration of mechanical part by hand.	① Remove the cause of vibration.
			The tension of pulley is not suitable if the pulley is applied	Checking the tension of the pulley.	① Adjust to suitable tension by tension gage.
			After Enable, motor does not grab the STEP degree by external force	Checking whether mechanical part not moving due to external force.	① Reassemble the mechanical part.
			The wiring of extension cable of motor and encoder is not correct	Checking the wiring status of extension cable of motor and encoder.	① Fix the wiring of the cable.
			The motor may have problem	Checking the status of the short-circuit or disconnection of the motor cable. (A and/A, B and B, A or /A and motor body, B or /B and Motor body)	① Replace the motor.
			The drive may have problem		① If Alarm keep blinking after tried all of above, replace the drive.
12	ROM Error	The ROM may have problem	The parameter Storage Devices(ROM) in the motor controller may have problem	Checking whether any problem with power. Make sure voltage of drive input terminal is over 23V.	① If power is correct, turn off and turn it back on. If alarm keep blinking after tried above, replace the drive.
15	Position Overflow Error	Position error value is higher than 90° in motor stop status.	The motor is rotated by external force	Checking whether external force generate motor rotation.	① Remove the external force. ② If ① is impossible, install the brake so motor does not rotate when it stopped. ③ ① and ② are impossible, replace the motor, so can have higher holding torque bearable to external force.
			The brake may have problem	Checking the operation status of brake.	① Replace the brake. ② If motor rotate when brake is working well, it means external force exceeds power of brake. Replace the brake to have higher torque.
			The encoder may have problem	Checking the install status of encoder and the output signal.	① Replace the motor.
			The drive may have problem		① If alarm is keep generated, after tried all of above, replace the drive.

11. Parameter Setting GUI [User Interface]

S-SERVO ST driver using many parameters to do operation.

Some parameters need to be changed when user feel inconvenience to use or in purpose of maximize the efficiency.

S-SERVO ST provides parameter modify program for convenience of user.

The screen shot in the below is computer program (GUI) which used for operation process. User can change the parameter of drive to Enable level, Alarm reset level, Imposition level, Alarm output level. User can use S-SERVO ST according to their system.

Please connect parameter setting GUI when S-SERVO is Disable state.

For safety reason, S-SERVO can not be connected to setting GUI when it is Enable state.

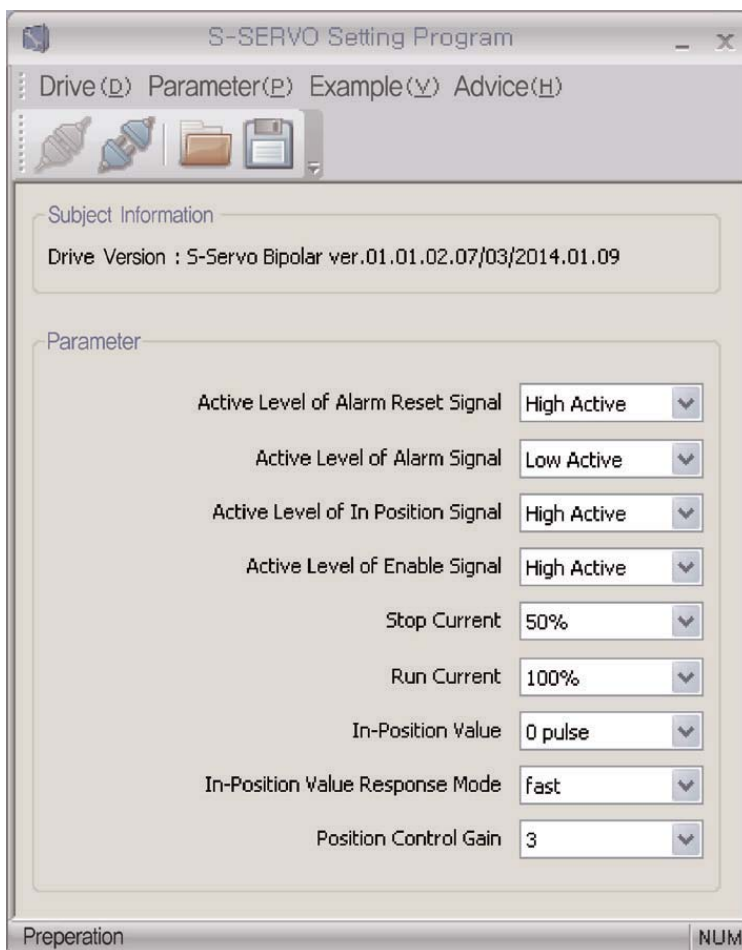

- * Parameter setting program (GUI) can be downloaded from website (www.fastech.co.kr).
- * Parameter setting program (GUI) support Windows XP, VISIA, 7,8 (32,64bit).
- * Parameter setting program (GUI) can be updated without warning to increase performance and convenience of user.

The content below is a description of the function for the parameter. Please refer to the attached sheet when set the parameters. The input and output terminal of drive are all photocoupler. The signal shows the status of internal photocouplers [ON: conduction], [OFF: Non-conduction], not displaying the voltage levels of the signal.

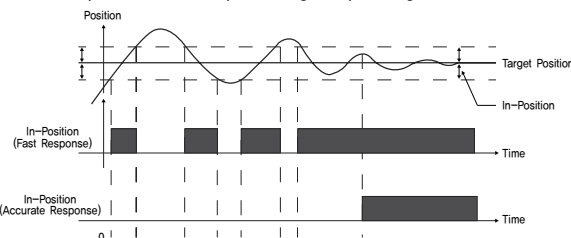
Parameters	The Initial Value	Range	Function
Active Level of Alarm Reset Signal	High	Low, High	Set the level of input signal of Alarm Reset. When set it to High and input of Alarm Reset is [ON], the Alarm output will be offed.
Active Level of Alarm Signal	Low	Low, High	Set the level of output signal of Alarm Reset. When set it to Low, the Alarm output is [ON] when normal state, and the Alarm output is [OFF] when protection function is operated.
Active Level of In-Position Signal	High	Low, High	Set the level of output signal of In-Position. When set it to High, In-Position output after completion of motor movement, output become [ON]
Active Level of Enable Signal	High	Low, High	Set the level of input signal of Enable input. When set it to High, if Enable input is [ON], drive will stop to power supply to the motor.
Stop Current	50%	20%~100%	Stop Current means motor current which is set automatically after 0.1 seconds of motor is stopped. This parameter is used for reduce the temperature when the motor is stopped for a long time. The motor temperature can rises If set the Stop Current more than 60%.
Run Current	100%	50%~150%	Run Current is value of the current through the motor, while motor is operating (rotating), and it is set based on Rated Current of the motor. Run Current value is related to torque while motor is operating (rotating). If Run Current value is high, torque value also become higher while motor is operating (rotating). Therefore, if it is determined as lack of torque while motor is operating (rotating), torque value while motor is operating (rotating) can be raised by increasing the value of Run Current Parameter. Warning) 1) If Run Current value is high, also the motor temperature can be increased, so please be aware. 2) The maximum setting value (150%) of Run Current is limited to the 4A. Therefore, if rated current value of motor exceeds 2.7A (55mm, 60mm), Run Current value cannot be increased by raise the Run Current value. 3) In case of S-SERVO, Run Current is automatically adjusted according to the load. Therefore, please raise the Run Current only in case of lack of operating torque.
In-Position Value	0pulse	0~63pulse	It shows output conditions of positioning complete signal. In-Position output signal is generated when the pulse number of positional error is lower than selected In-position value set by this switch after positioning command is executed.
In-Position Value Response Mode	Fast	Fast, Accurate	It shows output conditions of positioning complete signal. 
Position Control Gain	3	0~63	When the motor is stopping, it is used to adjust the response of motor according to load mounted on the motor. This value is not the actual value that used inside of drive, it is relative value. For example, if the value is changed from 3 to 6, it does not mean response time will be doubled. If value of this parameter is small, the motion of stopping of motor is become sensitive, and takes less time to stop. If value of this parameter is large, the motion of stopping of motor is become insensitive, and takes more time to stop. In the normal conditions, use the factory default value. Especially, if the load of inertia moment is greater than the motor so motor cannot stop normally, normal operation is possible by increasing the value of this parameter.

▪ **Memo**

▪ **Memo**



Fast, Accurate, Smooth Motion

FASTECH Co., Ltd.

Rm #1202, Bucheon Technopark 401 Dong, Yakdea-dong,
Wonmi-Gu, Bucheon-si, Gyeonggi-do, Rep. Of Korea (Zip)420-734
TEL : 82-32-234-6300,6301 FAX : 82-32-234-6302
E-mail : fastech@fastech.co.kr Homepage : www.fastech.co.kr

- It is prohibited to copyright or replication of the part or whole of user manual without permission.
- When user manual is needed due to damage or loss, please contact head quarter of Fastech or our distributors.
- The user manual can be changed without pre-notification, in order to reflect improvement or change of the product specifications and for the improvement of user manual.
- S-SERVO is registered trademark of FASTECH Co., Ltd which is registered in Korea.

© Copyright 2013 FASTECH Co., Ltd. Jun 02, 2014 Rev.1